



REQUEST FOR PROPOSAL

**Design & Construction of a Public Safety
Communications Tower
Henniker, New Hampshire
REVISED August 7, 2023
Revised August 25, 2023**

Revision Notes: REVISED BID DUE DATE: Tuesday September 12, 10:00 am
Question and Answer added.

Introduction

The Town of Henniker invites qualified firms to submit proposals for consideration to provide professional services for the Design and Construction of a public safety communications tower on town property Craney Hill. Prospective respondents are advised to read this information over carefully prior to submitting a proposal.

Event Calendar

Proposal Due/Bid Deadline	Tuesday, September 12, 2023 @10am EST
----------------------------------	--

**Five (5) copies of the Proposal must be submitted in a sealed envelope, plainly marked:
RFP Design & Construction of Public Safety Communications Tower and delivered to:**

**ATTN: Diane Kendall
Town Administrator
Town of Henniker
18 Depot Hill Rd.
Henniker, NH 03824**

Site and pre-proposal meetings may be scheduled with the Tower Team representative.

General Requirements

Vendors making proposals must respond in writing to all requirements of this Request for Proposal (RFP). Responses should reflect detailed considerations of the issues and opportunities presented by this specific project. Any additional information or tasks that are felt to be relevant by the responding firm should be included together with the submittal requirements.

No late, email or facsimile proposals will be accepted.

Costs incurred for the preparation of a proposal in response to this RFP shall be the sole responsibility of the vendor submitting the proposal. The Town of Henniker reserves the right to select or reject any vendor that it deems to be in the best interest to accomplish the project specified. The Town reserves the right to accept the proposal on one or more items of a proposal, on all items of a proposal or any combination of items. The Town reserves the right to discontinue the selection process at any time prior to the awarding of a contract. The Town reserves the right to waive defects and informalities of the proposals.

The vendor selected may be required to execute an Agreement for Services. Vendors shall submit any exceptions to the bid specifications and / or Agreement terms.

Procurement information shall be a governmental record to the extent provided in NH RSA 91-A: 4 and RSA 91-A: 5 and shall be available to the public. Proprietary information shall be considered a governmental record. Vendors seeking to restrict public access to information contained in a response shall address concerns with the Purchasing Agent prior to submission of the response.

Project Requirements

This project is funded by a State Homeland Security Program (SHSP) Grant and bidders shall meet Contract Provisions and comply with federal laws, including the [federal procurement standards](#).

Contract Provisions 1 of 3- be sure all these are included in bids and contracts	Contract Provisions 2 of 3
<ul style="list-style-type: none">FEDERALLY-MANDATED PROCUREMENT CONTRACT PROVISIONSAll contracts awarded by <Organization> to subcontractors and involving a grant-funded Purchase of goods or services, including small purchases, must include certain federally mandated Procurement contract provisions, including:Provision CitationRecipient Termination 2 CFR Part 200 Appendix IIEqual Employment Opportunity E.O. 11246, "Equal Employment Opportunity," asamended by E.O. 11375, "Amending Executive Order11246 Relating to Equal Employment Opportunity," and as supplemented by regulations at 41 CFR part 60,"Office of Federal Contract Compliance Programs, Equal Employment Opportunity, Department of Labor."	<ul style="list-style-type: none">FEDERALLY-MANDATED PROCUREMENT CONTRACT PROVISIONSAll contracts awarded by <Organization> to subcontractors and involving a grant-funded Purchase of goods or services, including small purchases, must include certain federally mandated Procurement contract provisions, including:Provision CitationClean Air Act 42 U.S.C. 7401Federal Water Pollution Control Act 33 U.S.C. 1251Energy Efficiency 2 CFR Part 200 Appendix IICopeland "Anti-Kickback" Act 18 U.S.C. 874 and 40 U.S.C. 276CByrd Anti-Lobbying Amendment 31 U.S.C. 1352Debarment and Suspension Executive Orders 12549 and 12689Recycling 2 CFR Part 200 Appendix IIDavis-Bacon Act 40 U.S.C. 276a to a-7 see: SAM.gov Wage Determinations. MUST PAY THESE WAGE RATES. CONTRACTOR MUST TRACK THISContract Work Hours and Safety Standards Act 40 U.S.C. 327-333Rights to Inventions Made Under a Contract or Agreement37 CFR part 401 Contractor Breach Clause 2 CFR Part 200 Appendix II

Contract Provisions 3 of 3

- All contracts awarded by <Organization> to subcontractors and involving a grant-funded Purchase of goods or services, including small purchases, must also contain the following contract clauses:
- Provisions that allow for administrative, contractual, or legal remedies where contractor violates or breaches contract terms as well as remedial actions
- Provisions addressing termination by <Organization>, including manner of termination and basis for settlement
- Provisions addressing termination of contract for default as well as circumstances beyond control of subawardee
- Provisions for bid guarantees, performance bonds and payment bonds
- Provisions allowing access to subawardee records by <Organization>, federal awarding agency, Comptroller General of the United States, and any other duly authorized representative

The selected communications tower construction firm shall be expected to perform all professional services consistent with the industry accepted roles. In general, they shall include, but shall not necessarily be limited to:

- Develop a thorough familiarity with the purpose of the communications and microwave system tower to be constructed.
- Obtain any needed clearances through the Town. Including but not limited to the Public Hearings in accordance with RSA 674:54 Governmental Land Uses.
- Maintain continuous communications with the Town Administrator or designee and various sub-contractors including Radio equipment installers and vendors, as necessary.
- Provide tower design, permitting and construction services as outlined below.
- All work shall be completed following Motorola's R56 standards, **unless otherwise agreed between the vendor and the town.**

TOWER CONSTRUCTION SCOPE OF WORK

The PROJECT SCOPE consists of work at a communication tower site on the summit of Craney Hill in Henniker, NH. The project consists of the procurement and construction of a new 120-foot self-support tower, fueled backup generator system, chain link fenced compound and other general site improvements including the relocation, fit up and connection o town owned 10' x 20' equipment shelter.

The tower shall be constructed to meet the minimum tower loading for equipment currently installed on a fire tower and telephone pole existing tower at the site.

The tower should be fully equipped, including cable management, stand-off mounts and ice bridge, to accommodate the appendages listed above at the elevation and offsets shown. These systems are to be installed by the successful bidder.

The tower equipment shall include all structural hardware required to construct and install the facility per the manufacturer's specifications. The selected firm will provide the Manufacturer's product specifications electronically and descriptive documentation with at minimum elevation drawings of the proposed communications tower as an attachment to the proposal.

Work at the tower site shall include but not be limited to clearing of site, surveying and engineering of site, stamped drawings for tower and foundation, tower foundation, tower, safety cable system, required pipe (sp) clamps, pipe ends, installation materials, welding supplies, required standoff assemblies, ground bars and required ground hardware, ground wire and ground rods, installation of RF and cabling components and 10' x 20 equipment shelter, concrete generator pad, utility coordination for new service and trench utility construction per Eversource requirements.

Each site will require specific measures which shall include the following or alternative of equivalent function.

- Perimeter Security Fencing 6' high fence and one drive through gate.

Access road to the tower site will be upgraded by the Town of Henniker Highway Department, not to be included in this quote.

Information Available

The Town of Henniker is planning to upgrade its public safety communications system.

The Town of Henniker population is estimated at approximately 5,671 residents and approximately 2,287 housing units. The Town is approximately 44 square miles and is within Merrimack County. The Town of Henniker public safety communications system serves as the primary means of communication for the Henniker Police Department, Henniker Fire and Rescue Department, Henniker Highway Department, and others. Additionally, the microwave system will be used as a data backhaul for other Town services. The public safety communications system will be required to function well into the future and handle the department's anticipated growth needs.

Timeline

The tasks shall be completed by June 30, 2024.

Submittal Requirements

As part of their response to this Request for Proposals vendors shall:

- Provide information on current workload and describe how the firm would accommodate this project.
- Outline the schedule to be implemented to meet the expected project requirements and construction.
- Describe the methods the firm will use to maintain the implemented schedule.

The items listed below shall be submitted with each submission in the order shown. Each section should be clearly labeled, with pages numbered and separated by tabs. Failure by a submitter to include all listed items may result in their submission being rejected.

Tab I – Cover Letter

Provide a cover letter indicating your firm's understanding of the requirements relating to this

submission. The letter must be brief and formal from the submitter that provides information regarding the firm's interest in and ability to perform the requirements of this RFP. A person who is authorized by the organization to enter into an agreement with the Town of Henniker will sign the letter.

Please include all contact information.

Tab 2 – Acceptance of Conditions

Indicate any ~~exceptions to the agreement sample~~, specifications, terms and conditions of this RFP, including the Scope of Services.

Tab 3 – Company Background

- Years in business under present name.
- Any business name changes and the reason for the change.
- Name and address of each office location.
- Ownership structure (Corporation / Partnership).
- Names and titles of officers in the company.
- Company trade organizations / associations / affiliations.

Tab 4 – Qualifications

- Describe firm qualifications, experience and project understanding.
- Provide resumes for key personnel that will be assigned to this project.
- Demonstrate the firm's qualifications and experience in public safety communications and microwave system tower construction projects.

Tab 5 – Firm Resources

- Describe the firm's personnel resources available. If a sole proprietor, indicate so.
- Describe key personnel to be assigned from within the firm and any key outside sub-consulting firms for this project.
- Demonstration of successful management systems for the planning, organizing and monitoring of similar construction projects.
- Include a Project Team and Organization Chart of all individuals who will be assigned to work on this project. Also, list any proposed sub-consultants and their intended scope of work.

Tab 6 – References

- Provide references (with contact name and telephone number) of similar projects for which your company has, in whole or in part, provided services.

Tab 7 – List of Ongoing and Completed Projects

- Provide a list of similar projects in which your company is currently involved, or has been involved.
- Please list project description and status.
- Total dollar volume of work completed during each of the past three (3) years.

Tab 8 – Customer Support

- Describe the firm's physical availability to the Town of Henniker in terms of communication, meetings and fieldwork.

Tab 9 – Financial

- Proposed itemized cost breakdown for services as defined within this RFP for the tower.
- Performance Bonds at 100% of contract and labor/ material bonds at 100% of the contract will be required of vendor awarded the contract.
- Is your firm currently involved in, or are you anticipating, any litigation, arbitration or mediation? If so, please explain.

Tab 10 – Other

- Other information, qualifications and/or exceptions that the Inspection Services firm may consider appropriate to the selection process.

Proposals should be formatted to 8.5"x11" pages and contents bound. Submissions shall be sealed and clearly marked "RFP "Construction of Public Safety Radio and Microwave System Tower." Proposals should include but not be limited to the following information.

1. Name, address and telephone number of your firm and email of primary contact.
2. Type of organization (i.e. individual, partnership, corporation, joint venture, etc.) and year established.
3. Principles of firm.
4. Diagram of proposed organizational structure.
5. Any other information you feel is appropriate to assist in architect selection.

Costs

Submit a cost proposal as outlined in Tab 9.

Team

The vendor shall perform services as an independent contractor and shall have and maintain complete control over all of its employees, agents, and operations. Neither the vendor nor anyone employed by it shall be, represent, act, purport to act or be deemed to be the agent, representative, employee, or servant of the Town of Henniker. The vendor selected by this Request for Proposal will be working as an independent contractor and will be required to take out and keep in force all permits, licenses, certifications, other approvals, and or insurance that may be required by the Town of Henniker, any local or regional governmental agency, the State of New Hampshire, or the federal government. Failure to comply with any of these items would be grounds for immediate cancellation of the contract.

Insurance

The successful vendor will be required to submit a certificate of insurance showing minimum General Liability limits of \$1,000,000.00 per occurrence and \$2,000,000 aggregate, Professional Liability, automobile coverage and workers compensation participation. Thirty- day notice is required for cancellation of policy and Town of Henniker shall be listed as additional insured.

Licenses and Permits

All State of NH, local & federal codes, permits and licensing requirements must be met by anyone performing work on Town property. Vendor will be required to obtain permits prior to commencing any work. Local permit fees will be waived by Town. Copies of such permits and licenses will be forwarded to the Purchasing Agent for the file prior to work commencing.

Selection

- Demonstrated experience in providing service required of public safety communications projects of similar size and scope to our anticipated project.
- Quality of information based on completeness, relevance, conciseness, and organization of materials.
- Response of references.
- Have the available resources to complete the project.

The CHT Selection Group will review submissions. After reviewing submissions and prior to final ranking, the CHT Selection Group may, at its discretion, conduct interviews with a limited number of firm(s). The CHT Selection Group may, at its discretion, visit sites representing the work of a specific firm. If the Town desires to interview a firm, that firm will receive notification of the date and time of the interview. Vendors who are interviewed should anticipate interviews that focus on their approach to this project and the professionals who will be directly involved in the project.

After written submissions are received and initially evaluated, the Town may require one or more of the vendors to provide an oral presentation as a supplement to their statements. Any vendor required to interview should be prepared to discuss and substantiate any area of its submission. The Owner is under no obligation to grant interviews to any vendor receiving a copy of this RFP and/or submitting a written response to this RFP.

The CHT Selection Group' recommendation will be submitted to the Henniker Board of Selectmen for consideration. Henniker Board of Selectmen approval is required for the award of a bid and contract.

Unless otherwise stated, final payment by check will be made to Vendor within thirty (30) days of the completion of delivery of all items or service, in acceptable condition, to the Town and receipt of invoice, whichever is later. ~~Vendors that accept payment by credit card shall be paid upon the completion of delivery of all items or service, in acceptable condition, to the Town and receipt of invoice.~~

Contact Information: Signature Required

Official Entity Name		FOB Information:	
Address:			
Town, State, Zip		Availability:	
Email address:		State of Incorporation	
Warranty/guarantee:		Price holds for:	
Date:		SSN or EIN:	
Telephone #:		Fax #:	
Signature:		Title:	

BID, RFP AND QUOTE TERMS AND CONDITIONS

1. **BID ACCEPTANCE AND REJECTIONS:** The Town of Henniker reserves the right to accept any bid, and to reject any or all bids; to award the bid to other than the low bidder if deemed "bid most advantageous to the Town"; to accept the bid on one or more items of a proposal, on all items of a proposal or any combination of items of a proposal and to waive any defects in bids.
2. **FINAL BID PRICE:** Terms and FOB point are always part of the bid. FOB POINT IS ALWAYS TO BE HENNIKER, NH UNLESS OTHERWISE INDICATED BY THE BIDDER. IT IS THE BIDDER'S RESPONSIBILITY TO SO DESIGNATE A FOB POINT OTHER THAN HENNIKER. If the bidder has any special payment or delivery clauses which could affect the final delivery price of an item up for bid that too shall be made part of the bid.
3. **LATE PROPOSALS/BIDS:** Any bids received after specified date and time will not be considered, nor will late bids be opened.
4. **PAYMENT TERMS:** It is the custom of the Town of Henniker to pay its bills within 20 - 30 working days following delivery of, and receipt for, all items covered by the purchase order. In submitting bids under these specifications, bidders should take into account all discounts, both trade and time, allowed in accordance with the above payment policy.
5. **BRAND NAMES:** When the item is offered of a brand that is not known for use and/or reputation and financial stability is not well and favorably known to these officials, bids on such unknown brand may be rejected because of this lack of knowledge alone. Prospective bidders with such unknown brand should give information concerning it to the Town Purchasing Agent so that it may be checked into for bids for the coming year. The bidder will state in the proposal the brand name and any guarantees of the material he/she proposes to furnish. The brand name is to be for the material that meets all specifications.
6. **SUBCONTRACTORS:** Where a project involves utilizing subcontractors, and the project is completed satisfactorily, the Town of Henniker reserves the right to request proof of payment to subcontractors by the general contractor prior to making final payment to the general contractor.
7. **PROPER DOCUMENTATION:** Any respondent to a bid request should sign off on and return to the Purchasing Department the original Bid Documentation Package which explains the scope of the bid request. Said signature, in the spaces provided, indicates receipt of, familiarity with and understanding of, and acceptance of the specifications provided, except as otherwise noted by the respondent.
8. **BID RESULTS:** The Purchasing Office will NOT respond to phone inquiries for Bid Results, other than to identify the apparent low bidder and his total bid price quotation. Individuals or company representatives may secure a comprehensive bid analysis of a particular bid request by either attending a bid opening (which is open to all interested parties); by coming to Town Hall after a bid opening and asking to look through the file; by visiting our website at www.Henniker.org, or by sending a written request for the bid analysis along with a self-addressed stamped envelope.



RFP Question and Answer

Design & Construction of a Public Safety Communications Tower Henniker, New Hampshire August 22, 2023 Correction August 23, 2023

Permits

- Can you confirm that the General Contractor will only be applying for permits and not required to handle planning and zoning? Is the tower exempt from planning and zoning?

The tower is exempt from Planning and Zoning however the Town will prepare notice compliant with RSA 674:54, II. Written notification shall contain plans, specifications, explanations of proposed changes available at the time, a statement of the governmental nature of the use as set forth in paragraph I, and a proposed construction schedule. Such notification shall be provided at least 60 days prior to the beginning of construction. Either the governing body or planning board of the municipality may conduct a public hearing relative to the proposed governmental use. Any such hearing shall be held within 30 days after receipt of notice by the governing body or planning board. A representative of the governmental entity which provided notice shall be available to present the plans, specifications, and construction schedule, and to provide explanations. The governing body or planning board may issue nonbinding written comments relative to conformity or nonconformity of the proposal with normally applicable land use regulations to the sponsor of the governmental use within 30 days after the hearing.

Site Work Survey/Geotech

- Is the General Contractor responsible for supplying a survey and civil plan for the new site?
Yes, for the tower site. The Town will survey the access road and provide road construction.
- What will be the final size of the fenced compound, for quoting purposes?
50'x50'
- Will the General Contractor obtain the **geotechnical report**?
Yes

Power/Telecom/Fiber/Generator

- Is the General Contractor supplying the generator and transfer switch or the town?
Yes
- What type of fuel does the town want for the generator?
propane



RFP Question and Answer

Design & Construction of a Public Safety Communications Tower Henniker, New Hampshire August 22, 2023 Correction August 23, 2023

- The plans show a meter bank, but the shelter is only 200 Amp, and if nobody else is going in the compound a single meter on the building would be a cost savings.
Yes, provisions for 3 meter bank.
- Telecom, fiber and power from the site will be coming from the last pole on the site. This will require removing additional ledge and will get costly. Setting another pole or 2 poles to get closer to the site will save money. More if you can get the pole owner to set the poles and the power company to bring feeders to the last pole.
General Contractor responsible for getting power and fiber to the site in the most effective and efficient manner.
- Regarding the fiber routed from the TDS building to the utility pole then underground to the compound, will procurement of the fiber be the responsibility of the contractor or the fiber provider?
To be determined
- Regarding the Generator to be Procured, transported, and installed by the contractor? If so is there a load or brand requirement?
YES, 25kw. 1,000 gallon propane tank provided by town.
- Regarding AC needs to be supplied to the tower site, Is this from the utility pole? Are there any registration or construction fees needing to be paid by the contractor to the power company?
Yes – if primary is extended to site
- What is the current electrical load of the equipment in the fire tower, and how much capacity is to be expected?
200amp service will be sufficient.
- Will new UPS, -48v, (yes to UPS) and Alarming need to be procured by the contractor?
No
- Would the installation of these be the contractor's responsibility?
Alarm systems will be provided by town.

Shelter

- Shelter?
Pictures Attached



RFP Question and Answer

Design & Construction of a Public Safety Communications Tower Henniker, New Hampshire August 22, 2023 Correction August 23, 2023

- a. Where is the shelter presently stored? **Highway Department**
 - b. What does the “fit up” consist of? **New roof/ac/heat (mini-split); upgrade electrical as needed; new door lock**
 - c. New/ replace ac units? **New mini-split**
 - d. Roof repairs? **Yes, needs new roof**
 - e. Painting of interior and exterior? **no**
 - f. Flooring repairs? **no**
 - g. New lock set? **yes**
 - h. Cable tray in the room? **no**
 - i. Electrical upgrades? **maybe**
 - j. Room grounding halo? **No less than standard grounding**
- Would the contractor need to provide standard public safety shelter PPE and 1st Aid materials for the shelter? IE: Fire Extinguishers, Fire detection alarming, eye wash stations, and 1st Aid kits?
No

Loading for Tower:

- Is there a list of **loading** for the tower including antenna/ dish model numbers, cable sizes, and equipment heights?

The Capital Area Mutual Aid Fire Compact has two VHF antennas and two microwave dishes on the fire tower at Craney Hill. All of this equipment would need to be on the new tower.

The VHF antennas are Telewave ANT150's. Manufacturer sheet attached.

The microwave link from Craney to Wolf Hill is a Microwave Networks Proteus 18 GHz with a 2' RFS Microwave Antennas dish. The model number of either microwave dish is unknown. We think they are Compactline models. Manufacturer sheets for both of those are attached.



RFP Question and Answer

Design & Construction of a Public Safety Communications Tower Henniker, New Hampshire August 22, 2023 Correction August 23, 2023

The microwave link from Craney to Gould Hill is an Aviat Eclipse 11 GHz microwave with a 3' RFS Microwave Antennas dish. We do not have a manufacturers sheet for the Aviat link.

There is a small flat panel on the fire tower. That is a short microwave hop from the fire tower to the building that houses the highway department and Merrimack County Sheriff's Office radios. That will not be needed when we are all co-located in one building. It is there because the Police Department uses Capital Area Compact microwave network to access the site. We can do that with cables inside the new building and eliminate this link.

PD and highway have just one VHF antenna each, currently mounted on the telephone pole. The other equipment on the telephone pole and TDS building should be equipment that was abandoned by TDS telecom.

- Is the relocation of existing antennas and dishes included in the contractor's scope of work?
Yes, except cabinets housing repeaters and radio equipment which will be removed by Department communications contractors.
- Does the RFP include installing the antennas, dishes, lines, etc.?
Yes
- Will the town provide elevations for the proposed antennas on the new tower?
See attached.
- Do you want room for future growth?
Yes, no less than 20% additional loading.

Equipment

- Will new materials be provided and if so by who?
Yes, by town departments.
- If new antenna materials are being provided does the RFP include removal of existing from existing structures (fire tower)?
Yes. Roof on the fire tower shall be repaired by General Contractor after removal of existing equipment.

Prevailing Wage

- Can we get a copy of the prevailing wage rates for this project?



RFP Question and Answer

Design & Construction of a Public Safety Communications Tower Henniker, New Hampshire August 22, 2023 Correction August 23, 2023

Contractor is responsible to identify the Wage Determination from [Link to Sam.gov Wage Determination](#) and see attached for Building and Heavy Construction Types.

Deadlines:

- Will the Town extend the Proposal Due deadline?
The town will consider a deadline extension if requested.
- Will supply chain issues be a consideration if job runs over the proposed finished date?
No, the grant funds expire August 31, 2024. The project must be completed by June 30, 2024 and all billed items shall be submitted by the town to the granting agency for reimbursement by July 30, 2024.

Payment Terms

- What payment terms, retention amounts, and invoicing milestones will apply?
Milestone invoicing to be proposed by vendor; 30 day payment terms; 10% retention to completion.

Warranty/Bond

- Is a bid bond or check required with the bid?
Bid bond is not required. Performance bond required at acceptance of contract.
- What is the warranty / guarantee?
1 year install and 5 year tower.
- Can you tell us more about the Labor and Materials bond required?
The general contractor, or the principal, promises to pay the stakeholders who contribute to the project. If they fail to fulfill this promise, the surety will pay damages to these stakeholders in their place.

Testing, reporting,

- What special system testing, inspection, or documentation is required during or after construction?
Unknown, to be proposed by vendor.
- Any specific ground tests required at completion of job?
Unknown, to be proposed by vendor.



RFP Question and Answer

Design & Construction of a Public Safety Communications Tower Henniker, New Hampshire August 22, 2023 Correction August 23, 2023

RFP Presentation

- Will you require RFP responses to be professionally bound or is a three-ring binder acceptable?
Professional binding is not required

Section 106

- Will Section 106 Architectural Review and 620/621 Form Submission to SHPO and FCC be required? Will an Archaeology Review be required? Will a Public Notice in the local paper be a requirement?
Section 106 has been submitted. See attached. Town is waiting for final approval.
- Will a viewshed report be required by the town?
No

Other conditions:

Federal Grant Provisions (Code of Federal Regulations 2 C.F.R. 200) this grant is funded with Federal Grant Funds. Potential “bidders” should have clear sight of the Federal Grant conditions for compliance. (sample but not all inclusive below).

Contract Provisions 1 of 3- be sure all these are included in bids and contracts

- **FEDERALLY-MANDATED PROCUREMENT CONTRACT PROVISIONS**
- All contracts awarded by <Organization> to subcontractors and involving a grant-funded Purchase of goods or services, including small purchases, must include certain federally mandated Procurement contract provisions, including:
- **Provision Citation**
- Recipient Termination 2 CFR Part 200 Appendix II
- Equal Employment Opportunity E.O. 11246, "Equal Employment Opportunity," as amended by E.O. 11375, "Amending Executive Order 11246 Relating to Equal Employment Opportunity," and as supplemented by regulations at 41 CFR part 60,
- "Office of Federal Contract Compliance Programs, Equal Employment Opportunity, Department of Labor."

Contract Provisions 2 of 3

- **FEDERALLY-MANDATED PROCUREMENT CONTRACT PROVISIONS**
- All contracts awarded by <Organization> to subcontractors and involving a grant-funded Purchase of goods or services, including small purchases, must include certain federally mandated Procurement contract provisions, including:
- **Provision Citation**
- Clean Air Act 42 U.S.C. 7401
- Federal Water Pollution Control Act 33 U.S.C. 1251
- Energy Efficiency 2 CFR Part 200 Appendix II
- Copeland "Anti-Kickback" Act 18 U.S.C. 874 and 40 U.S.C. 276C
- Byrd Anti-Lobbying Amendment 31 U.S.C. 1352
- Debarment and Suspension Executive Orders 12549 and 12689
- Recycling 2 CFR Part 200 Appendix II
- **Davis-Bacon Act 40 U.S.C. 276a to a-7 see: [SAM.gov | Wage Determinations](#). MUST PAY THESE WAGE RATES. CONTRACTOR MUST TRACK THIS**
- Contract Work Hours and Safety Standards Act 40 U.S.C. 327-333
- Rights to Inventions Made Under a Contract or Agreement
- 37 CFR part 401 Contractor Breach Clause 2 CFR Part 200 Appendix II



RFP Question and Answer

Design & Construction of a Public Safety Communications Tower Henniker, New Hampshire August 22, 2023 Correction August 23, 2023

Contract Provisions 3 of 3

- All contracts awarded by <Organization> to subcontractors and involving a grant-funded Purchase of goods or services, including small purchases, must also contain the following contract clauses:
- Provisions that allow for administrative, contractual, or legal remedies where contractor violates or breaches contract terms as well as remedial actions
- Provisions addressing termination by <Organization>, including manner of termination and basis for settlement
- Provisions addressing termination of contract for default as well as circumstances beyond control of subawardee
- Provisions for bid guarantees, performance bonds and payment bonds
- Provisions allowing access to subawardee records by <Organization>, federal awarding agency, Comptroller General of the United States, and any other duly authorized representative

- **Equipment:** *The subrecipient agrees that, when practicable, any equipment purchased with grant funding shall be prominently marked as follows: "Purchased with funds provided by the U.S. Department of Homeland Security and the NH Department of Safety - Grants Management Bureau." Additionally, when practicable, any equipment purchased with funding under this agreement shall bear on it the logos of the NH Department of Safety - Grants Management Bureau and U.S. Department of Homeland Security.*
- *All projects must be competed at least 30 days prior to end of the grant period as specified on the Grant Special Conditions page. No work may be completed or be eligible for reimbursement if it occurs after the grant period end date.*
- *All sub-grantees must comply with the National Incident Management System (NIMS) minimum requirements as specified in the Fiscal Year 2021 Homeland Security Grant Program Guidelines. Additional information about achieving compliance is available through the training officers at the NH Department of Safety's Fire Academy and EMS Bureau and the Division of Homeland Security and Emergency Management.*







A white terminal block with nine black terminals arranged in a 3x3 grid, mounted on the side of the shed.

A large, tan-colored metal electrical enclosure with a fan and ventilation grilles, mounted on the side of the shed. It has a small label on the top right that reads "Low Voltage".

A white, dome-shaped outdoor light fixture mounted on a post to the right of the shed.

ANT150F2 FIBERGLASS COLLINEAR ANTENNA 2.5 dBd

The Telewave ANT150F2 is an extremely rugged collinear antenna, with moderate gain and wide vertical beamwidth. This compact antenna produces 2.5 dBd gain, and is designed for operation in all environmental conditions. The antenna is constructed with brass and copper elements, with a path to DC ground for lightning impulse protection.

All junctions are fully soldered to prevent RF intermodulation, and each antenna is completely protected within a rugged, high-tech radome to ensure survivability in the worst environments. The "Cool Blue" radome provides maximum protection from corrosive gases, ultraviolet radiation, icing, salt spray, acid rain, and wind blown abrasives.

The ANT150F2 includes the ANTC485 dual clamp set for mounting to a 1.5" to 3" O.D. support pipe, and a 24" removable RG-213 N-Male jumper.

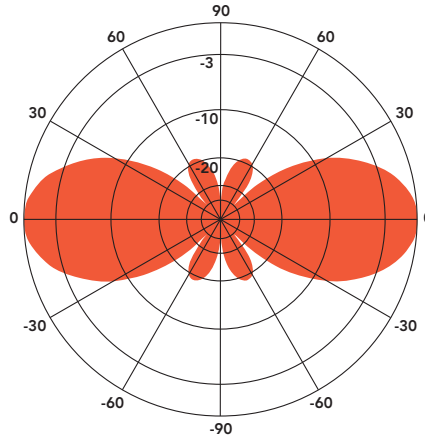

ANT150F2 156 MHz
Vertical Plane
Gain = 2.55 dBd

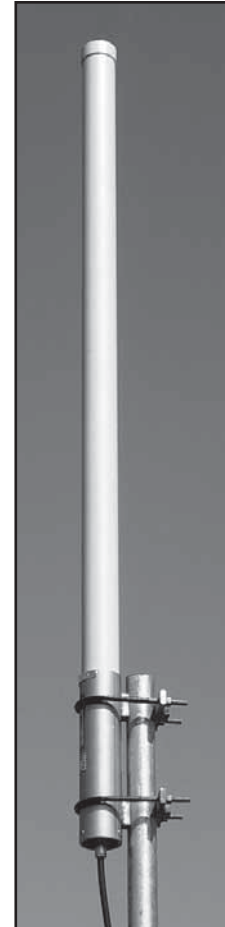
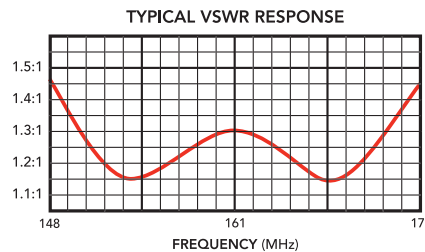

SPECIFICATIONS			
Frequency (continuous)	148-174 MHz	Dimensions (L x base diam.) in.	60 x 2.75
Gain	2.5 dBd	Tower weight (antenna + clamps)	12 lb.
Power rating (typ.)	500 watts	Shipping weight	16 lb.
Impedance	50 ohms	Wind rating / with 0.5" ice	200 / 150 MPH
VSWR	1.5:1 or less	Maximum exposed area	1.3 ft. ²
Pattern	Omnidirectional	Lateral thrust at 100 MPH	50 lb.
Vertical beamwidth	38°	Bending moment at top clamp	67 ft. lb.
Termination	Recessed N Female 7-16 DIN-F opt.	(100 MPH, 40 PSF flat plate equiv.)	



**ATTN: Diane Kendall
Town Administrator
Town Of Henniker**

**RE: RFP Design & Construction of a Public Safety Communications Tower
Questions & Clarifications**

The following is a list of clarifications for the Henniker project which will greatly assist us in providing an all-inclusive bid for this project.

- Will Section 106 Architectural Review and 620/621 Form Submission to SHPO and FCC be required?
- Will an Archaeology Review be required?
- Will a Public Notice in the local paper be a requirement?
- Is NEPA and a Phase 1 required?
- Will a viewshed report be required by the town?
- Will the town provide elevations for the proposed antennas on the new tower?
- Will any future tower loading be required and if so, will the town provide?
- Does the town have generator specs?
- Any specific ground test required at completion of job?
- Will the site require a new service and if so what size?
- Will supply chain issues be a consideration if job runs over the proposed finished date?
- Can you provide us the prevailing wage rates?
- Can you tell us more about the Labor and Materials bond required?
- Will you require RFP responses to be professionally bound or is a three-ring binder acceptable?

If you have any questions or concerns, please give me a call at 603.234.6403 or by email d.sykes@greenmtncomm.com.

Submitted by:

GREEN MOUNTAIN COMMUNICATIONS, INC.

A handwritten signature in black ink, appearing to read "D Sykes", is placed over a light gray rectangular background.

Dave Sykes, Sr Project Manager



Proteus OIP

ANSI



All Outdoor IP Licensed Microwave Radio

6 to 38 GHz (licensed bands)

36 to 313 Mbps

Proteus OIP is Microwave Networks' complete outdoor Ethernet transport solution for networks with stringent zero footprint requirements. It is ideal for use in emerging 4G / LTE networks as well as in traditional Cellular, Enterprise, Utility, Railroad, and Public Safety systems.

By eliminating the need for rack space in shelters or enclosures, Proteus OIP offers the perfect solution for low impact installation while still providing carrier-grade service and reliability as well as a rapid ROI.

- **Frequencies:** 6, 7, 8, 11, 15, 18, 23, 26 & 38 GHz
- **Data Rates:** Up to 313 Mbps in 50 MHz
- **Configurations:** All Outdoor 1+0
- **Features:** Hitless Adaptive Code and Modulation
 - Automatic Transmit Power Control
 - RJ45 Gigabit Ethernet
 - Jumbo Frames to 9600 bytes



System Specifications

Frequency Bands	6, 7, 8, 11, 15, 18, 23, 26 and 38 GHz
Modulation Formats	QPSK, 16 QAM, 32 QAM, 64 QAM, 128 QAM, 256 QAM
Configuration	1+0
System Gain Enhancements	ACM, ATPC, FEC
Frequency Stability	±7 ppm
Frequency Resolution	250 kHz
Regulatory Compliance	Radio: FCC Part 101; EMI/EMC; ETSI EN 301-489-1/-4, Safety: EN 60950-1/-22; Radiation Safety: ETSI EN 50385
Mean Time Between Failures	>30 years

Payload Parameters

Payload Type/Format	Ethernet, VLAN
Payload Latency	<200 µsec/64 byte packets, <300µsec/1518 byte packets
QoS, VLAN, Q-in-Q	IEEE 802.1p, IEEE 802.1Q
Jumbo Frame	Up to 9600 bytes

Interfaces

Payload Interface	Electrical: 10/100/1000 Base-T – RJ45 w/ Power Over Ethernet
Management Interface:	10/100 BaseT – RJ45 w/ Power Over Ethernet
Antenna Interface	Push-fit direct mount
AGC voltage (RSSI)	BNC
Ground	M5 Screw Lug

Power

Voltage	-30 to -60 VDC
Power Consumption	80W maximum
Power Delivery	Power Over Ethernet delivered on Data and/or management cable
Power over Ethernet Unit	Indoor/outdoor mountable DC power injector installed in-line with data or network cable, or both.
Power Connector (on Power Over Ethernet)	3-pin screw plug on Power Over Ethernet Unit

Mechanical & Environmental

Outdoor Unit Dimensions, mm (D x H)	267 (diameter) x 140 (height)
Outdoor Unit Weight (kg)	<6
Outdoor Unit Temperature Range	-33°C to +55°C, full specifications
PoE Unit Dimensions, mm (L x W x D)	170 x 150 x 39
PoE Unit Weight (kg)	0.5
PoE Unit Temperature Range	-33°C to +55°C, full specifications



Date: 8/15/2023
New Site : Town of Henniker, NH
Address: Tower Rd. / Lester Lane
Coordinates: LAT: 43.15068
LON: 71.79817

Tower: 120' Class 3 Public safety tower for critical infrastructure

- Monopoles: Design with a 70% tower rating
Largest entry port size possible and extras
Minimum diameter at top shall be 18"
All towers unless specifically called out otherwise will have climbing pegs
All safety climbs shall be stainless steel
- Guyed Towers: Design with a 70% tower rating
All should have a face width of 60"
All safety climbs shall be stainless steel
- Self supporters: Design with future expansion as listed
Safety climbs shall be stainless steel
Include tower lightning rod
Include cable ladder to top
Do not include grounding materials

120' (2) ANT150F2 antennas,

118'+- CL (1) 2' 18GHz Microwave Networks Proteus radio with 2' RFS Dish (figure worst case. See attached email pic). Small elliptical cable
(1) 3' 11 GHz Aviat Eclipse radio with 3' RFS Dish (figure worst case for type f dish not sure if cover is soft or hard dome. See attached email pic). Small elliptical cable

100'+- (1) 20'+- whip antenna 3-4'+- dia. 7/8" coax
(1) 6-8'+- whip antenna 1-2'+- dia. 1/2" coax
F (1) 4' Dish

F 90' (3) 10'+- whip antennas
(1) 4' Dish

F 80' (3) 10'+- whip antennas

F- Future carrier on future extension
CL- Center line

SPECIAL NOTES:

"General Decision Number: NH20230019 07/14/2023

Superseded General Decision Number: NH20220019

State: New Hampshire

Construction Type: Building

County: Merrimack County in New Hampshire.

BUILDING CONSTRUCTION PROJECTS (does not include single family homes or apartments up to and including 4 stories).

Note: Contracts subject to the Davis-Bacon Act are generally required to pay at least the applicable minimum wage rate required under Executive Order 14026 or Executive Order 13658.

Please note that these Executive Orders apply to covered contracts entered into by the federal government that are subject to the Davis-Bacon Act itself, but do not apply to contracts subject only to the Davis-Bacon Related Acts, including those set forth at 29 CFR 5.1(a)(2)-(60).

If the contract is entered into on or after January 30, 2022, or the contract is renewed or extended (e.g., an option is exercised) on or after January 30, 2022:	. Executive Order 14026 generally applies to the contract. The contractor must pay all covered workers at least \$16.20 per hour (or the applicable wage rate listed on this wage determination, if it is higher) for all hours spent performing on the contract in 2023.
---	---

If the contract was awarded on or between January 1, 2015 and January 29, 2022, and the contract is not renewed or extended on or after January 30, 2022:	. Executive Order 13658 generally applies to the contract. The contractor must pay all covered workers at least \$12.15 per hour (or the applicable wage rate listed on this wage determination, if it is higher) for all hours spent performing on that contract in 2023.
---	--

The applicable Executive Order minimum wage rate will be adjusted annually. If this contract is covered by one of the Executive Orders and a classification considered necessary for performance of work on the contract does not appear on this

wage determination, the contractor must still submit a conformance request.

Additional information on contractor requirements and worker protections under the Executive Orders is available at <http://www.dol.gov/whd/govcontracts>.

Modification Number	Publication Date
0	01/06/2023
1	01/13/2023
2	02/10/2023
3	02/24/2023
4	04/07/2023
5	07/14/2023

ASBE0006-014 09/01/2022

Rates Fringes

ASBESTOS WORKER/HEAT & FROST
INSULATOR.....\$ 41.00 33.99

ELEC0490-002 01/01/2023

Rates Fringes

ELECTRICIAN.....\$ 33.30 22.05

IRON0007-040 03/16/2023

Rates Fringes

IRONWORKER, STRUCTURAL.....\$ 30.08 24.72

* LABO0668-001 06/01/2023

Rates Fringes

LABORER: Common or General.....\$ 25.36 20.82

* PLUM0131-003 06/05/2023

Rates Fringes

PIPEFITTER.....\$ 40.36 25.24

SUNH2015-005 06/16/2017

Rates Fringes

Carpenter, Includes Drywall
Finishing/Taping, Drywall
Hanging and Metal Stud

Installation.....	\$ 26.19	9.06
CEMENT MASON/CONCRETE FINISHER...	\$ 23.55	7.14
IRONWORKER, REINFORCING.....	\$ 29.89	10.70
LABORER: Mason Tender - Brick...	\$ 19.60	2.73
LABORER: Mason Tender - Cement/Concrete.....	\$ 20.85	2.61
OPERATOR: Backhoe/Excavator/Trackhoe.....	\$ 21.52	3.17
PAINTER (Brush and Roller).....	\$ 20.62	0.00
PLUMBER.....	\$ 25.24	8.60
ROOFER.....	\$ 18.87	0.00
SHEET METAL WORKER, Includes HVAC Duct Installation.....	\$ 26.56	24.03
TRUCK DRIVER: Dump Truck.....	\$ 17.43	3.60

WELDERS - Receive rate prescribed for craft performing operation to which welding is incidental.

=====

Note: Executive Order (EO) 13706, Establishing Paid Sick Leave for Federal Contractors applies to all contracts subject to the Davis-Bacon Act for which the contract is awarded (and any solicitation was issued) on or after January 1, 2017. If this contract is covered by the EO, the contractor must provide employees with 1 hour of paid sick leave for every 30 hours they work, up to 56 hours of paid sick leave each year. Employees must be permitted to use paid sick leave for their own illness, injury or other health-related needs, including preventive care; to assist a family member (or person who is like family to the employee) who is ill, injured, or has other health-related needs, including preventive care; or for reasons resulting from, or to assist a family member (or person who is like family to the employee) who is a victim of, domestic violence, sexual assault, or stalking. Additional information on contractor requirements and worker protections under the EO is available at <https://www.dol.gov/agencies/whd/government-contracts>.

Unlisted classifications needed for work not included within the scope of the classifications listed may be added after award only as provided in the labor standards contract clauses (29CFR 5.5 (a) (1) (ii)).

The body of each wage determination lists the classification and wage rates that have been found to be prevailing for the cited type(s) of construction in the area covered by the wage determination. The classifications are listed in alphabetical order of ""identifiers"" that indicate whether the particular rate is a union rate (current union negotiated rate for local), a survey rate (weighted average rate) or a union average rate (weighted union average rate).

Union Rate Identifiers

A four letter classification abbreviation identifier enclosed in dotted lines beginning with characters other than ""SU"" or ""UAVG"" denotes that the union classification and rate were prevailing for that classification in the survey. Example: PLUM0198-005 07/01/2014. PLUM is an abbreviation identifier of the union which prevailed in the survey for this classification, which in this example would be Plumbers. 0198 indicates the local union number or district council number where applicable, i.e., Plumbers Local 0198. The next number, 005 in the example, is an internal number used in processing the wage determination. 07/01/2014 is the effective date of the most current negotiated rate, which in this example is July 1, 2014.

Union prevailing wage rates are updated to reflect all rate changes in the collective bargaining agreement (CBA) governing this classification and rate.

Survey Rate Identifiers

Classifications listed under the ""SU"" identifier indicate that no one rate prevailed for this classification in the survey and the published rate is derived by computing a weighted average rate based on all the rates reported in the survey for that classification. As this weighted average rate includes all rates reported in the survey, it may include both union and non-union rates. Example: SULA2012-007 5/13/2014. SU indicates the rates are survey rates based on a weighted average calculation of rates and are not majority rates. LA indicates the State of Louisiana. 2012 is the year of survey on which these classifications and rates are based. The next number, 007 in the example, is an internal number used in producing the wage determination. 5/13/2014 indicates the survey completion date for the classifications and rates under that identifier.

Survey wage rates are not updated and remain in effect until a new survey is conducted.

Union Average Rate Identifiers

Classification(s) listed under the UAVG identifier indicate that no single majority rate prevailed for those classifications; however, 100% of the data reported for the classifications was union data. EXAMPLE: UAVG-OH-0010 08/29/2014. UAVG indicates that the rate is a weighted union average rate. OH indicates the state. The next number, 0010 in the example, is an internal number used in producing the wage determination. 08/29/2014 indicates the survey completion date for the classifications and rates under that identifier.

A UAVG rate will be updated once a year, usually in January of each year, to reflect a weighted average of the current negotiated/CBA rate of the union locals from which the rate is based.

WAGE DETERMINATION APPEALS PROCESS

1.) Has there been an initial decision in the matter? This can be:

- * an existing published wage determination
- * a survey underlying a wage determination
- * a Wage and Hour Division letter setting forth a position on a wage determination matter
- * a conformance (additional classification and rate) ruling

On survey related matters, initial contact, including requests for summaries of surveys, should be with the Wage and Hour National Office because National Office has responsibility for the Davis-Bacon survey program. If the response from this initial contact is not satisfactory, then the process described in 2.) and 3.) should be followed.

With regard to any other matter not yet ripe for the formal process described here, initial contact should be with the Branch of Construction Wage Determinations. Write to:

Branch of Construction Wage Determinations
Wage and Hour Division
U.S. Department of Labor
200 Constitution Avenue, N.W.
Washington, DC 20210

2.) If the answer to the question in 1.) is yes, then an interested party (those affected by the action) can request review and reconsideration from the Wage and Hour Administrator (See 29 CFR Part 1.8 and 29 CFR Part 7). Write to:

Wage and Hour Administrator
U.S. Department of Labor
200 Constitution Avenue, N.W.
Washington, DC 20210

The request should be accompanied by a full statement of the interested party's position and by any information (wage payment data, project description, area practice material, etc.) that the requestor considers relevant to the issue.

3.) If the decision of the Administrator is not favorable, an interested party may appeal directly to the Administrative Review Board (formerly the Wage Appeals Board). Write to:

Administrative Review Board
U.S. Department of Labor
200 Constitution Avenue, N.W.
Washington, DC 20210

4.) All decisions by the Administrative Review Board are final.

=====

END OF GENERAL DECISIO"

"General Decision Number: NH20230030 01/06/2023

Superseded General Decision Number: NH20220030

State: New Hampshire

Construction Type: Heavy

Counties: Belknap and Merrimack Counties in New Hampshire.

HEAVY CONSTRUCTION PROJECTS

Note: Contracts subject to the Davis-Bacon Act are generally required to pay at least the applicable minimum wage rate required under Executive Order 14026 or Executive Order 13658. Please note that these Executive Orders apply to covered contracts entered into by the federal government that are subject to the Davis-Bacon Act itself, but do not apply to contracts subject only to the Davis-Bacon Related Acts, including those set forth at 29 CFR 5.1(a)(2)-(60).

If the contract is entered into on or after January 30, 2022, or the contract is renewed or extended (e.g., an option is exercised) on or after January 30, 2022:	Executive Order 14026 generally applies to the contract. The contractor must pay all covered workers at least \$16.20 per hour (or the applicable wage rate listed on this wage determination, if it is higher) for all hours spent performing on the contract in 2023.
---	---

If the contract was awarded on or between January 1, 2015 and January 29, 2022, and the contract is not renewed or extended on or after January 30, 2022:	Executive Order 13658 generally applies to the contract. The contractor must pay all covered workers at least \$12.15 per hour (or the applicable wage rate listed on this wage determination, if it is higher) for all hours spent performing on that contract in 2023.
---	--

The applicable Executive Order minimum wage rate will be adjusted annually. If this contract is covered by one of the Executive Orders and a classification considered necessary for performance of work on the contract does not appear on this

wage determination, the contractor must still submit a conformance request.

Additional information on contractor requirements and worker protections under the Executive Orders is available at <http://www.dol.gov/whd/govcontracts>.

Modification Number Publication Date
0 01/06/2023

SUNH2015-016 06/16/2017

	Rates	Fringes
CARPENTER, Includes Form Work....	\$ 22.50	3.32
CEMENT MASON/CONCRETE FINISHER...	\$ 16.00 **	3.04
IRONWORKER, REINFORCING.....	\$ 22.02	0.00
LABORER: Common or General.....	\$ 17.84	7.69
LABORER: Pipelayer.....	\$ 18.81	2.82
OPERATOR: Backhoe/Excavator/Trackhoe.....	\$ 24.31	5.65
OPERATOR: Drill.....	\$ 21.00	9.10
OPERATOR: Loader.....	\$ 19.00	2.53
TRUCK DRIVER: Dump Truck.....	\$ 16.89	1.66

WELDERS - Receive rate prescribed for craft performing operation to which welding is incidental.

** Workers in this classification may be entitled to a higher minimum wage under Executive Order 14026 (\$16.20) or 13658 (\$12.15). Please see the Note at the top of the wage determination for more information.

Note: Executive Order (EO) 13706, Establishing Paid Sick Leave for Federal Contractors applies to all contracts subject to the Davis-Bacon Act for which the contract is awarded (and any solicitation was issued) on or after January 1, 2017. If this contract is covered by the EO, the contractor must provide employees with 1 hour of paid sick leave for every 30 hours they work, up to 56 hours of paid sick leave each year. Employees must be permitted to use paid sick leave for their own illness, injury or other health-related needs, including

preventive care; to assist a family member (or person who is like family to the employee) who is ill, injured, or has other health-related needs, including preventive care; or for reasons resulting from, or to assist a family member (or person who is like family to the employee) who is a victim of, domestic violence, sexual assault, or stalking. Additional information on contractor requirements and worker protections under the EO is available at <https://www.dol.gov/agencies/whd/government-contracts>.

Unlisted classifications needed for work not included within the scope of the classifications listed may be added after award only as provided in the labor standards contract clauses (29CFR 5.5 (a) (1) (ii)).

The body of each wage determination lists the classification and wage rates that have been found to be prevailing for the cited type(s) of construction in the area covered by the wage determination. The classifications are listed in alphabetical order of ""identifiers"" that indicate whether the particular rate is a union rate (current union negotiated rate for local), a survey rate (weighted average rate) or a union average rate (weighted union average rate).

Union Rate Identifiers

A four letter classification abbreviation identifier enclosed in dotted lines beginning with characters other than ""SU"" or ""UAVG"" denotes that the union classification and rate were prevailing for that classification in the survey. Example: PLUM0198-005 07/01/2014. PLUM is an abbreviation identifier of the union which prevailed in the survey for this classification, which in this example would be Plumbers. 0198 indicates the local union number or district council number where applicable, i.e., Plumbers Local 0198. The next number, 005 in the example, is an internal number used in processing the wage determination. 07/01/2014 is the effective date of the most current negotiated rate, which in this example is July 1, 2014.

Union prevailing wage rates are updated to reflect all rate changes in the collective bargaining agreement (CBA) governing this classification and rate.

Survey Rate Identifiers

Classifications listed under the ""SU"" identifier indicate that no one rate prevailed for this classification in the survey and the published rate is derived by computing a weighted average rate based on all the rates reported in the survey for that

classification. As this weighted average rate includes all rates reported in the survey, it may include both union and non-union rates. Example: SULA2012-007 5/13/2014. SU indicates the rates are survey rates based on a weighted average calculation of rates and are not majority rates. LA indicates the State of Louisiana. 2012 is the year of survey on which these classifications and rates are based. The next number, 007 in the example, is an internal number used in producing the wage determination. 5/13/2014 indicates the survey completion date for the classifications and rates under that identifier.

Survey wage rates are not updated and remain in effect until a new survey is conducted.

Union Average Rate Identifiers

Classification(s) listed under the UAVG identifier indicate that no single majority rate prevailed for those classifications; however, 100% of the data reported for the classifications was union data. EXAMPLE: UAVG-OH-0010 08/29/2014. UAVG indicates that the rate is a weighted union average rate. OH indicates the state. The next number, 0010 in the example, is an internal number used in producing the wage determination. 08/29/2014 indicates the survey completion date for the classifications and rates under that identifier.

A UAVG rate will be updated once a year, usually in January of each year, to reflect a weighted average of the current negotiated/CBA rate of the union locals from which the rate is based.

WAGE DETERMINATION APPEALS PROCESS

1.) Has there been an initial decision in the matter? This can be:

- * an existing published wage determination
- * a survey underlying a wage determination
- * a Wage and Hour Division letter setting forth a position on a wage determination matter
- * a conformance (additional classification and rate) ruling

On survey related matters, initial contact, including requests for summaries of surveys, should be with the Wage and Hour National Office because National Office has responsibility for the Davis-Bacon survey program. If the response from this initial contact is not satisfactory, then the process described in 2.) and 3.) should be followed.

With regard to any other matter not yet ripe for the formal

process described here, initial contact should be with the Branch of Construction Wage Determinations. Write to:

Branch of Construction Wage Determinations
Wage and Hour Division
U.S. Department of Labor
200 Constitution Avenue, N.W.
Washington, DC 20210

2.) If the answer to the question in 1.) is yes, then an interested party (those affected by the action) can request review and reconsideration from the Wage and Hour Administrator (See 29 CFR Part 1.8 and 29 CFR Part 7). Write to:

Wage and Hour Administrator
U.S. Department of Labor
200 Constitution Avenue, N.W.
Washington, DC 20210

The request should be accompanied by a full statement of the interested party's position and by any information (wage payment data, project description, area practice material, etc.) that the requestor considers relevant to the issue.

3.) If the decision of the Administrator is not favorable, an interested party may appeal directly to the Administrative Review Board (formerly the Wage Appeals Board). Write to:

Administrative Review Board
U.S. Department of Labor
200 Constitution Avenue, N.W.
Washington, DC 20210

4.) All decisions by the Administrative Review Board are final.

END OF GENERAL DECISIO"

Please mail the completed form and required material to:

New Hampshire Division of Historical Resources
State Historic Preservation Office
Attention: Review & Compliance
19 Pillsbury Street, Concord, NH 03301-3570

DHR Use Only	
R&C #	_____
Log In Date	___ / ___ / ___
Response Date	___ / ___ / ___
Sent Date	___ / ___ / ___

Request for Project Review by the New Hampshire Division of Historical Resources

- This is a new submittal
 This is additional information relating to DHR Review & Compliance (R&C) #:

GENERAL PROJECT INFORMATION

Project Title Craney Hill Telecommunications Tower

Project Location Craney Hill

City/Town Henniker Tax Map 654 Lot # A

NH State Plane - Feet Geographic Coordinates: Easting 949188 Northing 237296
(See RPR Instructions and R&C FAQs for guidance.)

Lead Federal Agency and Contact *(if applicable)* FCC
(Agency providing funds, licenses, or permits)
 Permit Type and Permit or Job Reference #

State Agency and Contact *(if applicable)*
 Permit Type and Permit or Job Reference #

APPLICANT INFORMATION

Applicant Name Town of Henniker

Mailing Address 18 Depot Hill Road Phone Number 603-428-3221

City Henniker State NH Zip 03242 Email diane.kendall@henniker.org

CONTACT PERSON TO RECEIVE RESPONSE

Name/Company Audra Klumb, A&D Klumb Environmental, LLC

Mailing Address 34 Centennial Drive Phone Number 6037465065

City Webster State NH Zip 03303 Email ADKE@klumbenv.com

*This form is updated periodically. Please download the current form at www.nh.gov/nhdhr/review. Please refer to the Request for Project Review Instructions for direction on completing this form. Submit one copy of this project review form for each project for which review is requested. **Please include a self-addressed stamped envelope.** Project submissions will not be accepted via facsimile or e-mail. This form is required. Review request form must be complete for review to begin. Incomplete forms will be sent back to the applicant without comment. Please be aware that this form may only initiate consultation. For some projects, additional information will be needed to complete the Section 106 review. All items and supporting documentation submitted with a review request, including photographs and publications, will be retained by the DHR as part of its review records. Items to be kept confidential should be clearly identified. For questions regarding the DHR review process and the DHR's role in it, please visit our website at: www.nh.gov/nhdhr/review or contact the R&C Specialist at marika.s.labash@dncr.nh.gov or 603.271.3558.*

PROJECTS CANNOT BE PROCESSED WITHOUT THIS INFORMATION

Project Boundaries and Description

- Attach the Project Mapping **using EMMIT or relevant portion of a 7.5' USGS Map.** (See RPR Instructions and R&C FAQs for guidance.)
- Attach a detailed narrative description of the proposed project.
- Attach a site plan. The site plan should include the project boundaries and areas of proposed excavation.
- Attach photos of the project area (overview of project location and area adjacent to project location, and specific areas of proposed impacts and disturbances.) (Informative photo captions are requested.)
- A DHR records search must be conducted to identify properties within or adjacent to the project area. Provide records search results via EMMIT or in **Table 1.** (Blank table forms are available on the DHR website.) Please note, using EMMIT Guest View for an RPR records search does not provide the necessary information needed for DHR review.
EMMIT or in-house records search conducted on 1/19/2023.

Architecture

Are there any buildings, structures (bridges, walls, culverts, etc.) objects, districts or landscapes within the project area? Yes No
If no, skip to Archaeology section. If yes, submit all of the following information:

Approximate age(s): 84

- Photographs of **each** resource or streetscape located within the project area, with captions, along with a mapped photo key. (Digital photographs are accepted. All photographs must be clear, crisp and focused.)
- If the project involves rehabilitation, demolition, additions, or alterations to existing buildings or structures, provide additional photographs showing detailed project work locations. (i.e. Detail photo of windows if window replacement is proposed.)

Archaeology

Does the proposed undertaking involve ground-disturbing activity? Yes No
If yes, submit all of the following information:

- Description of current and previous land use and disturbances.
- Available information concerning known or suspected archaeological resources within the project area (such as cellar holes, wells, foundations, dams, etc.)

Please note that for many projects an architectural and/or archaeological survey or other additional information may be needed to complete the Section 106 process.

DHR Comment/Finding Recommendation *This Space for Division of Historical Resources Use Only*

- Insufficient information to initiate review.** Additional information is needed in order to complete review.
- No Potential to cause Effects No Historic Properties Affected No Adverse Effect Adverse Effect

Comments: _____

If plans change or resources are discovered in the course of this project, you must contact the Division of Historical Resources as required by federal law and regulation.

Authorized Signature: _____ Date: _____



A&D Klumb Environmental, LLC

April 17, 2023

NH Division of Historical Resources
Attention: Review & Compliance
19 Pillsbury Street
Concord, NH 03301

RE: Section 106 Review, Proposed Tower Facility, Craney Hill, Henniker, NH
FCC Form 620

Dear NH DHR Review & Compliance:

A&D Klumb Environmental, LLC has completed an architectural and archaeological survey of National Register listed and eligible historic resources in compliance with Section 106 for a proposed telecommunication facility to be located on the summit of Craney Hill in Henniker, Merrimack County, NH. The Town of Henniker proposes to construct a 120-foot tall lattice tower within a fenced compound on the summit of Craney Hill, accessed by the existing woods road from Craney Hill Road.

The purpose of this investigation is to identify any historic properties within the Area of Potential Effect (APE) of the installation and to determine any adverse impacts on those historic structures. This project is required by the New Hampshire Division of Historical Resources and the FCC for Section 106 review of the facility.

The objectives of the project were fulfilled through background research, reconnaissance at and within the vicinity of the project area to identify standing resources and cultural landscapes potentially possessing qualities of significance necessary for listing in the National Register, and assessment of potential effects found in Section 800 of the National Historic Preservation Act of 1966, as amended. The direct APE is defined as the proposed area of disturbance for the site's construction. The indirect (visual) APE is defined as the area within a ½ mile radius from the proposed project. The visual APE was surveyed on February 21, 2023. The direct APE was surveyed on April 10, 2023.

Project Description

The proposed tower site is to be located within a forested area on the summit of Craney Hill. The tower will be located approximately 75-feet northeast of the existing fire tower. The access will follow the existing woods road, identified as Lester Lane on the project drawing. The utilities will lead from the existing TDS building overhead to the existing utility pole and then underground to the site.

Historic Properties

The NH DHR file review for National Register listed and eligible properties and districts was completed online through EMMIT on January 19, 2023 and check on April 17, 2023. The file review found no National Register listed or eligible properties within the ½ mile APE.

ADKE reviewed the project for visual impacts to historic properties on February 21, 2023. Public roads within the ½ mile APE were walked or driven to identify properties and resources potentially eligible for the National Register and to determine the visibility of the proposed tower within the vicinity of these resources. The ½-mile APE includes Craney Hill Road and Tower Road. One property within the APE was found to be potentially eligible for the National Register of Historic Places, the Craney Hill Fire Tower. The project proposes no adverse effect on this potentially eligible historic resource.

A Phase IA Archaeological Sensitivity Assessment was completed in April 2023 by Monadnock Archaeology Consulting, LLC for the proposed tower site and utility line. The review found that “the project area is located adjacent to an existing watchtower on steeply sloping, rocky terrain. No archaeological sites or areas of archaeological sensitivity were identified, and no further study is recommended.”

A full discussion of these conclusions is included in Attachments 8 through 10. Photographs are included in Attachment 11.

ADKE would like to thank you in advance for your Section 106 review of this site with respect to archaeological and architectural historic resources. Please do not hesitate to contact me with any questions regarding this request.

Sincerely,



Audra L. Klumb
Architectural Historian

ATTACHMENTS:

FCC 620 Form and Attachments



List of Attachments to form 620

Attachment 1	Resumes
Attachment 2	Additional Site Information
Attachment 3	Tribal Involvement
Attachment 4	Local Government
Attachment 5	Public Involvement
Attachment 6	Additional Consulting Parties
Attachment 7	Areas of Potential Effects
Attachment 8	Historic Properties Identified in the APE for Visual Effects
Attachment 9	Historic Properties Identified in the APE for Direct Effects
Attachment 10	Effects on Identified Properties
Attachment 11	Photographs
Attachment 12	Maps
Attachment 13	References



Attachment 1
Resumes

Audra L. Klumb – Architectural Historian, A&D Klumb Environmental, LLC

Robert Goodby – Monadnock Archaeological Consulting, LLC



Representative Experience

Audra L. Klumb is the co-founder and President of A&D Klumb Environmental, LLC (2003). A&D Klumb Environmental, LLC (ADKE) is an environmental consulting company specializing in environmental reviews and permitting for wetlands, Section 106, NEPA, and Phase I Environmental Site Assessments. ADKE holds a National Women's Business Enterprise Certification with the Women's Business Enterprise National Council. Ms. Klumb's management within ADKE encompasses all aspects of the company from field work, to report writing, consultant management, and company finances. Ms. Klumb volunteers for state and local Boards and committees including the New Hampshire State Conservation Committee, the Merrimack County Conservation District Board of Supervisors and the Canterbury NH Conservation Commission.

Education

Masters of Arts, Historic Preservation, Plymouth State University, 2014
Graduate Certificate in Historic Preservation, Plymouth State University, 2012
Wetland Delineation Certification; US ACOE, University of New Hampshire, 2002
Bachelor of Science, Animal Science; Bioscience and Technology, University of New Hampshire, 1996

Professional Qualifications, Certifications, and Licenses

Secretary of the Interior Qualified Architectural Historian (36 CFR Part 61)
Certified Erosion Sediment and Storm Water Inspector, CESSWI #3504
New Hampshire Certified Wetland Scientist #222
New Hampshire Licensed Septic Designer #1684

Technical Specialties

Ms. Klumb has over 20 years of environmental consulting experience encompassing:

- Wetland Delineation, Mapping, and Permitting
- Wetland Mitigation Planning and Design
- Wetland Restoration
- Section 106 Historic Review/Reports
- National Environmental Policy Act Review/Reports
- Phase I Environmental Site Assessments
- Environmental Assessments
- Endangered Species Research
- Baseline Documentation Reports
- Balloon Tests/Visibility Surveys
- Telecommunication Tower and Antenna Simulations
- Telecommunication Site and Switch Audits

Volunteer Positions

Merrimack County Conservation District – Board of Supervisors: Supervisor 2015-present and
Associate Supervisor 2013-2014
New Hampshire State Conservation Committee: 2017-2022
Canterbury, NH Conservation Commission 2022- Present

Professional Affiliations

New Hampshire Association of Natural Resource Scientists, Concord, NH
Society of Soil Scientists of Northern New England, Durham, NH
Granite State Onsite Wastewater Association, Concord, NH
Maine Association of Wetland Scientists, Portland, ME
New Hampshire Preservation Alliance, Concord, NH
The Association of State Wetland Managers, Windham, ME
Society of Wetland Scientists, McLean, VA
The Planetary Society, Pasadena, CA

Robert G. Goodby, Ph.D.
Monadnock Archaeological Consulting, LLC
144 Greenwood Road, Dublin, NH
03444
(603)563-8123

EDUCATION

Brown University, Ph.D. (Anthropology) 1994
Brown University, M.A. (Anthropology) 1988
University of New Hampshire, B.A. (Anthropology) 1986

FIELD RESEARCH

Founder and Principal Investigator, Monadnock Archaeological Consulting, LLC. 2004-present. Director, Monadnock Archaeological Project, Franklin Pierce University, 2001-present.
Project Archaeologist and Co-Principal Investigator, Victoria Bunker, Inc., 1994-2004.

CULTURAL RESOURCE MANAGEMENT STUDIES

Supervised research and authored over 200 technical reports for all phases of Section 106 archaeological study in New England since 1988 (full list available on request). Certified to conduct Section 106 archaeological studies by the State Historic Preservation Offices of Maine, New Hampshire, and Vermont.

TEACHING EXPERIENCE

Professor, Department of Anthropology, Franklin Pierce University, 20017-present
Associate Professor, Department of Anthropology, Franklin Pierce University, 2005-2017
Assistant Professor, Department of Anthropology, Franklin Pierce College, 2000-2005.

SELECTED PUBLICATIONS

"The Tenant Swamp Site and Paleoindian Domestic Space in Keene, New Hampshire."
Archaeology of Eastern North America 42:129-164. 2014 Senior Author.

"Jack's Reef Points in Northern New England: Exotic Lithics and Long-Distance Interaction in the Post-Hopewell Northeast." *Archaeology of Eastern North America* 41:59-67. 2013.

"11,000 Years on the Ashuelot" in *Where the Mountain Stands Alone*. H. Mansfield, ed. Hanover, NH: University of New England Press, 2006.

"Technological Patterning and Social Boundaries: Ceramic Variability in Southern New England, A.D. 1000-1675" in *Technical Choices and Social Boundaries in Material Culture Patterning*. Miriam Stark, ed. pp. 171-192. Washington, DC: Smithsonian Institution Press. 1998.

ASSOCIATION MEMBERSHIPS

Eastern States Archaeological Federation
Mount Kearsarge Indian Museum (Board member, 2012-2016)
New Hampshire Commission on Native American Affairs (Member, 2011-2016)
New Hampshire Archeological Society (Exec. Board, 1992-94; President, 1994-97)
Northeastern Anthropological Association
Society for American Archaeology

REFERENCES

Available on request.

Attachment 2
Additional Site Information

Site Plans



APPROXIMATE LOCATION OF CENTER OF TOWER:

LATITUDE: 43° 09' 3.03" N
 LONGITUDE: 71° 47' 52.75" W

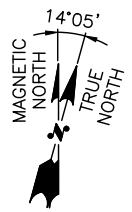
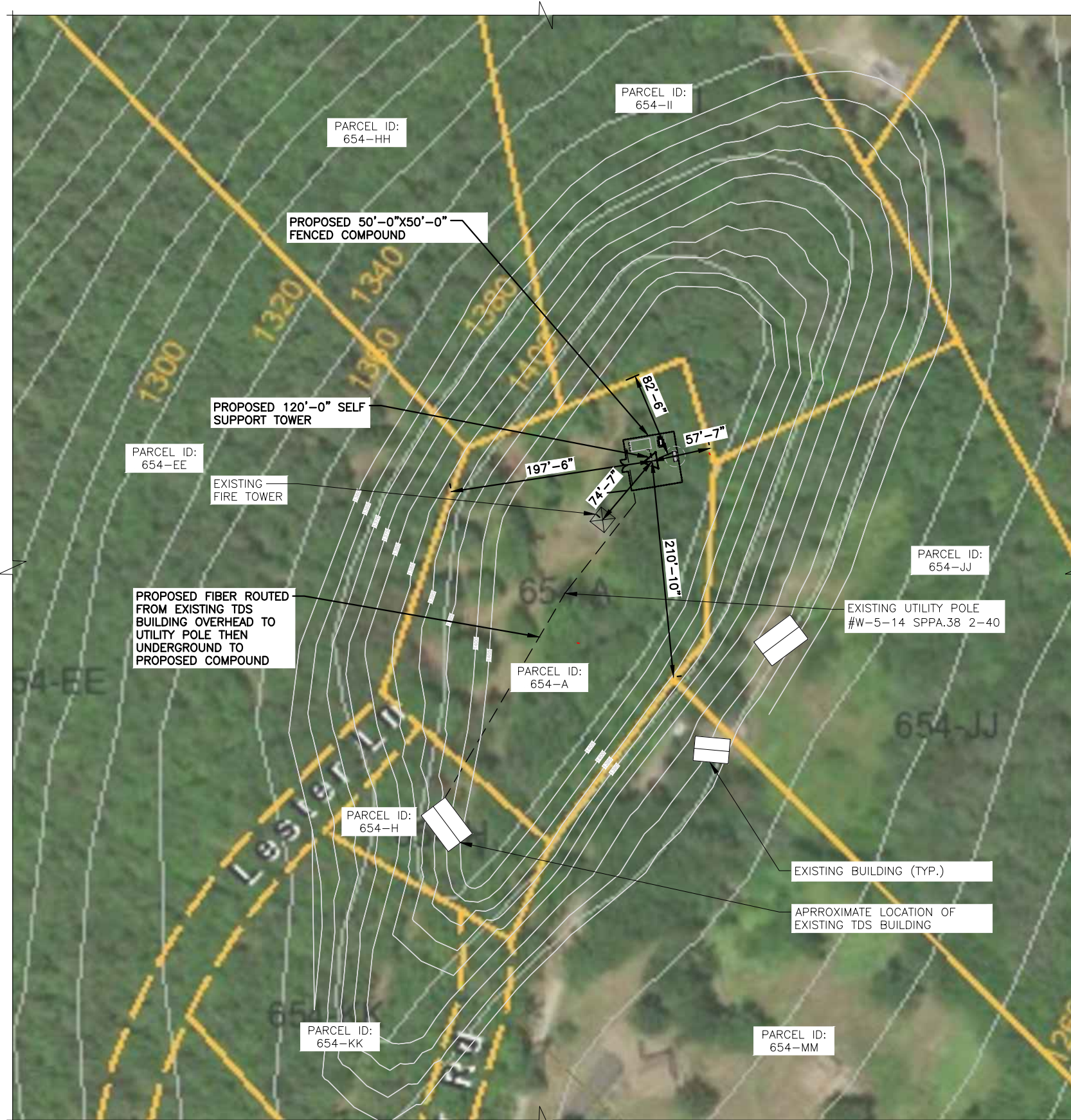

SITE PLAN

22x34 SCALE: 1"=60'
 11x17 SCALE: 1"=120'



1
 LE-1



HENNIKER, NH 03242
 MERRIMACK COUNTY

SITE NAME: CRANEY HILL

CRANEY HILL
 HENNIKER, NH 03242
 MERRIMACK COUNTY

NO.	DATE	REVISIONS	BY	CHK	APP'D
B	04/18/23	ISSUED FOR REVIEW	JS	AT	DPH
A	02/16/23	ISSUED FOR REVIEW	JS	AT	DPH

SCALE: AS SHOWN DESIGNED BY: AT DRAWN BY: JS

TOWN OF HENNIKER, NH		
SITE PLAN		
SITE NAME	DRAWING NUMBER	REV
CRANEY HILL	LE-1	B

APPROXIMATE LOCATION OF CENTER OF TOWER:
 LATITUDE: 43° 09' 3.03" N
 LONGITUDE: 71° 47' 52.75" W

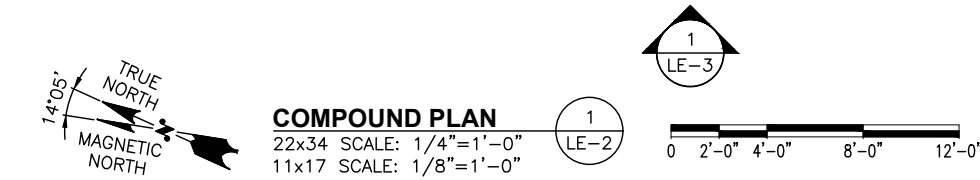
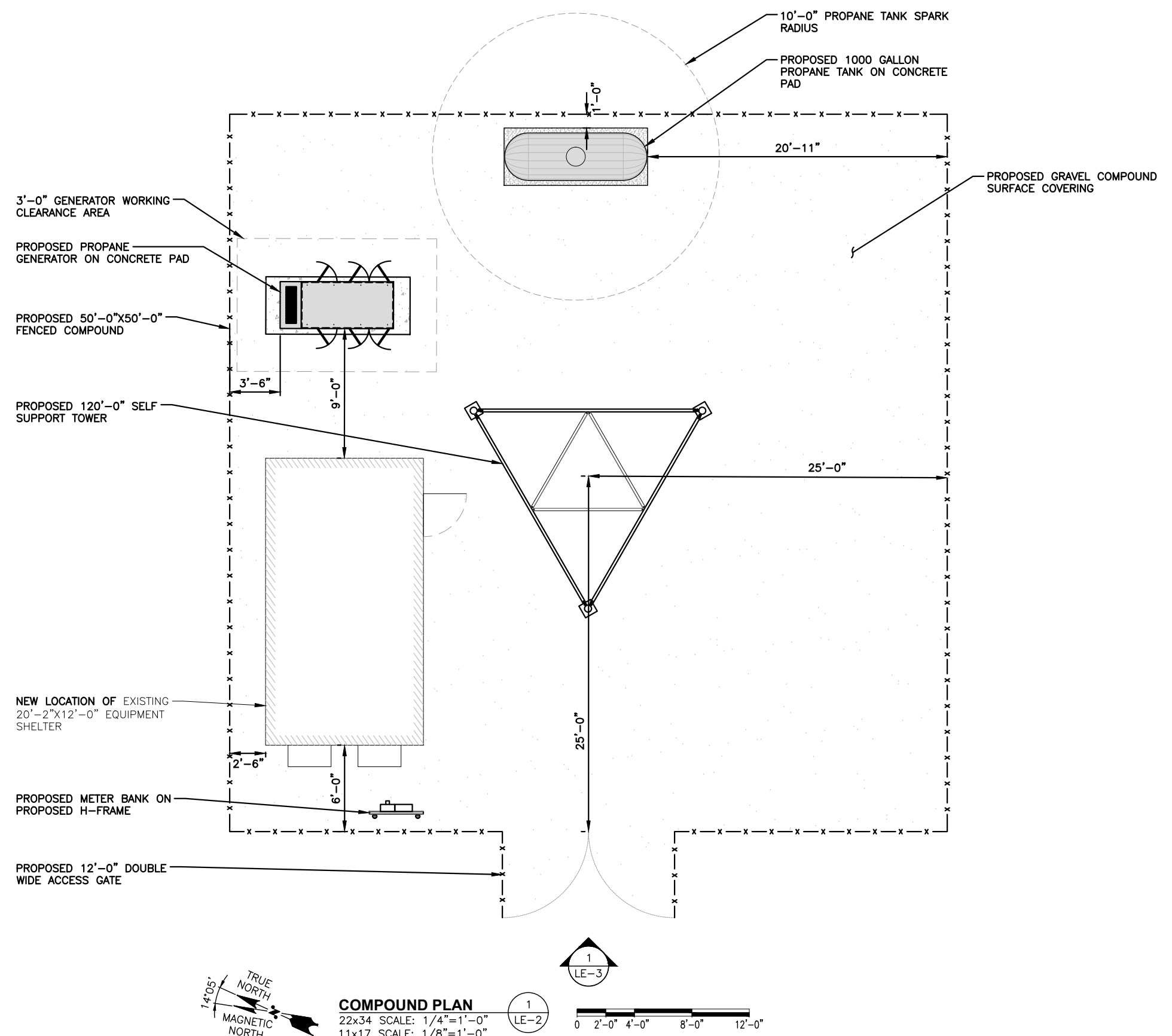

SITE NAME: CRANEY HILL

CRANEY HILL
 HENNIKER, NH 03242
 MERRIMACK COUNTY

NO.	DATE	REVISIONS	BY	CHK	APP'D
B	04/18/23	ISSUED FOR REVIEW	JS	AT	DPH
A	02/16/23	ISSUED FOR REVIEW	JS	AT	DPH
SCALE: AS SHOWN		DESIGNED BY: AT	DRAWN BY: JS		

TOWN OF HENNIKER, NH

COMPOUND PLAN

SITE NAME	DRAWING NUMBER	REV
CRANEY HILL	LE-2	B



HENNIKER, NH 03242
 MERRIMACK COUNTY

APPROXIMATE LOCATION OF CENTER OF TOWER:

LATITUDE: 43° 09' 3.03" N
 LONGITUDE: 71° 47' 52.75" W

TOP OF PROPOSED
 SELF-SUPPORT TOWER
 ELEV. = 120'-0"± A.G.L

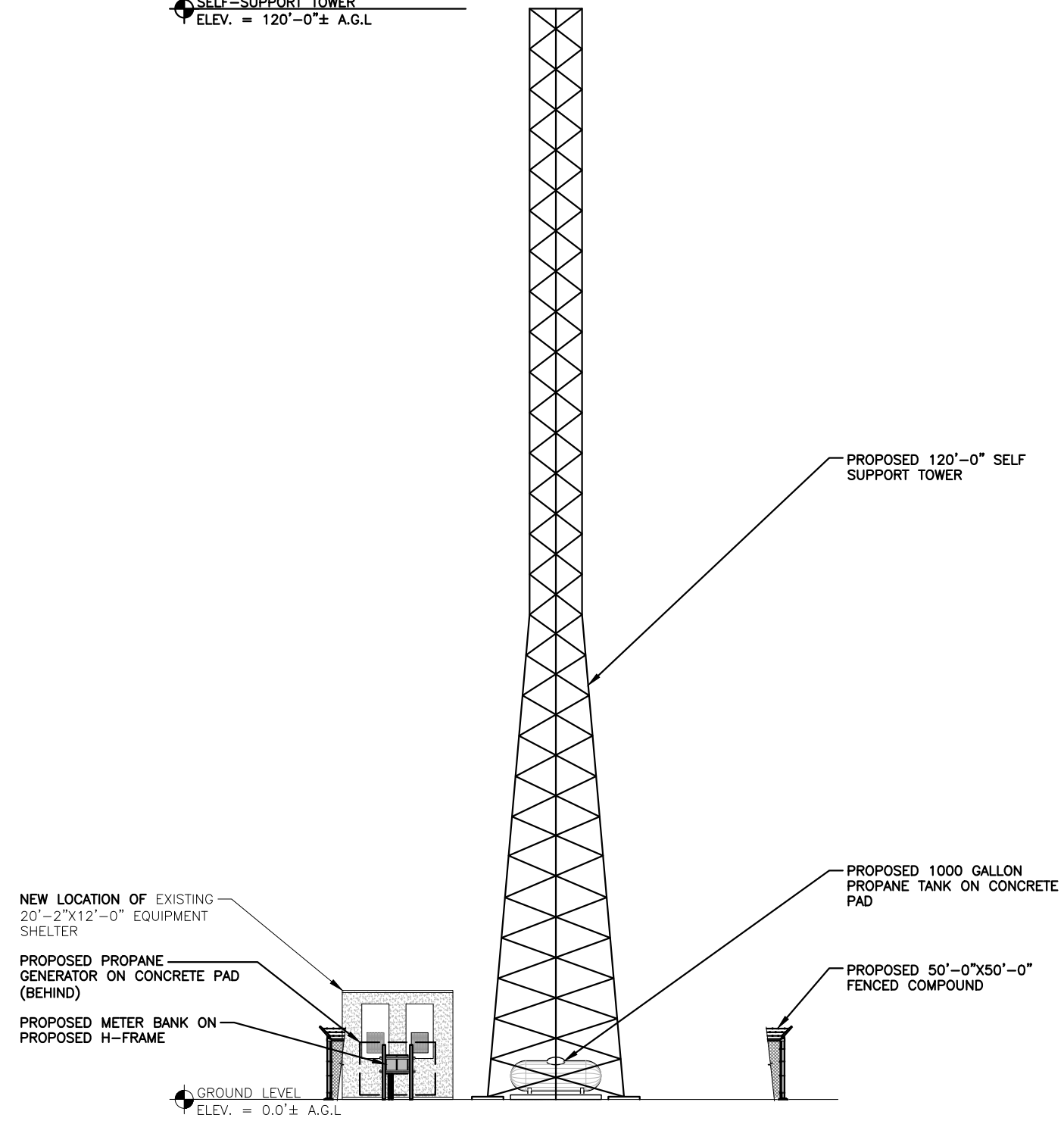

ELEVATION
 22x34 SCALE: 1/8"=1'-0"
 11x17 SCALE: 1/16"=1'-0"

1
 LE-3

0 4'-0" 8'-0" 16'-0" 24'-0"



SITE NAME: CRANEY HILL

CRANEY HILL
 HENNIKER, NH 03242
 MERRIMACK COUNTY

B	04/18/23	ISSUED FOR REVIEW	JS	AT	DPH
A	02/16/23	ISSUED FOR REVIEW	JS	AT	DPH
NO.	DATE	REVISIONS	BY	CHK	APP'D
SCALE: AS SHOWN		DESIGNED BY: AT	DRAWN BY: JS		

B	04/18/23	ISSUED FOR REVIEW	JS	AT	DPH
A	02/16/23	ISSUED FOR REVIEW	JS	AT	DPH
NO.	DATE	REVISIONS	BY	CHK	APP'D
SCALE: AS SHOWN		DESIGNED BY: AT	DRAWN BY: JS		

TOWN OF HENNIKER, NH		
ELEVATION		
SITE NAME	DRAWING NUMBER	REV
CRANEY HILL	LE-3	B

**Attachment 3
Tribal Involvement**

FCC (TCNS) Tribal Notification



From: towernotifyinfo@fcc.gov
To: [adke](#)
Subject: Proposed Tower Structure Info - Email ID #8459227
Date: Friday, February 17, 2023 2:00:14 PM

Dear Audra Klumb,

Thank you for submitting a notification regarding your proposed construction via the Tower Construction Notification System. Note that the system has assigned a unique Notification ID number for this proposed construction. You will need to reference this Notification ID number when you update your project's Status with us.

Below are the details you provided for the construction you have proposed:

Notification Received: 02/17/2023

Notification ID: 262824
Tower Owner Individual or Entity Name: Town of Henniker
Consultant Name: Audra Klumb
Street Address: 34 Centennial Drive
City: Webster
State: NEW HAMPSHIRE
Zip Code: 03303
Phone: 603-746-5065
Email: klumbenvironmental@klumbenv.com

Structure Type: LTOWER - Lattice Tower
Latitude: 43 deg 09 min 3.0 sec N
Longitude: 71 deg 47 min 52.7 sec W
Location Description: Craney Hill
City: Henniker
State: NEW HAMPSHIRE
County: MERRIMACK

Detailed Description of Project: A 120-foot tall lattice communication tower will be constructed at the listed coordinates.

Ground Elevation: 424.3 meters
Support Structure: 36.6 meters above ground level
Overall Structure: 36.6 meters above ground level
Overall Height AMSL: 460.9 meters above mean sea level

From: towernotifyinfo@fcc.gov
To: adke
Cc: tcnweekly@fcc.gov
Subject: NOTICE OF ORGANIZATION(S) WHICH WERE SENT PROPOSED TOWER CONSTRUCTION NOTIFICATION INFORMATION - Email ID #8461101
Date: Friday, February 24, 2023 3:45:46 AM

Dear Applicant:

Thank you for using the Federal Communications Commission's (FCC) Tower Construction Notification System (TCNS). The purpose of this electronic mail message is to inform you that the following authorized persons were sent the notification that you provided through TCNS, which relates to your proposed antenna structure. The information was forwarded by the FCC to authorized TCNS users by electronic mail and/or regular mail (letter). We note that the review period for all parties begins upon receipt of the Submission Packet pursuant to Section VII.A of the NPA and notifications that do not provide this serve as information only.

Persons who have received the notification that you provided include leaders or their designees of federally-recognized American Indian Tribes, including Alaska Native Villages (collectively "Tribal Nations"), Native Hawaiian Organizations (NHOs), and State Historic Preservation Officers (SHPOs). For your convenience in identifying the referenced Tribal Nations and NHOs and in making further contacts, the City and State of the Seat of Government for each Tribal Nation and NHO, as well as the designated contact person, is included in the listing below. We note that Tribal Nations may have Section 106 cultural interests in ancestral homelands or other locations that are far removed from their current Seat of Government. Pursuant to the Commission's rules as set forth in the Nationwide Programmatic Agreement for Review of Effects on Historic Properties for Certain Undertakings Approved by the Federal Communications Commission (NPA), all Tribal Nations and NHOs listed below must be afforded a reasonable opportunity to respond to this notification, consistent with the procedures set forth below, unless the proposed construction falls within an exclusion designated by the Tribal Nation or NHO. (NPA, Section IV.F.4).

The notification that you provided was forwarded to the following Tribal Nations and NHOs. A Tribal Nation or NHO may not respond until a full Submission Packet is provided. If, upon receipt, the Tribal Nation or NHO does not respond within a reasonable time, you should make a reasonable effort at follow-up contact, unless the Tribal Nation or NHO has agreed to different procedures (NPA, Section IV.F.5). In the event a Tribal Nation or NHO does not respond to a follow-up inquiry, or if a substantive or procedural disagreement arises between you and a Tribal Nation or NHO, you must seek guidance from the Commission (NPA, Section IV.G). These procedures are further set forth in the FCC's Second Report and Order released on March 30, 2018 (FCC 18-30).

1. Chief of Staff Audrey Lee - Sac and Fox Nation - 920883 S. Hwy 99, Building A Stroud, OK - cos@sacandfoxnation-nsn.gov; sacandfoxtcns@gmail.com - 918-968-3526 (ext: 1010) - electronic mail and regular mail

2. THPO Edith Leoso - Bad River Band of Lake Superior Tribe of Chippewa Indians - (PO Box: 39) Odanah, WI - thpo@badriver-nsn.gov; deputyTHPO@badriver-nsn.gov - 715-682-7123 - electronic mail

If the applicant/tower builder receives no response from the Bad River Band of Lake Superior Tribe of Chippewa Indians within 30 days after notification through TCNS, the Bad River Band of Lake Superior Tribe of Chippewa Indians has no interest in participating in pre-construction review for the proposed site. The Applicant/tower builder,

however, must immediately notify the Bad River Band of Lake Superior Tribe of Chippewa Indians in the event archaeological properties or human remains are discovered during construction, consistent with Section IX of the Nationwide Programmatic Agreement and applicable law.

3. THPO Marvin DeFoe - Red Cliff Band of Lake Superior Chippewa Indians of Wisconsin - 88455 Pike Road, HWY 13 Bayfield, WI - Marvin.DeFoe@redcliff-nsn.gov; Edwina.Buffalo-Reyes@redcliff-nsn.gov - 715-779-3761 - electronic mail

Exclusions: Boozhoo, we do not have the Red Cliff Portal site online anymore and apologize for the inconvenience.

If you have a project that has already been paid for or would like to voluntarily pay for, please email documents for project review to THPO@redcliff-nsn.gov. This address is only to be used by Consultants who are voluntarily paying for projects.

If you have any questions, please contact Marvin Defoe, THPO Manager at (715) 779-3700 Ext. 4244 or Edwina Buffalo-Reyes, THPO Assistant at (715) 779-3700Ext. 4243.

4. THPO Sarah E Thompson - Lac du Flambeau Band of Lake Superior Chippewa Indians - Tribal Historic Preservation Office (PO Box: 67) Lac du Flambeau, WI - ldfthpo@ldftribe.com - 715-588-2139 - electronic mail
Exclusions: Effective Immediately:

Please send all submissions through email until further notice. Effective 3/23/2020

Please email all submissions to ldfthpo@ldftribe.com

Thank you

5. THPO John Brown - Narragansett Indian Tribe - 4425 South County Trail Charleston, RI - tashtesook@aol.com - 401-585-0142 - electronic mail

The notification that you provided was also forwarded to the following SHPOs in the State in which you propose to construct and neighboring States. The information was provided to these SHPOs as a courtesy for their information and planning. You need make no effort at this time to follow up with any SHPO that does not respond to this notification. Prior to construction, you must provide the SHPO of the State in which you propose to construct (or the Tribal Historic Preservation Officer, if the project will be located on certain Tribal lands), with a Submission Packet pursuant to Section VII.A of the NPA unless the project is excluded from SHPO review under Section III D or E of the NPA.

6. Deputy SHPO Kirk F Mohney - Maine Historic Preservation Commission - 55 Capitol Street Station 65 Augusta, ME - kirk.mohney@maine.gov - -- - electronic mail

7. SHPO Cara Metz - Massachusetts Historical Commission - 220 Morrissey Boulevard Boston, MA - cara.metz@sec.state.ma.us - 617-727-8470 - electronic mail

8. Deputy SHPO Nadine Miller - NH Division of Historical Resources - 19 Pillsbury Street Concord, NH - nadine.m.miller@dncr.nh.gov; marika.s.labash@dncr.nh.gov - 603-271-6628 - electronic mail

9. Preservation Planner Emily Paulus - NH Division of Historical Resources - 19 Pillsbury Street Concord, NH - Emily.Paulus@dcr.nh.gov - 603-271-6628 - electronic mail

10. SHPO Laura V Trieschmann - Vermont Division for Historic Preservation - National Life Building Drawer 20 Montpelier, VT - laura.trieschmann@vermont.gov - 802-828-3222 - electronic mail

TCNS automatically forwards all notifications to all Tribal Nations and SHPOs that have an expressed interest in the geographic area of a proposal. However, if a proposal for PTC wayside poles falls within a designated exclusion, you need not expect any response and need not pursue any additional process with that Tribal Nation or SHPO. In addition, a particular Tribal Nation or SHPO may also set forth policies or procedures within its details box that exclude from review certain facilities (for example, a statement that it does not review collocations with no ground disturbance; or that indicates that no response within 30 days indicates no interest in participating in pre-construction review).

Please be advised that the FCC cannot guarantee that the contact(s) listed above have opened and reviewed an electronic or regular mail notification. If you learn that any of the above contact information is no longer valid, please contact the FCC by emailing tenshelp@fcc.gov. The following information relating to the proposed tower was forwarded to the person(s) listed above:

Notification Received: 02/17/2023
Notification ID: 262824
Excluded from SHPO Review: No
Tower Owner Individual or Entity Name: Town of Henniker
Consultant Name: Audra Klumb
Street Address: 34 Centennial Drive
City: Webster
State: NEW HAMPSHIRE
Zip Code: 03303
Phone: 603-746-5065
Email: klumbenvironmental@klumbenv.com

Structure Type: LTOWER - Lattice Tower
Latitude: 43 deg 9 min 3.0 sec N
Longitude: 71 deg 47 min 52.7 sec W
Location Description: Craney Hill
City: Henniker
State: NEW HAMPSHIRE
County: MERRIMACK
Detailed Description of Project: A 120-foot tall lattice communication tower will be constructed at the listed

coordinates.

Ground Elevation: 424.3 meters

Support Structure: 36.6 meters above ground level

Overall Structure: 36.6 meters above ground level

Overall Height AMSL: 460.9 meters above mean sea level

If you have any questions or comments regarding this notice, please contact the FCC using the electronic Help Request form located on the FCC's website at:

<https://www.fcc.gov/wireless/available-support-services>

You may also call the FCC Support Center at (877) 480-3201 (TTY 717-338-2824). Hours are from 8:00 a.m. to 6:00 p.m. Eastern Time, Monday through Friday (except Federal holidays). To provide quality service and ensure security, all telephone calls are recorded.

Thank you,
Federal Communications Commission

From: towernotifyinfo@fcc.gov
To: adke
Cc: tcons.fccarchive@fcc.gov; ldfthpo@ldftribe.com
Subject: Reply to Proposed Tower Structure (Notification ID: 262824) - Email ID #8462985
Date: Wednesday, February 22, 2023 7:58:48 AM

Dear Audra Klumb,

Thank you for using the Federal Communications Commission's (FCC) Tower Construction Notification System (TCNS). The purpose of this email is to inform you that an authorized user of the TCNS has replied to a proposed tower construction notification that you had submitted through the TCNS.

The following message has been sent to you from THPO Sarah E Thompson of the Lac du Flambeau Band of Lake Superior Chippewa Indians in reference to Notification ID #262824:

Please forward the following information: a short summary of all proposed activity within the project area, Legal Description of the Area of Potential Effects, Topo maps identifying the proposed area, and copies of any studies that have already been conducted regarding cultural resources and archeology in their full format, including reports on archeological and cultural sites identified.

Should you have any questions, please feel free to contact me at 715-588-2139 or ldfthpo@ldftribe.com

Please send requested information to:

Sarah E. Thompson, THPO
Lac du Flambeau Band of Lake Superior Chippewa Indians THPO P.O. Box 67 (Postal)
418 Little Pines (FedEx Mailing Address) Lac du Flambeau, WI 54538 Or ldfthpo@ldftribe.com

For your convenience, the information you submitted for this notification is detailed below.

Notification Received: 02/17/2023
Notification ID: 262824
Tower Owner Individual or Entity Name: Town of Henniker
Consultant Name: Audra Klumb
Street Address: 34 Centennial Drive
City: Webster
State: NEW HAMPSHIRE
Zip Code: 03303
Phone: 603-746-5065
Email: klumbenvironmental@klumbenv.com

Structure Type: LTOWER - Lattice Tower
Latitude: 43 deg 9 min 3.0 sec N
Longitude: 71 deg 47 min 52.7 sec W
Location Description: Craney Hill
City: Henniker
State: NEW HAMPSHIRE
County: MERRIMACK

Detailed Description of Project: A 120-foot tall lattice communication tower will be constructed at the listed coordinates.

Ground Elevation: 424.3 meters

Support Structure: 36.6 meters above ground level

Overall Structure: 36.6 meters above ground level

Overall Height AMSL: 460.9 meters above mean sea level

Attachment 4
Local Government

Town of Henniker

Henniker Historical Society



From: [adke](#)
To: diane.kendall@henniker.org
Subject: Craney Hill Telecommunications Tower
Date: Monday, February 20, 2023 1:42:00 PM
Attachments: [Locus Map - Craney Hill Circle.pdf](#)

Good afternoon Diane,

My company is working for TEP Northeast on the proposed Craney Hill telecommunications tower. My role is to review the proposed tower for direct and indirect impacts on historical resources and submit this information to the State, FCC, and interested Tribes. We will have an archaeologist review the site for archaeological resources and I will evaluate the impacts on standing historical structures.

I was provided your name as the Town contact for the project.

I will be reviewing the ½-mile radius surrounding the proposed tower for historical resources. This radius is shown on the attached Locus Map. I am aware of the Craney Hill Fire Tower historic resource, which was constructed in 1912. Are there any other historic resources within the ½-mile Area of Potential Effects that the town is aware of that I should consider for visual impacts?

I will also reach out to the Henniker Historical Society.

Is there a Friends Group or other association related to the Fire Tower?

Thank you,
Audra

Audra L. Klumb, CWS, CESSWI, Architectural Historian
A&D Klumb Environmental, LLC
34 Centennial Drive
Webster, NH 03303
603-746-5065



A & D Klumb Environmental, LLC

February 20, 2023

Henniker Historical Society
PO Box 674
Henniker, NH 03242

RE: Proposed Telecommunications Tower, Craney Hill, Henniker, NH

Dear Henniker Historical Society,

A & D Klumb Environmental, LLC is conducting a Section 106 architectural review for the proposed Town-owned telecommunication tower to be located on the summit of Craney Hill. The Town proposes to construct a 120-foot tall lattice communication tower at the site, N43° 09' 3.03" W71° 47' 52.75".

The NH Division of Historical Resources and the FCC require that the municipality and any local Historical Commission/Society be notified of this project. ADKE has been retained to determine whether the proposed undertaking will adversely impact properties of historical significance (properties listed on or eligible for listing on the National Register of Historic Places). Our findings will be submitted in a report to the New Hampshire Division of Historical Resources upon the completion of the research.

Please contact me if this project will directly or visually affect historic properties within the vicinity of the project. Included please find a locus map showing the proposed tower location as well as a ½-mile radius circle review area.

Sincerely,

A handwritten signature in black ink that reads "Audra Klumb".

Audra Klumb
President

Enclosure: Project Locus Map

From: adke
To: dpclément@tds.net
Subject: Craney Hill Telecommunications Tower
Date: Monday, February 20, 2023 3:27:00 PM
Attachments: [Locus Map - Craney Hill Circle.pdf](#)

Good afternoon Dale,

My company is working for TEP Northeast on the proposed Town-owned Craney Hill 120-ft tall telecommunications tower which will be located on Craney Hill near the fire tower. My role is to review the proposed tower for direct and indirect impacts on historical resources and submit this information to the State, FCC, and interested Tribes.

Henniker Town Administrator, Diane Kendall provided me your contact information as someone who represents or is associated with the Fire Tower on the property.

I will be reviewing the ½-mile radius surrounding the proposed tower for historical resources. This radius is shown on the attached Locus Map. I am aware of the Craney Hill Fire Tower historic resource, which was constructed in 1912. Do you have any other information on the Fire Tower that you would like to share? Are there any other historic resources within the ½-mile Area of Potential Effects that you are aware of that I should consider for visual impacts from the proposed tower?

Thank you,
Audra

Audra L. Klumb, CWS, CESSWI, Architectural Historian
A&D Klumb Environmental, LLC
34 Centennial Drive
Webster, NH 03303
603-746-5065

**Attachment 5
Public Involvement**

Public Notice

Published in the Granite Quill on April 7, 2023



Classifieds

COMMERCIAL FOR RENT

HENNIKER -- PROFESSIONAL OFFICE OR BUSINESS SPACE: Excellent location on Route 114 in downtown Henniker. Good visibility, off-street parking. 428-3262, days.

PUBLIC NOTICE EMERALD LAKE VILLAGE DISTRICT USE OF FIREWORKS ON DISTRICT BEACHES PUBLIC HEARING

Emerald Lake Village District (ELVD) will hold a Public Hearing on Thursday, April 20, 2023, at 6:30 p.m. at the ELVD office, 147 West Main Street, Hillsborough, NH. The purpose of the hearing is to discuss final draft changes to the Beach Rules & Regulations, specifically, the use of fireworks on ELVD beaches & property.

PUBLIC NOTICE EMERALD LAKE VILLAGE DISTRICT ANNUAL MEETING ANNOUNCEMENT

Emerald Lake Village District is scheduled to hold its annual meeting for election of officials and for warrant articles on April 22, 2023 at the Hillsboro Deering Elementary school located at 4 Hillcat Drive, Hillsboro, NH. Voting for officials will occur between 10:00 AM – 12:00 PM. Annual meeting shall then commence @ 12:30 PM. The Hillsboro Supervisors of the checklist will be in session this same date from 10:00 AM – 12:00 PM offering the final opportunity to register to vote during this year's meeting.

HILLSBORO-DEERING ELEMENTARY SCHOOL

Kindergarten Registration • School Year 2023-2024

Children must reside in Hillsboro, Deering or Windsor and be 5 yrs. old on or before 9/30/2023.

Register Online at <https://www.hdsd.org/Page/6116>. After registering your child, please sign up for a Kindergarten Screening time at <https://www.hdsd.org/Page/6116> to be held at Hillsboro-Deering Elementary School on June 14th and 15th

Kindergarten Parent Information Night will be on May 31st at 5:30pm

JOB OPENING TOWN OF HENNIKER DEPUTY TOWN CLERK TAX COLLECTOR

The Town of Henniker NH is seeking a Full Time Deputy Town Clerk Tax Collector for the Town Clerk Tax Collector's Office. The Deputy Town Clerk Tax Collector is responsible for assisting the Town Clerk and Tax Collector in the daily operations of the Town Clerk Tax Collector's Office. This position requires the applicant to be able to perform daily accounting operations accurately and deal daily with the public, assisting them in all facets of tax collecting and town clerk processes. Successful applicant must be a Henniker resident and have a high school diploma or equivalent, strong computer and organizational skills. Strict observance of confidentiality is a must when dealing with records of the municipality, the applicant must possess a valid NH Driver's License and successfully pass a background investigation. Salary range is \$17.86 - \$19.27 per hour depending on experience. **Full benefits package** includes membership in the NH Retirement System, health, dental, life and disability insurance, paid vacation, sick and holidays. The Town of Henniker is an Equal Opportunity Employer.

An application form is available at the Town Hall, 18 Depot Hill Rd. Henniker, NH or online at <https://www.henniker.org/site-home/pages/employment-opportunities>

Applications and resumes should be mailed to: Town Clerk/Tax Collector 18 Depot Hill Rd., Henniker, NH 03242 or emailed to: deb.aucoin@henniker.org or kim.johnson@henniker.org or left in person at the Town/Clerk Tax Collector's Office, 18 Depot Hill Road, Henniker.

HILLSBORO LIONS

70th Anniversary



We cordially invite you to share in our celebration

DATE: Saturday, April 15, 2023

TIME: 7:00-9:30 PM

PLACE: Hillsboro American Legion Post 59
538 West Main St. Hillsboro

- Appetizers and Desserts will be served
- Cash bar will be available

RSVP: Mary Rogers at mary.morehouse@verani.com or Kathy Audette at audettekh@aol.com

REGISTRATION FOR KINDERGARTEN AND EARLY LEARNING PROGRAM

Washington School District Washington Elementary School School Year 2023-2024

Any Washington resident with a child who will be **five years old by September 30, 2023 will be eligible to enroll in the Kindergarten program.** Please register online at <https://hdsd.web2school.com/> Because all students are in the same classroom, screenings are conducted in the fall. You will receive information about summer kindergarten programming and meet and greet dates with the kindergarten teacher before the end of the current school year.

Any Washington resident with a child who will be **three or four years old by September 30, 2023 will be able to enroll in the Early Learning Program.** Early Learning Program screenings will be scheduled for June and placement will be announced within two weeks from the screening date. Please stop by the school office to pick up a registration packet. You can also access the packet at <https://www.hdsd.org/domain/2419>

A copy of your child's **immunization record, birth certificate, your child's most recent physical examination** as well as **proof of residency** will be needed at the time of registration.

If you have any questions, please contact the office at 495-3463 or email to: dbilski@hdsd.org.

Equal Opportunity Employer/Equal Educational Opportunities

PUBLIC NOTICE:

All interested persons are invited to comment on any potential effects that may be caused to historic properties from a proposed 120-foot tall monopole telecommunications tower to be located at 43° 9' 3.03"N and 71° 47' 52.75"W, on the summit of Craney Hill in Henniker, Merrimack County, NH, if any such properties are located at or near the site. Comments may be submitted, within 30 days of the notice publish date, by email to info@klumbenv.com or by U.S. Mail to A&D Klumb Environmental, LLC, 34 Centennial Drive, Webster, NH 03303, (603) 746-5065. Questions about this facility or this notice may be directed to the above contact information. This notice is provided in accordance with the regulations of the Federal Communications Commission, 47 C.F.R. Part 1, Appendices B and C.

PUBLIC NOTICE HILLSBORO-DEERING SCHOOL DISTRICT 2023 NOMINATIONS FOR THE RICHARD W. WITHINGTON AWARD

The Richard W. Withington Award is granted to a member of the Hillsboro-Deering School District personnel; a teacher, administrator, secretary, custodian, aide, coach, activities director, or other full or part-time employee of the District.

The recipient should be recognized as an ambassador of the school into the Hillsborough community, a person who has strived for and achieved excellence, contributed significantly to the general welfare of the students in ways above and beyond the normal requirements of their job, offered students and adults a model of strong professional behavior and carried this model from the school into the community. Recognition and respect in the Hillsborough community as a representative of the Hillsboro-Deering School District is a key component.

Please submit nominations in writing to:

Dr. Jennifer L. Crawford
Superintendent of Schools
SAU #34
78 School St.
Hillsboro, NH 03244-4870
or
jcrawford@hdsd.org

Deadline for nominations: Friday, May 1, 2023

The Withington Award is determined annually in an amount of at least \$1,000 by a Grant Committee consisting of a representative of the public, the Chairperson of the Hillsboro-Deering School Board, and the Superintendent of Schools.

The award recipient will be announced during the Hillsboro-Deering School District Campus-Wide Family Fun-Fest on May 10, 2023.

Equal Opportunity Employer/Equal Educational Opportunities

**Attachment 6
Additional Consulting Parties**

None



Attachment 7
Areas of Potential Effects

Map of Area Showing Proposed Site and 0.5 Mile Radius Circle



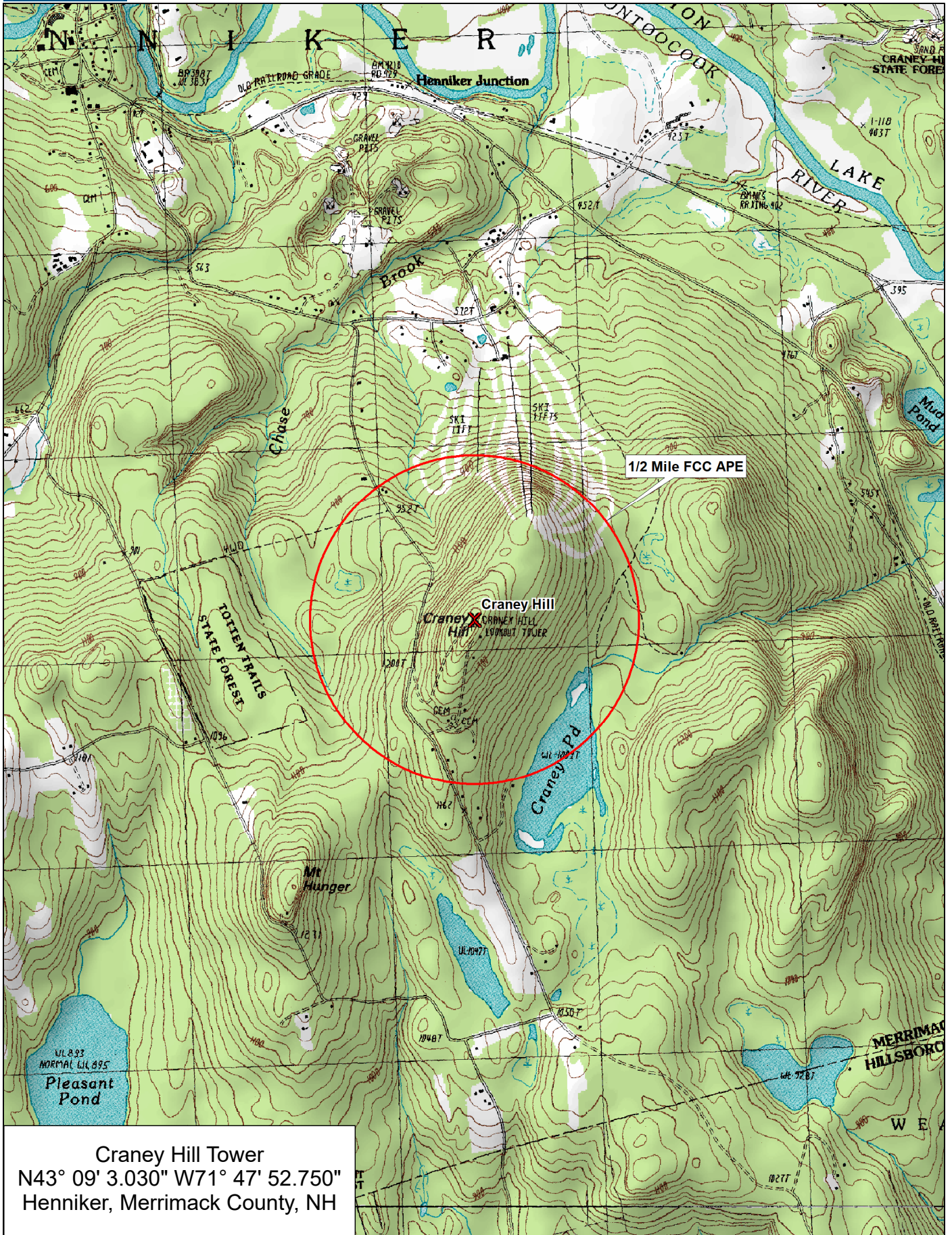

1/2 Mile FCC APE

Craney Hill Tower
 N43° 09' 3.030" W71° 47' 52.750"
 Henniker, Merrimack County, NH

Data use subject to license.

© DeLorme. XMap® 7.

www.delorme.com

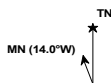

Scale 1 : 25,000

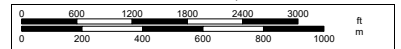

1" = 2,083.3 ft

Data Zoom 13-0

Attachment 8
Historic Properties Identified in the APE for Visual Effect



Historic Properties Identified in the APE for Visual Effect

The tower will be located on the summit of Craney Hill, east of Craney Hill Road, south of Pat's Peak Ski Area, and northwest of Craney Pond. The ½-mile APE includes Craney Hill Road and Tower Road. The majority of the APE is forested with scattered residences. The file review for historic resources conducted on January 19, 2023 and doublechecked on April 17, 2023 online through NH DHR EMMIT database and the National Park Service National Register of Historic Places mapper found that there are no properties within the ½ mile Area of Potential Effects listed on or eligible for listing on the National Register of Historic Places.

On February 21, 2023 ADKE visited the site and walked and drove the public roads within the APE to determine if any properties may be eligible for the National Register of Historic Places. One property within the APE appears to be potentially eligible for the National Register of Historic Places, the Craney Hill Fire Tower.

The existing Craney Hill Fire Tower was constructed in 1939, engineered by International Derrick, Co. In 1973 a new tower cab was constructed above the original metal cab. The tower was part of the State of New Hampshire lookout network until its closure in 1981. The fire tower is owned by the Town of Henniker and stands approximately 51-feet high. The tower was placed on the National Historic Lookout Register in 1997.¹ The Craney Hill Fire Tower shares its steel support structure with inset staircase and wood cab design with many of the other fire towers throughout the state. Many of the fire towers under current use by the state have been formally evaluated and have been determined eligible for the National Register of Historic Places under Criteria A & C, for association with conservation, entertainment/recreation, politics/government, and architecture and engineering. The Craney Hill Fire Tower was constructed as a fire tower in 1939 and would most likely be eligible for the National Register under Criteria A & C as well.

No other properties within the ½-mile APE appeared to rise to the level of significance, when viewed from the public way, to be eligible for the National Register of Historic Places.

¹ Craney Hill Fire Tower details from Fire Lookout web site:
<http://www.firelookout.org/lookouts/nh/craney.htm>



Attachment 9
Historic Properties Identified in the APE for Direct Effect



Historic Properties Identified in the APE for Direct Effect

A Phase IA Archaeological Sensitivity Assessment was completed on April 15, 2023 by Monadnock Archaeology Consulting, LLC. The archaeology review was completed for the proposed tower site and utility line. The review found that “Project area is located adjacent to an existing watchtower on steeply sloping, rocky terrain. No archaeological sites or areas of archaeological sensitivity were identified, and no further study is recommended.” The report is considered confidential, not for public distribution and is available upon request.



Attachment 10
Effects on Identified Properties



Effects on Identified Properties

Visual effects

The proposed lattice telecommunication tower is to be located within a wooded area approximately 75-feet northeast of the Craney Hill Fire Tower. The Craney Hill Fire Tower is presumed to be eligible for the National Register of Historic Places under Criteria A & C for its association with conservation, entertainment/recreation, politics/government, and architecture and engineering. The proposed telecommunication tower will be located within the vicinity of the Craney Hill Fire Tower, but would not reduce the Fire Tower's eligibility for the National Register of Historic Places under Criteria A or C.

The Oak Hill Fire Tower (LOU-0410) located in Loudon, NH was reviewed for comparison (see Photo 11 within Attachment11). The Oak Hill Fire Tower is owned by the State of New Hampshire. It was constructed in 1928 and had a new cab installed in 2019. The Oak Hill Fire Tower is located within 50-feet of a lattice telecommunication tower. The Oak Hill Fire Tower was evaluated and determined eligible for the National Register of Historic Places in 2022 under Criterion A and C for its association with conservation, entertainment/recreation, politics/government, and architecture and engineering. The proximity of the lattice tower near the Oak Hill Fire Tower does not detract from the NR eligibility criteria for that historic resource.

The Craney Hill Fire Tower appears to be eligible for the National Register under the same criterion as the Oak Hill Fire Tower and other NR eligible fire towers throughout the state because of the same or similar historic associations to conservation, entertainment/recreation, politics/government, and architecture and engineering. The telecommunication tower construction on Craney Hill would not take away from these NR eligibility criteria. Therefore, the construction of a lattice telecommunication tower in the vicinity of the Craney Hill Fire Tower would not pose an adverse effect on the eligibility of the fire tower for the National Register of Historic Places.

Direct Effects

A Phase IA Archaeological Sensitivity Assessment was completed on April 15, 2023 by Monadnock Archaeology Consulting, LLC. The archaeology review was completed for the proposed tower site and utility line. The review found that "Project area is located adjacent to an existing watchtower on steeply sloping, rocky terrain. No archaeological sites or areas of archaeological sensitivity were identified, and no further study is recommended." The report is considered confidential, not for public distribution and is available upon request.



Attachment 11
Photographs





Photo 1. View east of the access road entry at Craney Hill Road.



Photo 2. View northeast of the Craney Hill Fire Tower from the access road.





Photo 3. View south of the TDS building where the utilities will lead to the site.



Photo 4. View north from the utility building along the overhead utility line.





Photo 5. View east of the Craney Hill Fire Tower. The telecommunications tower will be located to the left of the fire tower, beyond the closer pine trees.





Photo 6. View southwest at the proposed tower site with the fire tower in the distance.



Photo 7. View north across the proposed tower site.





Photo 8. View south across the proposed tower site.



Photo 9. View east across the proposed tower site.





Photo 10. View southwest along a hiking trail toward the proposed tower site, beyond the large rock, with the fire tower in the distance.





Photo 11. View northeast of the Oak Hill Fire Tower in Loudon, NH (LOU-0410), with the lattice telecommunication tower located within 50-ft.



Attachment 12
Maps

Historic Topographic Maps:

1926 Hillsboro NH USGS Topographic Map
1957 Hillsboro NH USGS Topographic Map



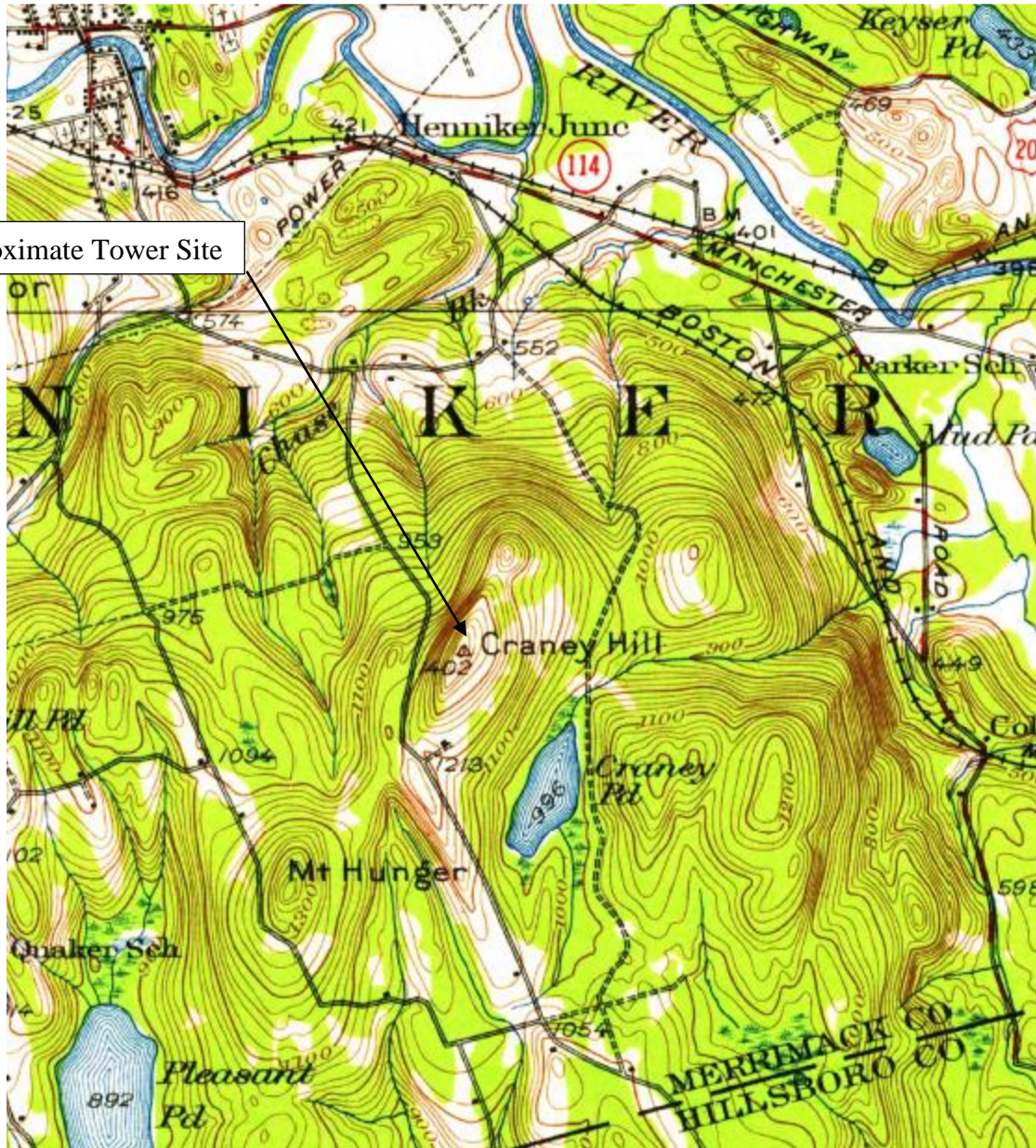

1926 Hillsboro NH USGS Topographic Map



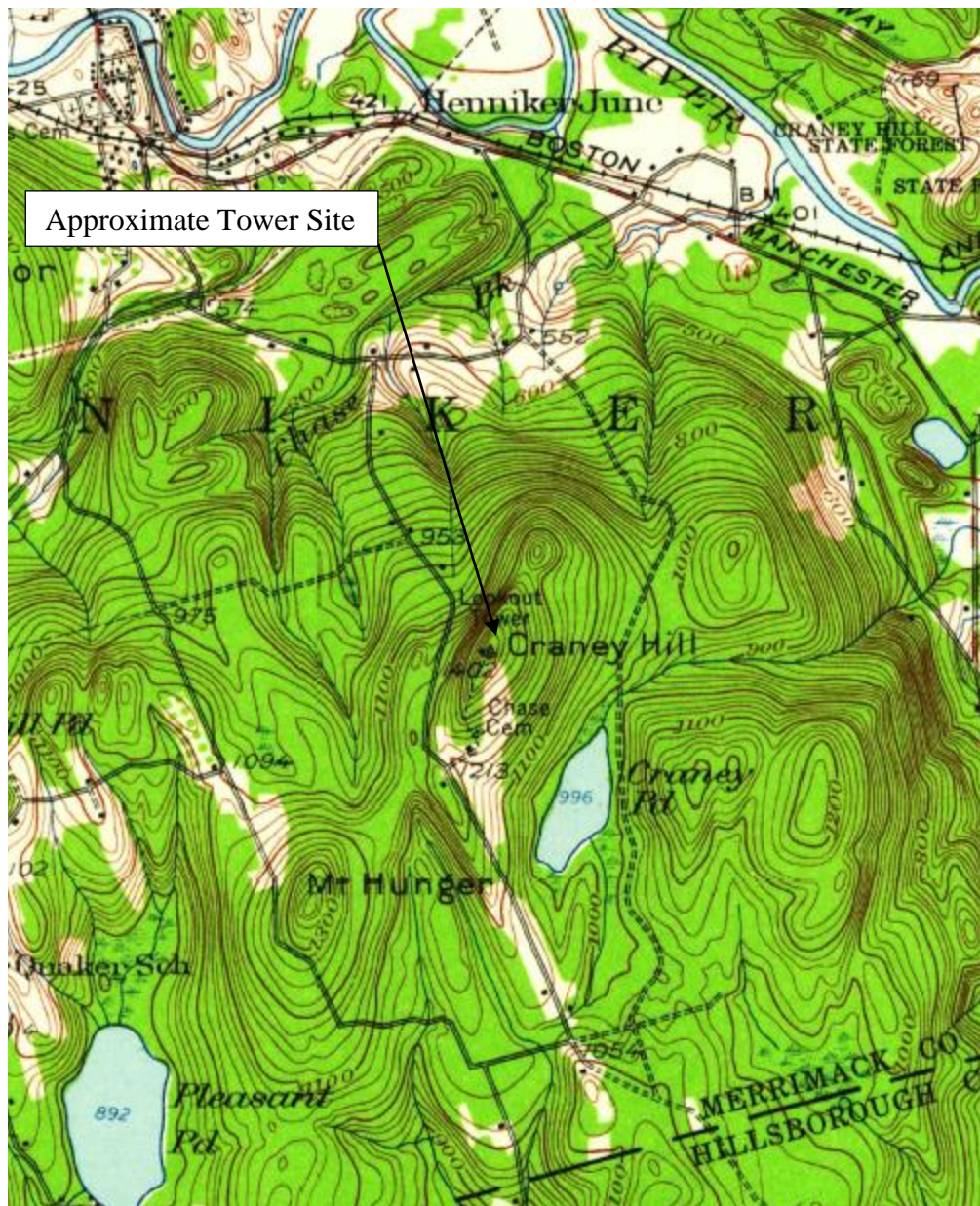

1957 Hillsboro NH USGS Topographic Map



**Attachment 13
References**



References:

Forest Fire Lookout Association Web Site, New Hampshire Fire Towers, Craney Hill Tower. Accessed February 17, 2023 at:
<http://www.firelookout.org/lookouts/nh/craney.htm>

National Register of Historic Places; Accessed March 30, 2023
<https://www.nps.gov/maps/full.html?mapId=7ad17cc9-b808-4ff8-a2f9-a99909164466>

New Hampshire Division of Historical Resources, 19 Pillsbury Street, Concord, NH
online File review January 19, 2023, March 29, 2023, and April 17, 2023
<https://emmit.dncr.nh.gov/Login.aspx?showDisc=false>

State of new Hampshire Biennial Report of the Forestry and Recreation Commission for the
Two Fiscal Years Ending in June 30, 1940 pg.10

TopoView for Historic USGS Topographic Maps accessed March 30, 2023
<https://ngmdb.usgs.gov/topoview/viewer/>



APPROXIMATE LOCATION OF CENTER OF TOWER:

LATITUDE: 43° 09' 3.03" N
 LONGITUDE: 71° 47' 52.75" W

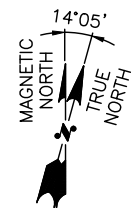
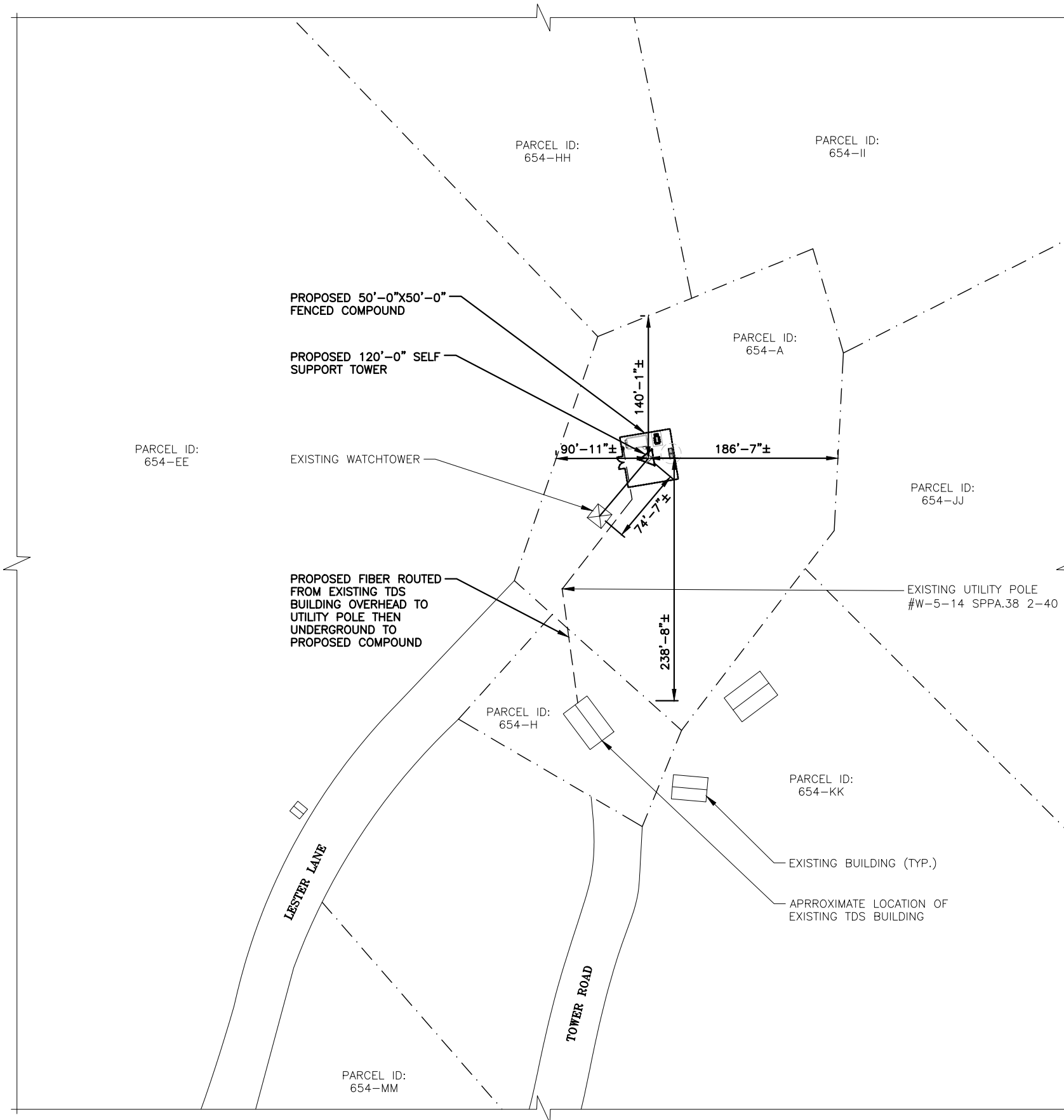

SITE PLAN

22x34 SCALE: 1"=60'
 11x17 SCALE: 1"=120'



1
 LE-1



HENNIKER, NH 03242
 MERRIMACK COUNTY

SITE NAME: CRANEY HILL

CRANEY HILL
 HENNIKER, NH 03242
 MERRIMACK COUNTY

NO.	DATE	REVISIONS	BY	CHK	APP'D
A	02/16/23	ISSUED FOR REVIEW	JS	AT	DPH
SCALE: AS SHOWN		DESIGNED BY: AT	DRAWN BY: JS		

TOWN OF HENNIKER, NH

SITE PLAN

SITE NAME	DRAWING NUMBER	REV
CRANEY HILL	LE-1	A

APPROXIMATE LOCATION OF CENTER OF TOWER:
 LATITUDE: 43° 09' 3.03" N
 LONGITUDE: 71° 47' 52.75" W

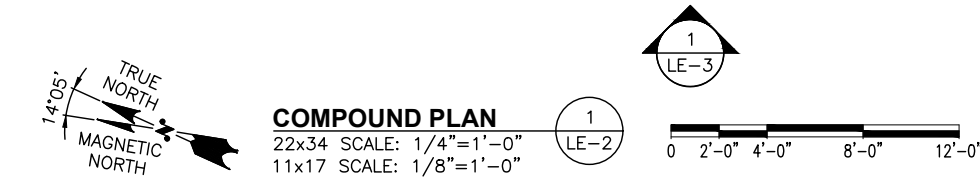
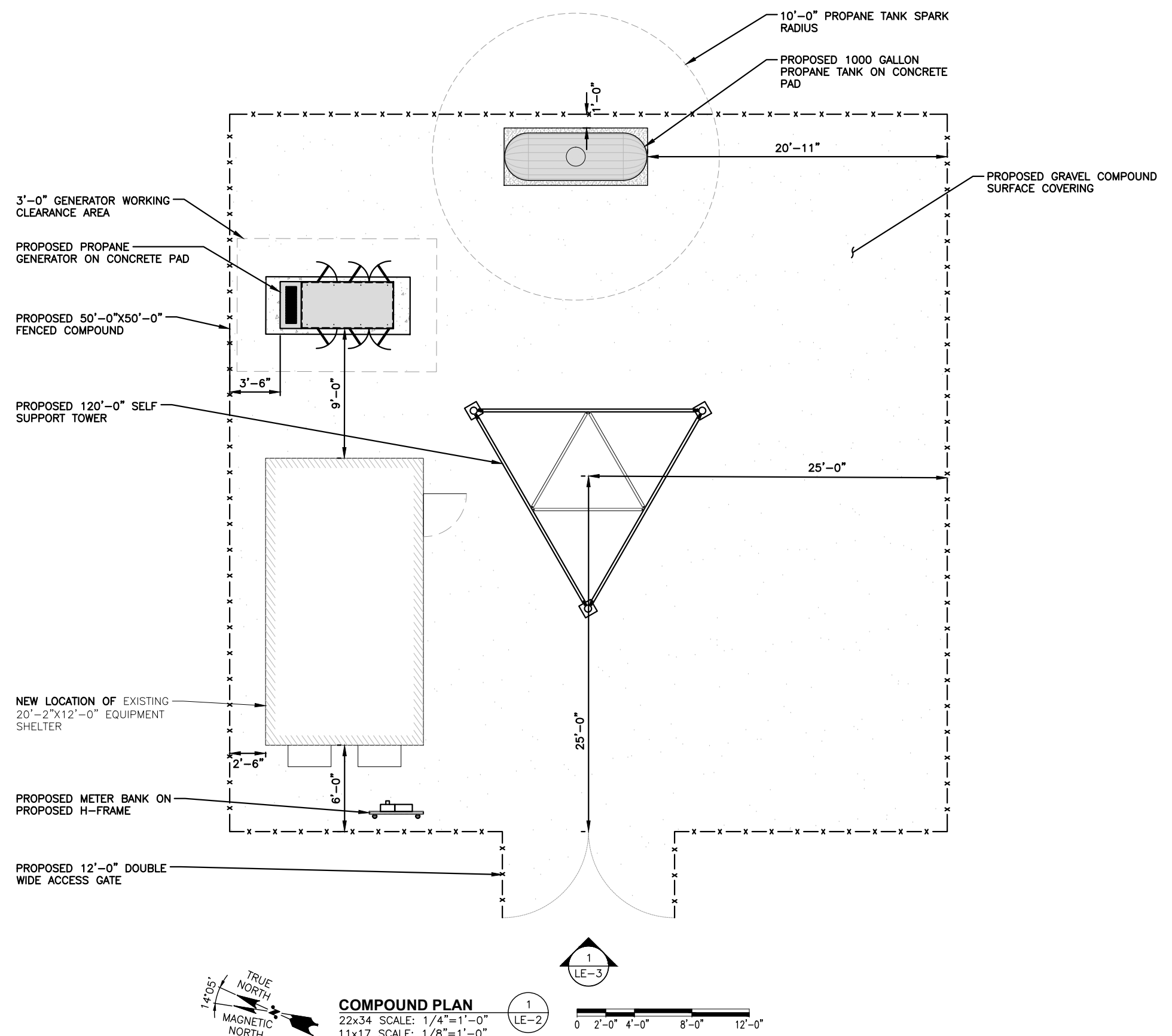

COMPOUND PLAN
 22x34 SCALE: 1/4"=1'-0"
 11x17 SCALE: 1/8"=1'-0"



HENNIKER, NH 03242
 MERRIMACK COUNTY

SITE NAME: CRANEY HILL

CRANEY HILL
 HENNIKER, NH 03242
 MERRIMACK COUNTY

NO.	DATE	ISSUED FOR REVIEW	BY	CHK	APP'D
A	02/16/23	ISSUED FOR REVIEW	JS	AT	DPH
SCALE: AS SHOWN		DESIGNED BY: AT	DRAWN BY: JS		

TOWN OF HENNIKER, NH

COMPOUND PLAN

SITE NAME	DRAWING NUMBER	REV
CRANEY HILL	LE-2	A

APPROXIMATE LOCATION OF CENTER OF TOWER:

LATITUDE: 43° 09' 3.03" N
 LONGITUDE: 71° 47' 52.75" W

TOP OF PROPOSED
 SELF-SUPPORT TOWER
 ELEV. = 120'-0"± A.G.L

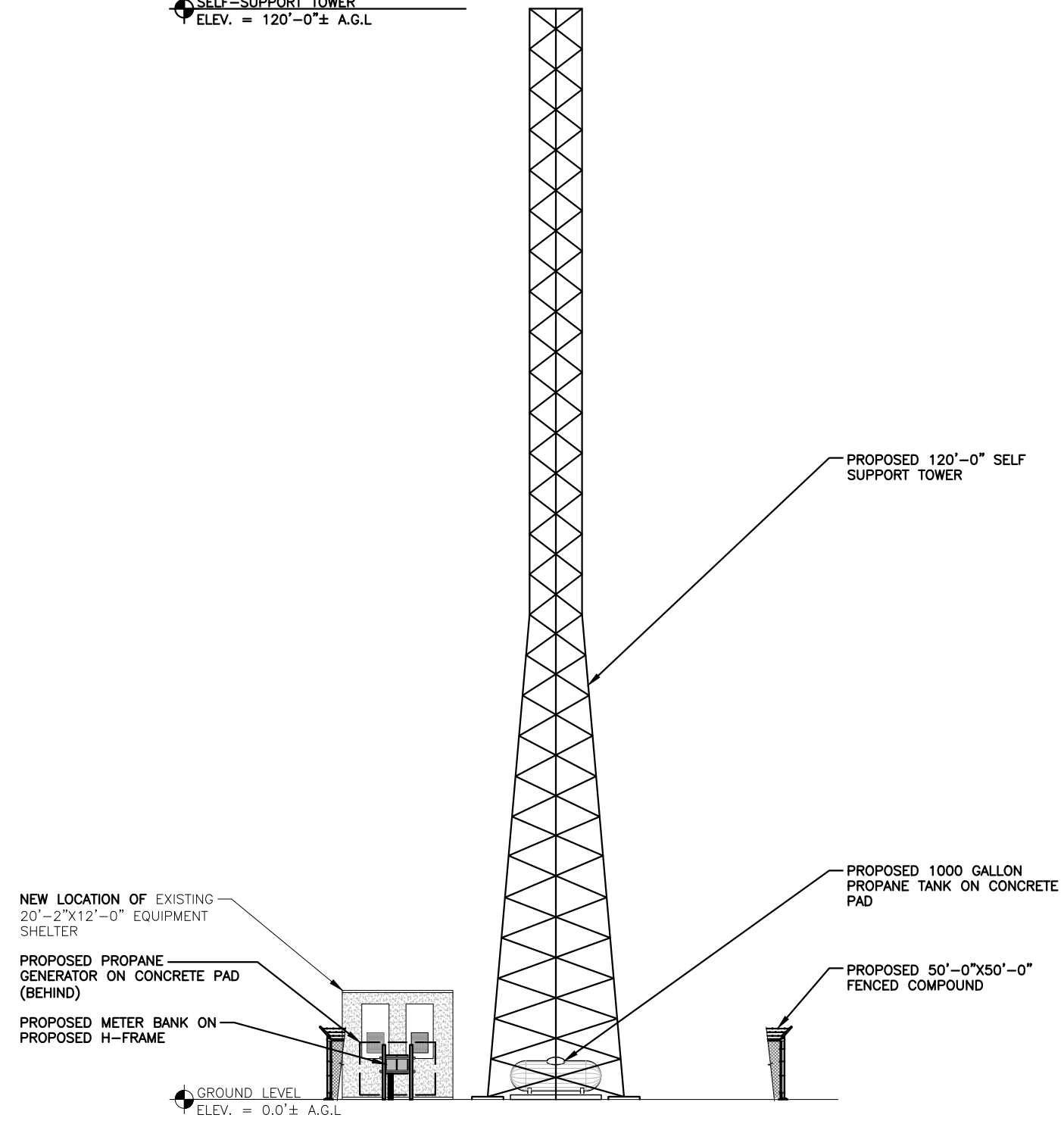

GROUND LEVEL
 ELEV. = 0.0'± A.G.L

ELEVATION

22x34 SCALE: 1/8"=1'-0"
 11x17 SCALE: 1/16"=1'-0"

1
 LE-3



HENNIKER, NH 03242
 MERRIMACK COUNTY

SITE NAME: CRANEY HILL

CRANEY HILL
 HENNIKER, NH 03242
 MERRIMACK COUNTY

NO.	DATE	ISSUED FOR REVIEW	BY	CHK	APP'D
A	02/16/23	ISSUED FOR REVIEW	JS	AT	DPH
SCALE: AS SHOWN		DESIGNED BY: AT	DRAWN BY: JS		

TOWN OF HENNIKER, NH

ELEVATION

SITE NAME	DRAWING NUMBER	REV
CRANEY HILL	LE-3	A