

BOS AGENDA

FOR WEB PUBLICATION





TOWN OF HENNIKER, NEW HAMPSHIRE
SELECTMEN & SEWER COMMISSIONERS
AGENDA

Place: Henniker Community Center 57 Main Street
Henniker, NH 03242

Tuesday February 20, 2024
6:15pm

I. 6:15 CALL TO ORDER REGULAR PUBLIC SESSION

II. PLEDGE OF ALLEGIANCE

III. ANNOUNCEMENTS

IV. CONSENT AGENDA

1) [Consent Agenda February 20, 2024](#)

V. PUBLIC COMMENT #1 – (For any comment by any Henniker resident on a topic. Request time limit, up to 3 minutes)

VI. APPOINTMENTS WITH THE BOARD

2) [Monica Rico – Special Event Permit, Henniker Handmade & Homegrown](#)

VII. NEW BUSINESS

3) [Leo Aucoin, Highway Supt. – Truck & Truck Body Bid Awards](#) & [2024 Paving Contract Extension](#)

4) [Selectmen schedule for Town Voting March 12th](#)

5) [Town Meeting – Assign Warrant Article to Board Members](#)

VIII. CONTINUED BUSINESS

6) [NH Solar Garden – PILOT Agreement](#)

7) [Comcast Cable Franchise Renewal Agreement and Internet Update](#)

IX. TABLED BUSINESS

- Policies
 - III.1, III.3, III.5, III.7, IV.5
 - Personnel Policies – tabled 3/21/23 pending input from TA/Finance/HR
- Economic Development Committee Forum for Main St. pedestrian safety – crosswalks
- ARPA Funds Requests
 - Azaela Park – riverbank stabilization
 - Streetlights – rehabilitation
 - Community Center – front door replacement
 - Library – accessibility upgrade

- Community Park – signs and irrigation

X. PAST MEETING MINUTES

- 8) [Board of Selectmen Meeting Minutes February 6, 2024, 6:15 p.m.](#)
- 9) [Board of Selectmen Meeting Minutes February 9, 2024, 5:00 p.m.](#)
- 10) [Board of Selectmen Non-Public Meeting Minutes February 9, 2024, 5:01 p.m.](#)
- 11) [Board of Selectmen Public Hearing & Meeting Minutes February 13, 2024, 6:30 p.m.](#)

XI. COMMUNICATIONS

- 12) [Town Administrator Report](#)
- 13) [Correspondence - Letters and Notices](#)
- 14) [Department Reports](#)
- 15) Selectmen Reports

XII. PUBLIC COMMENT #2 (For any comment by any Henniker resident on a topic. Request time limit, up to 3 minutes)

XIII. NON-PUBLIC – If Necessary Non-public Session 91-A:3 II a, b, c, d, or e

XIV. ADJOURNMENT

XV. UPCOMING DATES 2024

- February 21 – Zoning Board of Adjustment Meeting @ 6:00 p.m. – CANCELLED
- February 27 – Solid Waste Disposal & Recycling Advisory Committee Meeting @ 5:15 p.m.
- February 27 – Police Facility Assessment Committee Meeting @ 6:00 p.m.
- February 27 – Concert Committee Meeting @ 6:30 p.m.
- March 5 – Board of Selectmen Meeting @ 6:15 p.m.
- March 12 – Town/School District Voting 7:00 a.m. to 7:00 p.m. Community School Gym
- March 16 – Town Meeting 1:00 p.m. Community School Gym

Please see the town website www.henniker.org and bulletin boards for meeting dates, times, locations, and agendas. ([Calendar: Public Meeting + Holiday | Henniker, NH](#))

Visitor Orientation to the Town Selectman's Meeting

Welcome to this evening's Selectmen's meeting. Please note that the purpose of the meeting is for the Selectmen to accomplish its work within a qualitative timeframe. Meetings are open to the public, but public participation is limited. If you wish to be heard by the board, please note the "Public Comment" at the beginning and end of the meeting to speak about items on a meeting agenda and/or matters pertaining to the business of the Selectmen. In addition, public hearings may be scheduled for public comment on specific matters. Speakers must be residents of the Town of Henniker, property owners in the town of Henniker, and/or designated representatives of recognized civic organizations or businesses located in the Town of Henniker. When they are at the podium, speakers first need to recite their name and address for the record. Visitors should address their comments to the board and not to any individual member. Each speaker shall be provided with a single opportunity for comment, limited to three (3) minutes. Public forum shall be limited to fifteen (15) minutes. Visitors should not expect a response to their comments or questions since the Board may not have discussed or taken a position on a matter. Public Comment is not a two-way dialogue between speaker(s), Selectmen, and/or the Town Administrator. The Chair will preserve strict order and decorum at all Board of Selectmen meetings. Outbursts from the public are not permitted.

ANNOUNCEMENTS



TOWN OF HENNIKER, NEW HAMPSHIRE
BOARD OF SELECTMEN & SEWER COMMISSIONERS
CONSENT AGENDA

Tuesday, February 20, 2024

Consent Agenda

- Item 1:** Abatement Application 23-002 – Map/Lot 5C-396-A, Ferreira
- Item 2:** Abatement Application 23-003 – Map/Lot 4-354-C, Ferreira
- Item 3:** 2023 Refund – Map/Lot 5C-396-A
- Item 4:** 2023 Refund – Map/Lot 4-354-C
- Item 5:** Land Use Change Tax Warrant & Bill – Map/Lot 11-649-A, Vitale
- Item 6:** Payroll Check Register – February 14, 2024
- Item 7:** Accounts Payable Manifest – February 21, 2024
- Item 8:** Volunteer Appointment – Emergency Management Director – Costello

Board of Selectmen Approval:

_____	_____
_____	_____

*Please note that the Consent Agenda is subject to change until 4:00 pm the day of a scheduled Selectmen's Meeting.

Received by
TOWN OF HENNIKER

JAN 29 2024

SELECTMEN'S OFFICE

FOR MUNICIPALITY USE ONLY:

Town File No.: 23-002

Taxpayer Name: Ferreira Properties LLC

TAXPAYER'S RSA 76:16 ABATEMENT APPLICATION TO MUNICIPALITY

SECTION A. Party(ies) Applying (Owner(s)/Taxpayer(s))

Name(s): Ignatius M Ferreira/Ferreira Properties LLC

Mailing Address: 396 Bacon Rd, Henniker NH 03242

Telephone Nos.: (Home) _____ (Cell) ██████████ (Work) _____ (Email) ██████████

Note: If an abatement is granted and taxes have been paid, interest on the abatement shall be paid in accordance with RSA 76:17-a. Any interest paid to the applicant must be reported by the municipality to the United States Internal Revenue Service, in accordance with federal law. Prior to the payment of an abatement with interest, the taxpayer shall provide the municipality with the applicant's social security number or federal tax identification number. Municipalities shall treat the social security or federal tax identification information as confidential and exempt from a public information request under RSA 91-A.

SECTION B. Party's(ies)' Representative if other than Person(s) Applying (Also Complete Section A)

Name(s): _____

Mailing Address: _____

Telephone Nos.: (Home) _____ (Cell) _____ (Work) _____ (Email) _____

SECTION C. Property(ies) for which Abatement is Sought

List the tax map and lot number, the actual street address and town of each property for which abatement is sought, a brief description of the parcel, and the assessment.

<u>Town Parcel ID#</u>	<u>Street Address/Town</u>	<u>Description</u>	<u>Assessment</u>
0005C Lot 396 Sub A	436 Western Ave	Apartments	\$733700

SECTION D. Other Property(ies)

List other property(ies) in the municipality owned in the same name(s), even if abatements for the other property(ies) have not been sought. The taxpayer's entire real property estate must be considered in determining whether the appealed property(ies) is (are) disproportionately assessed.

<u>Town Parcel ID#</u>	<u>Street Address/Town</u>	<u>Description</u>	<u>Assessment</u>
Map 4 Lot 354 Sub C1	396 Bacon Rd	Single Family	\$512448
Map 4 Lot 346 Sub X1	Freeman Colby	Vacant Land	\$3557
Map 4 Lot 354 Sub C	394 Bacon Rd	Mobile Home	\$205100

SECTION E. Reasons for Abatement Application

RSA 76:16 provides that an abatement may be granted for "good cause shown." "Good cause" generally means: 1) establishing an assessment is disproportionate to market value and the municipality's level of assessment; or 2) establishing poverty and inability to pay the tax. This form can be utilized for either basis of requesting an abatement. The taxpayer has the burden to prove good cause for an abatement.

- 1) If claiming disproportionality, state with specificity all the reasons supporting your application. Statements such as "taxes too high," "disproportionately assessed" or "assessment exceeds market value" are insufficient. Generally, specificity requires the taxpayer to present material on the following (all may not apply):
 1. physical data – incorrect description or measurement of property;
 2. market data – the property's market value on the April 1 assessment date, supported by comparable sales or a professional opinion of value; and/or
 3. level of assessment – the property's assessment is disproportionate by comparing the property's market value and the town-wide level of assessment.

Note: If you have an appraisal or other documentation, please submit it with this application.

- 2) If claiming poverty or inability to pay, state in detail why abatement of taxes is appropriate as opposed to some other relief such as relocating, refinancing or obtaining some alternative public assistance. Ansara v. City of Nashua, 118 N.H. 879 (1978).

(Attach additional sheets if needed.)

The December Tax bill shows an assessment of \$733,700. The property was inspected

by the appriaser and the tax card was updated to show an assessment of

\$684,200. Since the market is unchanged and the property has not been altered since

April 1 of 2023, I believe the FMV of this property was \$684,200 on 4/1/2023.

SECTION F. Taxpayer's(s') Opinion of Market Value

State your opinion of the market value of the property(ies) appealed as of April 1 of the year under appeal.

Town Parcel ID# Map 5C Lot 396 Sub A Appeal Year Market Value \$ 684,200

Town Parcel ID# _____ Appeal Year Market Value \$ _____

Explain the basis for your value opinion(s). (Attach additional sheets if necessary.)

I'm basing my opinion of value on that of the appraiser hired by the town
to review and update properties in Henniker. The property was unchanged
since March of 2020 when several tenants caused damage
during covid and vacated the premises.

SECTION G. Sales, Rental and/or Assessment Comparisons

List the properties you are relying upon to show overassessment of your property(ies). If you are appealing an income producing property, list the comparable rental properties and their rents. (Attach additional sheets if needed.)

Town Parcel ID#	Street Address	Sale Price/Date of Sale	Rents	Assessment

SECTION H. Certification by Party(ies) Applying

Pursuant to BTLA Tax 203.02(d), the applicant(s) **MUST** sign the application. By signing below, the Party(ies) applying certifies (certify) and swear(s) und _____ and the facts stated are true to the best of my _____

Date: 01/17/2024

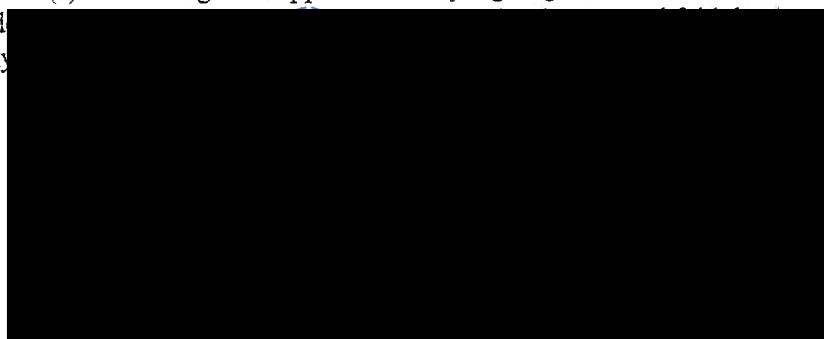

(Signature)

(Print Name)

SECTION I. Certification and Appearance by Representative (If Other Than Party(ies) Applying)

By signing below, the representative of the Party(ies) applying certifies and swears under penalties of RSA 641:3:

1. all certifications in Section H are true;
2. the Party(ies) applying has (have) authorized this representation and has (have) signed this application; and
3. a copy of this form was sent to the Party(ies) applying.

Date: _____
_____ (Representative's Signature) _____ (Print Name)

SECTION J. Disposition of Application* (For Use by Selectmen/Assessor)

*RSA 76:16, II states: the municipality "shall review the application and shall grant or deny the application in writing by July 1 after notice of tax date"

Abatement Request: GRANTED _____ Revised Assessment: \$ 684,200 DENIED _____

Remarks:

Date: _____

(Selectmen/Assessor Signature)

(Selectmen/Assessor Signature)

(Selectmen/Assessor Signature)

(Selectmen/Assessor Signature)

Town of Henniker
 18 Depot Hill Rd
 Henniker, NH 03242
 Temp - Return Service Requested

FERREIRA PROPERTIES LLC
 21 HAMPTON ROAD STE 101
 EXETER, NH 03833

RECEIVED
 DEC 6 2023
 TOWN CLERK/TAX COLLECTOR
 HENNIKER
 2023 HENNIKER PROPERTY TAX - BILL 2 OF 2

Invoice: 2023P02008706
 Billing Date: 11/08/2023
 Payment Due Date: 12/12/2023
 Amount Due: \$ 8,560.00

8% APR Charged After 12/12/2023

Property Owner		Assessments	
Owner: FERREIRA PROPERTIES LLC			
Tax Rates		Taxable Land:	154,700
County:	\$ 1.68	Buildings:	579,000
School:	\$ 12.50	Total:	733,700
Town:	\$ 6.93		
State Education:	\$ 1.27		

Property Description		
Map: 00005C	Lot: 000396	Sub: 00000A
Location: 436 WESTERN AVE Acres: 1.750		
Summary Of Taxes		
Total Tax:		\$ 16,420.00
- First Bill:		\$ 7,860.00
- Abated/Paid:		\$ 0.00
- Veteran Credits:		\$ 0.00

Amount Due By 12/12/2023: **\$ 8,560.00**

15312

Total Tax Rate:	\$ 22.38	Net Value:	733,700
-----------------	----------	------------	---------

OWNER INFORMATION		SALES HISTORY					PICTURE		
FERREIRA PROPERTIES LLC 21 HAMPTON ROAD STE 101 EXETER, NH 03833		Date 09/07/2018 07/26/2018 11/18/2008 11/01/1991	Book 3607 3602 3096 1868	Page 1029 1109 1608 1143	Type U 1 38 Q I Q I Q I	Price 1 FERRIERA PROPERTIES LLC 400,000 390,000 210,000	Grantor 436 WESTERN AVE STEINBACH KEVIN E		
LISTING HISTORY		NOTES							
10/26/23 RWCL 07/07/23 RWVM 01/01/23 INSP MARKED FOR INSPECTION 03/29/22 ERPR 03/04/21 RD01 MEASUR+1VISIT 09/29/20 SW41 HEARING CHANGE 07/31/20 VS14 FIELD REVIEW 12/08/19 SW15 SALE REVIEW	WHITE APTS TOTAL 7 UNITS, BOTH BLDGS 4 UNITS THIS BLDG 3-2 BR/1-3 BR #78 ON THE STRUCTURE FUN=INC 2018 = PROP SALE \$400,000 20: UNITS ALL VACANT, BEING REHABED 9/20 REVIEW "UC" TO SEE IF WORK IS DONE 21: FUS CARD #1 =UNOCC, BAS APPEARS OCC; 3/22 INT OVERALL COMPL, RENTED, 3 JUST FINISHED BUT NOT RENTED YET; REMOVED UC; 7/23; NOH; EXT GD FOR AGE; SIDING NDS WASH; PU OPF'S UNDER UFF DEK; 10/23; BOTH UFF APTS NOT RENTABLE; BOTH MISSING VARIED AMTS OF FLRING; BTHS & KITS RMVD TO DO FLRS; CK 24;								
EXTRA FEATURES VALUATION								MUNICIPAL SOFTWARE BY AVIFAR	
Feature Type PAVING	Units 5,000	Lngh x Width 5000 x 1	Size Adj 63	Rate 3.25	Cond 50	Market Value 5,119	Notes Year: 1996	HENNIKER ASSESSING OFFICE	
						5,100			
PARCEL TOTAL TAXABLE VALUE									
Year 2022	Building \$ 570,700	Features \$ 7,800	Land \$ 160,000			Parcel Total: \$ 738,500			
Year 2023	Building \$ 253,500	Features \$ 5,100	Land \$ 154,700 (e)			Parcel Total: \$ 684,200			
(Card Total: \$ 413,300)									

LAND VALUATION													LAST REVALUATION: 2022	
Zone: VILLAGE PROPER WS Minimum Acreage: 0.46 Minimum Frontage: 100											Site: AVERAGE Driveway: PAVED Road: PAVED			
Land Type COM/IND COM/IND	Units 0.460 ac 1.290 ac 1.750 ac	Base Rate 95,000 x 2,500	NC F X	Adj 110 100	Site 100	Road 100	DWay 100	Topography 100 -- LEVEL 100 -- LEVEL	Cond 145 100	Ad Valorem 151,500 3,200 154,700	SPI R 0 N 0 N	Tax Value 151,500 3,200 154,700	Notes USE/FP/7UNTS/4 BLD	

PICTURE	OWNER	TAXABLE DISTRICTS	BUILDING DETAILS						
	<p>FERREIRA PROPERTIES LLC 21 HAMPTON ROAD STE 101 EXETER, NH 03833</p>	<table border="1"> <thead> <tr> <th>District</th> <th>Percentage</th> </tr> </thead> <tbody> <tr> <td> </td> <td> </td> </tr> </tbody> </table>	District	Percentage			<p>Model: 2.00 STORY MULTI FAM Roof: GABLE OR HIP/ASPHALT Ext: VINYL SIDING Int: DRYWALL Floor: CARPET/LINOLEUM OR SIM Heat: GAS/FA NO DUCTS</p> <p>Bedrooms: 7 Baths: 4.0 Fixtures: Extra Kitchens: 3 Fireplaces: A/C: No Generators:</p> <p>Quality: A0 AVG</p> <p>Com. Wall: Size Adj: 0.9022 Base Rate: CMF 136.00 Bldg. Rate: 0.9014 Sq. Foot Cost: \$ 122.59</p>		
District	Percentage								
PERMITS									
<table border="1"> <thead> <tr> <th>Date</th> <th>Project Type</th> <th>Notes</th> </tr> </thead> <tbody> <tr> <td> </td> <td> </td> <td> </td> </tr> </tbody> </table>				Date	Project Type	Notes			
Date	Project Type	Notes							

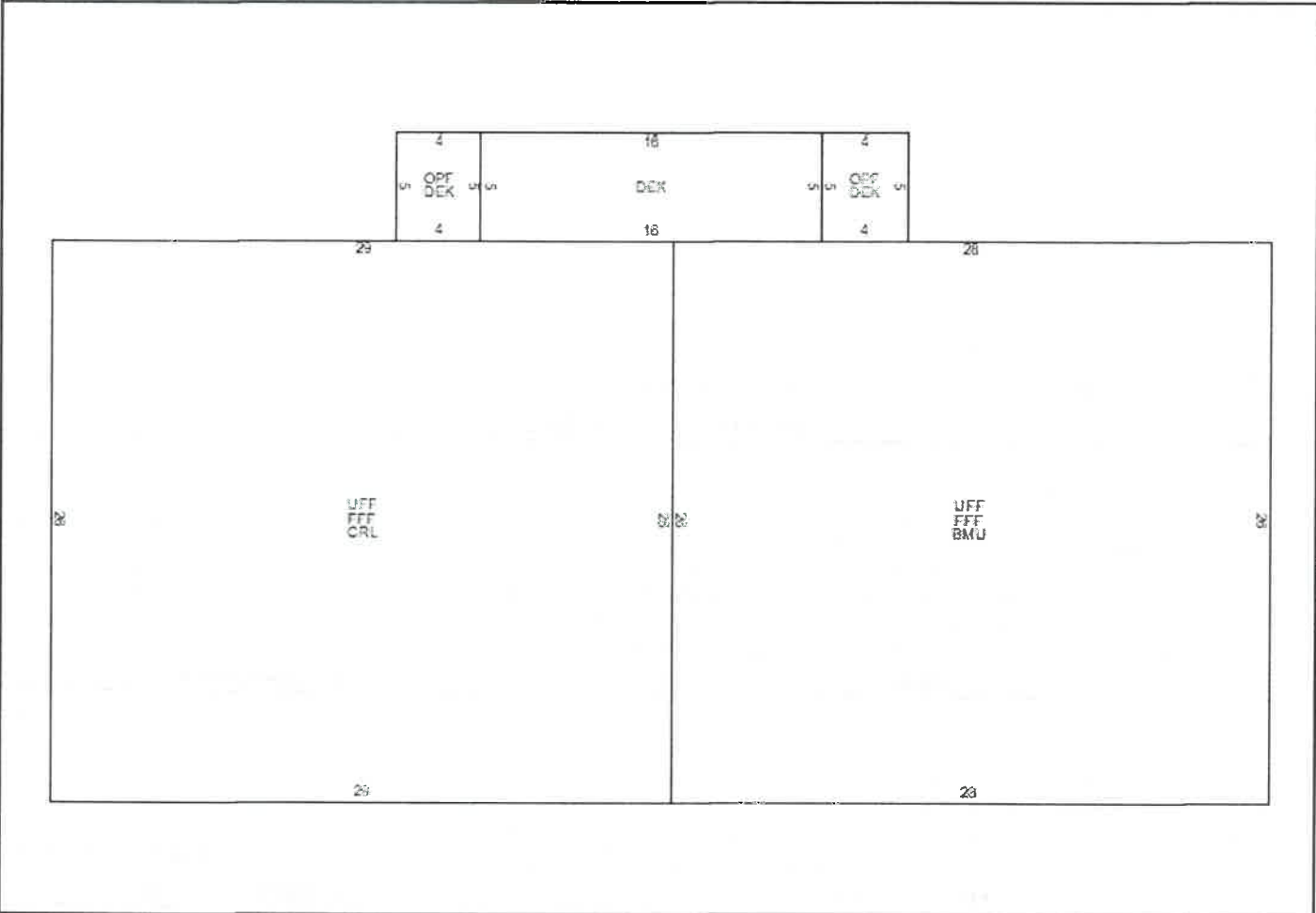

BUILDING SUB AREA DETAILS				
ID	Description	Area	Adj.	Effect.
UFF	UPPER FLR FIN	1482	1.00	1482
DEK	DECK/ENTRANCE	120	0.10	12
FFF	FST FLR FIN	1482	1.00	1482
CRL	CRAWL SPACE	754	0.05	38
BMU	BSMNT	728	0.15	109
OPF	OPEN PORCH	40	0.25	10
GLA:	2,964	4,606		3,133

2022 BASE YEAR BUILDING VALUATION		
Market Cost New:		\$ 384,074
Year Built:		1960
Condition For Age:	GOOD	24 %
Physical:		
Functional:		
Economic:		
Temporary:	UFF	10 %
Total Depreciation:		34 %
Building Value:		\$ 253,500

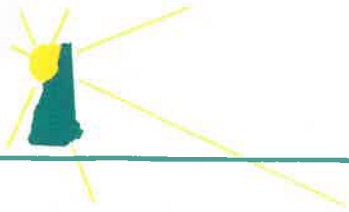

Avitar Associates of New England, Inc.

A Municipal Services Company

Received by
TOWN OF HENNIKER

FEB 05 2024

SELECTMEN'S OFFICE

February 1, 2024

**Town of Henniker
Helga Winn
Board of Selectmen
18 Depot Hill Road
Henniker, NH 03242**

**Re: Abatement Recommendations – Ferreira Properties LLC (436 Western Avenue)
Ferreira Family Trust (394 Bacon Road)**

Dear Helga & Board Members:

Attached are my recommendations for the above-referenced abatement requests.

As always, should you have questions or concerns, please do not hesitate to contact me.

Sincerely,

**Evan Robitge
Assessor Supervisor**

ER/sjc
Enclosures

Abatement Recommendation

Map 5C, Lot 396 Sub A

436 Western Ave

Ferreira Properties LLC

The taxpayer has filed for abatement on this 1.75-acre improved parcel with a 2.00 story multi-family style dwelling and 3 additional ranch/cottage style dwellings assessed at \$733,700. As basis for the abatement, the taxpayer states the property was visited by an Avitar Data Collector on October 26, 2023, where data corrections were made, reducing the value, but it was not accounted for until after the final issue tax bill. The taxpayer is correct, due to the timing of the callback process and final issue tax bill, the corrections were not made in the database until after the final issue tax bills were generated. The corrections to account for the interior work needed, on-going renovation, condition, etc. reduced the assessment from \$733,700 to \$684,200 and therefore, I recommend an abatement on the \$49,500 value difference, an abatement of \$1,108, plus statutory interest ($\$49,500 / \$1,000 \times \$22.38$ 2023 Tax Rate). Please note, the property will be flagged and reviewed for TY2024 to determine the progress to the work that needed to be complete, and the value will be changed accordingly at that point.

Received by
TOWN OF HENNIKER

FEB 05 2024

SELECTMEN'S OFFICE

Received by
TOWN OF HENNIKER

JAN 29 2024

SELECTMEN'S OFFICE

FOR MUNICIPALITY USE ONLY:

Town File No.: 23-003

Taxpayer Name: Ferreira
Family Trust

TAXPAYER'S RSA 76:16 ABATEMENT APPLICATION TO MUNICIPALITY

SECTION A. Party(ies) Applying (Owner(s)/Taxpayer(s))

Name(s): Ignatius M Ferreira/Ferreira Family Trust

Mailing Address: 396 Bacon Rd, Henniker NH 03242

Telephone Nos.: (Home) _____ (Cell) _____ (Work) _____ (Email) _____

Note: If an abatement is granted and taxes have been paid, interest on the abatement shall be paid in accordance with RSA 76:17-a. Any interest paid to the applicant must be reported by the municipality to the United States Internal Revenue Service, in accordance with federal law. Prior to the payment of an abatement with interest, the taxpayer shall provide the municipality with the applicant's social security number or federal tax identification number. Municipalities shall treat the social security or federal tax identification information as confidential and exempt from a public information request under RSA 91-A.

SECTION B. Party's(ies)' Representative if other than Person(s) Applying (Also Complete Section A)

Name(s): _____

Mailing Address: _____

Telephone Nos.: (Home) _____ (Cell) _____ (Work) _____ (Email) _____

SECTION C. Property(ies) for which Abatement is Sought

List the tax map and lot number, the actual street address and town of each property for which abatement is sought, a brief description of the parcel, and the assessment.

<u>Town Parcel ID#</u>	<u>Street Address/Town</u>	<u>Description</u>	<u>Assessment</u>
Map 4 Lot 354 Sub C	394 Bacon Rd	Mobile Home	\$205100

SECTION D. Other Property(ies)

List other property(ies) in the municipality owned in the same name(s), even if abatements for the other property(ies) have not been sought. The taxpayer's entire real property estate must be considered in determining whether the appealed property(ies) is (are) disproportionately assessed.

<u>Town Parcel ID#</u>	<u>Street Address/Town</u>	<u>Description</u>	<u>Assessment</u>
Map 4 Lot 354 Sub C1	396 Bacon Rd	Single Family	\$512448
Map 4 Lot 346 Sub X1	Freeman Colby	Vacant Land	\$3557
Map 5C Lot 396 Sub A	436 Western Ave	Apartments	\$733,700

SECTION E. Reasons for Abatement Application

RSA 76:16 provides that an abatement may be granted for "good cause shown." "Good cause" generally means: 1) establishing an assessment is disproportionate to market value and the municipality's level of assessment; or 2) establishing poverty and inability to pay the tax. This form can be utilized for either basis of requesting an abatement. The taxpayer has the burden to prove good cause for an abatement.

- 1) If claiming disproportionality, state with specificity all the reasons supporting your application. Statements such as "taxes too high," "disproportionately assessed" or "assessment exceeds market value" are insufficient. Generally, specificity requires the taxpayer to present material on the following (all may not apply):
 1. physical data – incorrect description or measurement of property;
 2. market data – the property's market value on the April 1 assessment date, supported by comparable sales or a professional opinion of value; and/or
 3. level of assessment – the property's assessment is disproportionate by comparing the property's market value and the town-wide level of assessment.

Note: If you have an appraisal or other documentation, please submit it with this application.

- 2) If claiming poverty or inability to pay, state in detail why abatement of taxes is appropriate as opposed to some other relief such as relocating, refinancing or obtaining some alternative public assistance. Ansara v. City of Nashua, 118 N.H. 879 (1978).

(Attach additional sheets if needed.)

The December Tax bill shows an assessment of \$205,100. The property was inspected

by the town appriaser and the tax card was updated to show an assessment of

\$174,500. Since the market is unchanged and the property has not been altered since

April 1 of 2023, I believe the FMV of this property was \$174,500 on 4/1/2023.

SECTION F. Taxpayer's(s') Opinion of Market Value

State your opinion of the market value of the property(ies) appealed as of April 1 of the year under appeal.

Town Parcel ID# Map 4 Lot 354 Sub C Appeal Year Market Value \$ 174,500

Town Parcel ID# _____ Appeal Year Market Value \$ _____

Explain the basis for your value opinion(s). (Attach additional sheets if necessary.)

I'm basing my opinion of value on that of the appraiser hired by the town
to review and update properties in Henniker. The property was unchanged
since January of 2023. Since there has been no big decline in market
price for land since the begining of the year the FMV price should not have changed.

SECTION G. Sales, Rental and/or Assessment Comparisons

List the properties you are relying upon to show overassessment of your property(ies). If you are appealing an income producing property, list the comparable rental properties and their rents. (Attach additional sheets if needed.)

Town Parcel ID#	Street Address	Sale Price/Date of Sale	Rents	Assessment

SECTION H. Certification by Party(ies) Applying

Pursuant to BTLA Tax 203.02(d), the applicant(s) **MUST** sign the application. By signing below, the Party(ies) applying certifies (certify) and swear(s) under the penalties of RSA 641:3 the application has a good faith basis and the facts stated are true to the best of m

Date: 01/17/2024

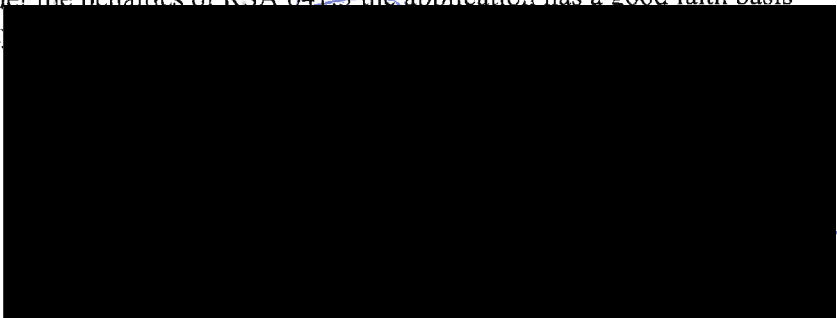

(Signature)

(Print Name)

SECTION I. Certification and Appearance by Representative (If Other Than Party(ies) Applying)

By signing below, the representative of the Party(ies) applying certifies and swears under penalties of RSA 641:3:

1. all certifications in Section H are true;
2. the Party(ies) applying has (have) authorized this representation and has (have) signed this application;
and
3. a copy of this form was sent to the Party(ies) applying.

Date: _____
_____ (Representative's Signature) _____ (Print Name)

SECTION J. Disposition of Application* (For Use by Selectmen/Assessor)

*RSA 76:16, II states: the municipality "shall review the application and shall grant or deny the application in writing by July 1 after notice of tax date"

Abatement Request: GRANTED _____ Revised Assessment: \$ 174,500 DENIED _____

Remarks:

Date: _____

(Selectmen/Assessor Signature)

(Selectmen/Assessor Signature)

(Selectmen/Assessor Signature)

(Selectmen/Assessor Signature)

Town of Henniker
 18 Depot Hill Rd
 Henniker, NH 03242
 Temp - Return Service Requested

RECEIVED
 NOV 21 2023
 TOWN CLK/TAX COLLECTOR
 HENNIKER, NH

FERREIRA FAMILY TRUST
 FERREIRA IGNATIUS M TRUSTEE
 394 BACON ROAD
 HENNIKER, NH 03242-6082

2023 HENNIKER PROPERTY TAX - BILL 2 OF 2

Invoice: 2023P02008704
 Billing Date: 11/08/2023
 Payment Due Date: 12/12/2023
 Amount Due: \$ 2,391.00

8% APR Charged After 12/12/2023

Property Owner				Property Description			
Owner: FERREIRA FAMILY TRUST FERREIRA IGNATIUS M TRUSTEE				Map: 000004	Lot: 000354	Sub: 00000C	
				Location: 394 BACON RD Acres: 42.500			
Tax Rates		Assessments		Summary Of Taxes			
County:	\$ 1.68	Taxable Land:	116,100	Total Tax:		\$ 4,590.00	
School:	\$ 12.50	Buildings:	89,000	- First Bill:		\$ 2,199.00	
Town:	\$ 6.93	Total:	205,100	- Abated/Paid:		\$ 0.00	
State Education:	\$ 1.27			- Veteran Credits:		\$ 0.00	
Taxable Land Includes Current Use				Amount Due By 12/12/2023: \$ 2,391.00			
Total Tax Rate: \$ 22.38		Net Value: 205,100					

OWNER INFORMATION
FERREIRA FAMILY TRUST FERREIRA IGNATIUS M TRUSTEE 394 BACON ROAD HENNIKER, NH 03242-6082

SALES HISTORY					
Date	Book	Page	Type	Price	Grantor
05/07/2015	3476	2586	U I 44	1	FERREIRA IGNATIUS
01/29/2014	3429	0793	U I 37	78,933	CITIMORTGAGE INC
09/19/2013	3411	0569	U I 51	68,400	TALBOT RONALD

PICTURE

LISTING HISTORY		
01/01/24	INSP	MARKED FOR INSPECTION
10/27/23	RWCL	
06/14/21	RD07	MEASUR/ INFO TAKEN AT DOO
08/06/20	SS14	FIELD REVIEW
06/19/18	BL14	FIELD REVIEW
04/25/18	BL14	FIELD REVIEW
08/03/17	GH98	ASSESSOR REVIEW
08/04/16	GH98	ASSESSOR REVIEW

NOTES
BEIGE IA, CLASS V ROAD 03: LOT SIZE TO 42.5 A DUE TO 2 SUBDIV DRIVEWAY ESMNT ACROSS LOT FOR 354C1 SHARED DRIVE; 16: UPDATED OB INVENTORY, CORRECTED 16X20 SHED TO GAR W LOFT, SHOP & GAR ATTACHED 17: REPORTED SHEDS & ALL OUTBUILDINGS REMOVED ON INVENTORY - 8/3/17 ALL 21: NO LOFT IN FGR=PDS; 10/23; INT COND PR; KIT RMVD; FLRING RUINED-STRONG ANIMAL ODOR; CPT RMVD; RMVD STO CONTS-PU'D AS SHEDS-NV; SHOP DEMO'D; CK 24 FOR MH RMVL & NEW MTL GAR;

EXTRA FEATURES VALUATION							
Feature Type	Units	Length x Width	Size Adj	Rate	Cond	Market Value	Notes
GARAGE-1 STY/ATTIC	320	20 x 16	110	33.00	30	3,485	Year: 2005
						3,500	

MUNICIPAL SOFTWARE BY AVITAR

HENNIKER ASSESSING OFFICE

PARCEL TOTAL TAXABLE VALUE			
Year	Building	Features	Land
2022	\$ 80,800	\$ 8,200	\$ 116,097
			Parcel Total: \$ 205,097
2023	\$ 54,900	\$ 3,500	\$ 116,100
			Parcel Total: \$ 174,500

LAND VALUATION											LAST REVALUATION: 2023			
Zone: RES NEIGHBORHOOD Minimum Acreage: 2.00 Minimum Frontage: 200											Site: AVERAGE Driveway: GRAVEL/DIRT Road: PAVED			
Land Type	Units	Base Rate	NC	Adj	Site	Road	DWay	Topography	Cond	Ad Valorem	SPI	R	Tax Value	Notes
IF RES	2.000 ac	127,000	E	100	100	100	95	95 -- MILD	95	108,900	0	N	108,900	SHARED DRIVEWAY
IF RES	2.000 ac	x 2,500	X	85				90 -- ROLLING	100	3,800	0	N	3,800	
UNMNGD PINE	20.000 ac	x 2,500	X	85				90 -- ROLLING	100	38,300	65	Y	2,615	
UNMNGD OTHER	18.500 ac	x 2,500	X	85				85 -- MODERATE	100	33,400	65	Y	785	
										42.500 ac			184,400	116,100

HENNIKER, NH 03242-6082

100% MIN PLWD



PERMITS

Date	Project Type	Notes

Heat: **WOOD/COAL/CONVECTION**
 Bedrooms: 3 Baths: 1.0 Fixtures: 3
 Extra Kitchens: Fireplaces:
 A/C: No Generators:
 Quality: **A0 AVG**
 Com. Wall:
 Size Adj: **0.7897** Base Rate: **MHS 115.00**
 Bldg. Rate: **0.6555**
 Sq. Foot Cost: **\$ 75.38**

BUILDING SUB AREA DETAILS

ID	Description	Area	Adj.	Effect.
FFF	FST FLR FIN	1779	1.00	1779
SLB	SLB	1599	0.00	0
BMU	BSMNT	180	0.15	27
STO	STORAGE AREA	46	0.25	12
DEK	DECK/ENTRANCE	16	0.10	2
GLA:	1,779	3,620		1,820

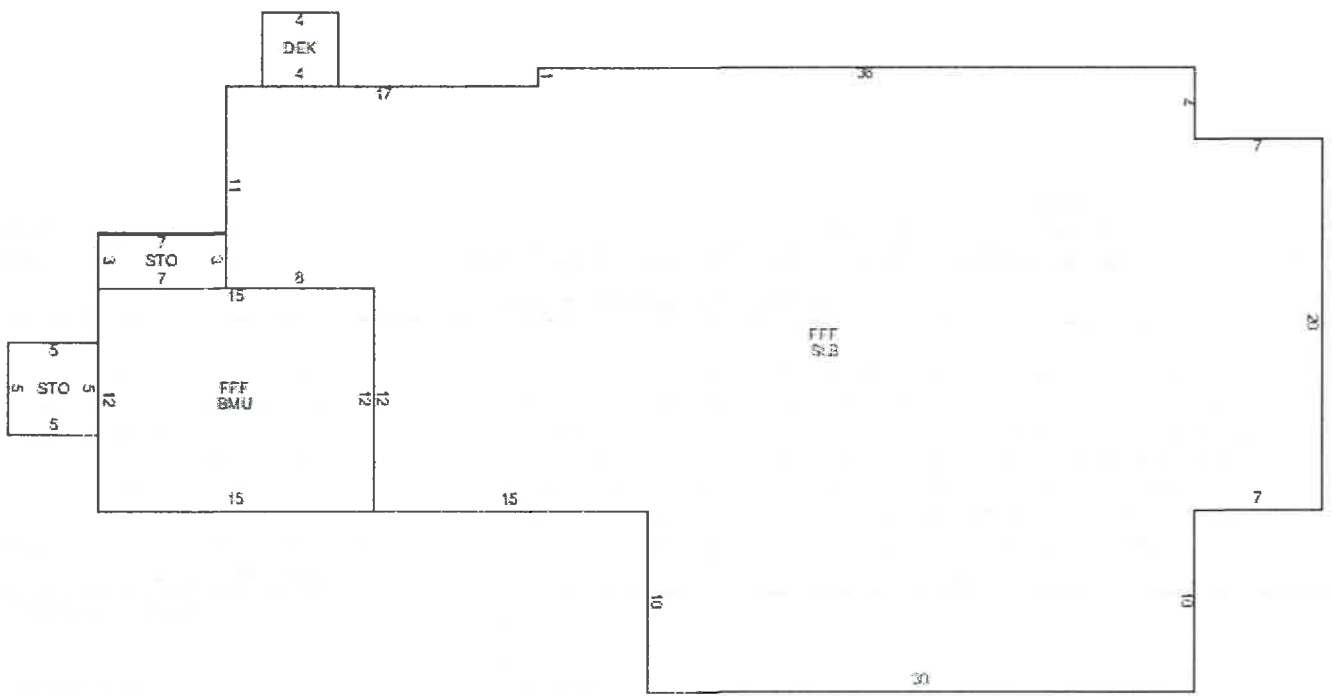

2022 BASE YEAR BUILDING VALUATION

Market Cost New: **\$ 137,192**
 Year Built: **1976**
 Condition For Age: **FAIR 60 %**
 Physical:
 Functional:
 Economic:
 Temporary:
 Total Depreciation: **60 %**
 Building Value: **\$ 54,900**

Avitar Associates of New England, Inc.

A Municipal Services Company

Received by
TOWN OF HENNIKER

FEB 05 2024

SELECTMEN'S OFFICE

February 1, 2024

**Town of Henniker
Helga Winn
Board of Selectmen
18 Depot Hill Road
Henniker, NH 03242**

**Re: Abatement Recommendations – Ferreira Properties LLC (436 Western Avenue)
Ferreira Family Trust (394 Bacon Road)**

Dear Helga & Board Members:

Attached are my recommendations for the above-referenced abatement requests.

As always, should you have questions or concerns, please do not hesitate to contact me.

Sincerely



**Evan Roberge
Assessor Supervisor**

ER/sjc
Enclosures

Abatement Recommendation

Map 4, Lot 354 Sub C

394 Bacon Road

Ferreira Family Trust

The taxpayer has filed for abatement on this 42.5-acre (38.5-acres in current use) improved parcel with a 1.00 story manufactured home assessed at \$205,100. As basis for the abatement, the taxpayer states the property was visited by an Avitar Data Collector on October 27, 2023, where data corrections were made, reducing the value, but it was not accounted for until after the final issue tax bill. The taxpayer is correct, due to the timing of the callback process and final issue tax bill, the corrections were not made in the database until after the final issue tax bills were generated. The corrections to account for the interior work needed, overall condition, kitchen removed, outbuildings demolished, etc. reduced the assessment from \$205,100 to \$174,500 and therefore, I recommend an abatement on the \$30,600 value difference, an abatement of \$685, plus statutory interest ($\$30,600 / \$1,000 \times \$22.38$ 2023 Tax Rate). Please note, the property will be flagged and reviewed for TY2024 to determine the progress to the work that needed to be complete, and the value will be changed accordingly at that point.

Received by
TOWN OF HENNIKER
FEB 05 2024
SELECTMEN'S OFFICE



TOWN OF HENNIKER, NEW HAMPSHIRE

February 6, 2024

2023 ABATEMENT / REFUND

To the Collector of Taxes:

By vote of the Board of Selectmen upon application of:

Ferreira Properties, LLC

Lot Number: 5C-396-A / 436 Western Ave.
Mailing Address: 396 Bacon Road
Henniker, NH 03242

2023 Old assessment: \$733,700
2023 Revised assessment: \$684,200

Abated amount of assessed value: \$ 49,500

Abated tax amount for 2023: \$1,108.00 + interest

Board of Selectmen:

Selectmen's Office
*Administration, Finance,
Assessing, Planning,
Zoning & Building Permits*
18 Depot Hill Rd.
Henniker NH 03242
Ph (603) 428-3221
Fx (603) 428-4366

Town Clerk / Tax Collector
18 Depot Hill Rd.
Henniker NH 03242
Ph (603) 428-3240
Fx (603) 428-4366

**Transfer / Recycling Center
Parks and Properties**
18 Depot Hill Rd.
Henniker NH 03242
Physical: 1393 Weare Rd.
Ph (603) 428-7604

Cogswell Spring Water Works
146 Davison Rd.
Henniker NH 03242
Ph (603) 428-3237
Fx (603) 428-3362

Wastewater Treatment Plant
18 Depot Hill Rd.
Henniker NH 03242
Ph (603) 428-7215
Fx (603) 428-8312
Physical: 199 Ramsdell Rd.

Highway
18 Depot Hill Rd.
Henniker NH 03242
Physical: 209 Ramsdell Rd.
Ph (603) 428-7200
Fx (603) 428-7200

Police
340 Western Ave.
Henniker NH 03242
Ph (603) 428-3213
(Dial 911 for an Emergency)
Fx (603) 428-7509

Fire & Rescue
216 Maple St.
Henniker NH 03242
Ph (603) 428-7552
(Dial 911 for an Emergency)
Fx (603) 428-7628

Avitar Associates of New England, Inc.

A Municipal Services Company

Received by
TOWN OF HENNIKER

FEB 05 2024

SELECTMEN'S OFFICE

February 1, 2024

**Town of Henniker
Helga Winn
Board of Selectmen
18 Depot Hill Road
Henniker, NH 03242**

**Re: Abatement Recommendations – Ferreira Properties LLC (436 Western Avenue)
Ferreira Family Trust (394 Bacon Road)**

Dear Helga & Board Members:

Attached are my recommendations for the above-referenced abatement requests.

As always, should you have questions or concerns, please do not hesitate to contact me.

Sincerely,



**Evan Roberge
Assessor Supervisor**

ER/sjc
Enclosures

Abatement Recommendation

Map 5C, Lot 396 Sub A

436 Western Ave

Ferreira Properties LLC

The taxpayer has filed for abatement on this 1.75-acre improved parcel with a 2.00 story multi-family style dwelling and 3 additional ranch/cottage style dwellings assessed at \$733,700. As basis for the abatement, the taxpayer states the property was visited by an Avitar Data Collector on October 26, 2023, where data corrections were made, reducing the value, but it was not accounted for until after the final issue tax bill. The taxpayer is correct, due to the timing of the callback process and final issue tax bill, the corrections were not made in the database until after the final issue tax bills were generated. The corrections to account for the interior work needed, on-going renovation, condition, etc. reduced the assessment from \$733,700 to \$684,200 and therefore, I recommend an abatement on the \$49,500 value difference, an abatement of \$1,108, plus statutory interest ($\$49,500 / \$1,000 \times \$22.38$ 2023 Tax Rate). Please note, the property will be flagged and reviewed for TY2024 to determine the progress to the work that needed to be complete, and the value will be changed accordingly at that point.

Received by
TOWN OF HENNIKER

FEB 05 2024

SELECTMEN'S OFFICE



TOWN OF HENNIKER, NEW HAMPSHIRE

February 6, 2024

2023 ABATEMENT / REFUND

To the Collector of Taxes:

By vote of the Board of Selectmen upon application of:

Ferreira Family Trust

Lot Number: 4-354-C / 394 Bacon Road

Mailing Address: 396 Bacon Road
Henniker, NH 03242

2023 Old assessment:	\$205,100
2023 Revised assessment:	\$174,500

Abated amount of assessed value: \$ 30,600

Abated tax amount for 2023: \$ 685.00 + interest

Board of Selectmen:

_____	_____
_____	_____
_____	_____

Selectmen's Office
*Administration, Finance,
Assessing, Planning,
Zoning & Building Permits*
18 Depot Hill Rd.
Henniker NH 03242
Ph (603) 428-3221
Fx (603) 428-4366

Town Clerk / Tax Collector
18 Depot Hill Rd.
Henniker NH 03242
Ph (603) 428-3240
Fx (603) 428-4366

**Transfer / Recycling Center
Parks and Properties**
18 Depot Hill Rd.
Henniker NH 03242
Physical: 1393 Weare Rd.
Ph (603) 428-7604

Cogswell Spring Water Works
146 Davison Rd.
Henniker NH 03242
Ph (603) 428-3237
Fx (603) 428-3362

Wastewater Treatment Plant
18 Depot Hill Rd.
Henniker NH 03242
Ph (603) 428-7215
Fx (603) 428-8312
Physical: 199 Ramsdell Rd.

Highway
18 Depot Hill Rd.
Henniker NH 03242
Physical: 209 Ramsdell Rd.
Ph (603) 428-7200
Fx (603) 428-7200

Police
340 Western Ave.
Henniker NH 03242
Ph (603) 428-3213
(Dial 911 for an Emergency)
Fx (603) 428-7509

Fire & Rescue
216 Maple St.
Henniker NH 03242
Ph (603) 428-7552
(Dial 911 for an Emergency)
Fx (603) 428-7628

Avitar Associates of New England, Inc.

A Municipal Services Company

Received by
TOWN OF HENNIKER

FEB 05 2024

SELECTMEN'S OFFICE

February 1, 2024

**Town of Henniker
Helga Winn
Board of Selectmen
18 Depot Hill Road
Henniker, NH 03242**

**Re: Abatement Recommendations – Ferreira Properties LLC (436 Western Avenue)
Ferreira Family Trust (394 Bacon Road)**

Dear Helga & Board Members:

Attached are my recommendations for the above-referenced abatement requests.

As always, should you have questions or concerns, please do not hesitate to contact me.

Sincerely,



Assessor Supervisor

ER/sjc
Enclosures

Abatement Recommendation

Map 4, Lot 354 Sub C

394 Bacon Road

Ferreira Family Trust

The taxpayer has filed for abatement on this 42.5-acre (38.5-acres in current use) improved parcel with a 1.00 story manufactured home assessed at \$205,100. As basis for the abatement, the taxpayer states the property was visited by an Avitar Data Collector on October 27, 2023, where data corrections were made, reducing the value, but it was not accounted for until after the final issue tax bill. The taxpayer is correct, due to the timing of the callback process and final issue tax bill, the corrections were not made in the database until after the final issue tax bills were generated. The corrections to account for the interior work needed, overall condition, kitchen removed, outbuildings demolished, etc. reduced the assessment from \$205,100 to \$174,500 and therefore, I recommend an abatement on the \$30,600 value difference, an abatement of \$685, plus statutory interest ($\$30,600 / \$1,000 \times \$22.38$ 2023 Tax Rate). Please note, the property will be flagged and reviewed for TY2024 to determine the progress to the work that needed to be complete, and the value will be changed accordingly at that point.

Received by
TOWN OF HENRIKED
FEB 05 2024
SELECTMEN'S OFFICE

FORM
A-5W

**NEW HAMPSHIRE DEPARTMENT OF REVENUE ADMINISTRATION
WARRANT FOR LAND USE CHANGE TAX**

STEP 1 - TAX COLLECTOR'S WARRANT FOR LAND USE CHANGE TAX IN THE MUNICIPALITY OF:

NAME OF MUNICIPALITY TOWN OF HENNIKER		
STREET ADDRESS 18 DEPOT HILL ROAD		
MAILING ADDRESS 18 DEPOT HILL ROAD		
MUNICIPALITY HENNIKER	STATE NH	ZIP CODE 03242

STEP 2 - COLLECTION OF LAND USE CHANGE TAX

(a) State of New Hampshire, County of: MERRIMACK	
(b) To: DEBORAH C. AUCOIN	Municipal Collector of taxes
(c) for the municipality of: TOWN OF HENNIKER	in said County.
(d) In the name of said State you are directed to collect the LAND USE CHANGE TAX in the list herewith committed to you, amounting in all of the sum of:	\$ 700.00
Interest at 18% will be assessed after 30 days.	
(e) Given under our hands at HENNIKER, NH	
(f) This day of FEBRUARY 20, 2024	
(g) LANDOWNER NAME OR RIGHT -OF- WAY RESPONSIBLE PARTY VITALE, FRANK & AUDREY	
LANDOWNER NAME OR RIGHT -OF- WAY RESPONSIBLE PARTY MAILING ADDRESS 896 CRANEY HILL ROAD, HENNIKER, NH 03242	
(h) MUNICIPAL TAX MAP 11	LOT NUMBER 649-A

STEP 3 - SIGNATURES OF A MAJORITY OF THE MUNICIPAL ASSESSING OFFICIALS

TYPE OR PRINT NAME (in black or dark blue ink)	SIGNATURE (in black or dark blue ink)	DATE
KRIS BLOMBACK		02/20/2024
BILL MARKO		02/20/2024
D. SCOTT OSGOOD		02/20/2024
NEAL MARTIN		02/20/2024
JEFF MORSE		02/20/2024

FORM
A-5W

NEW HAMPSHIRE DEPARTMENT OF REVENUE ADMINISTRATION

WARRANT FOR LAND USE CHANGE TAX

INSTRUCTIONS

WHEN TO FILE

The Municipal Assessing Officials, upon their approval of a Form A-5, Municipality Land Use Change Tax Bill, shall concurrently approve and sign the Form A-5W, Warrant For Land Use Change Tax.

WHO MUST FILE

The Municipal Assessing Officials shall complete Form A-5W, Warrant For Land Use Change Tax, as approved by the board, to serve as the warrant with which the Municipal Tax Collector shall collect the Land Use Change Tax from the landowner or the right-of-way responsible party.

WHERE TO FILE

The completed and signed original Form A-5W shall accompany the original Form A-5 and two copies to be delivered to the Municipal Tax Collector. The Municipal Assessing Officials shall retain a copy of both the Form A-5 and the Form A-5W for their records.

TAX COLLECTOR PROCEDURES

Upon receipt of the Form A-5W, Warrant For Land Use Change Tax, and Form A-5, Municipality Land Use Change Tax Bill, the Municipal Tax Collector shall mail a duplicate copy of the Form A-5 to the owner responsible for the tax as the notice thereof. Such bill shall be mailed, at the latest, within 18 months of the date upon which the Municipal Assessing Officials receive written notice of the change of use from the landowner or his agent, or within 18 months of the date the Municipal Assessing Officials actually discover that the Land Use Change Tax is due and payable. Upon receipt of payment from the property owner, the Municipal Tax Collector shall forward the original Form A-5 to the county registry of deeds for the purpose of releasing the recorded contingent lien as indicated by the A-5 on all, or only a portion of the property. The recording fee shall be payable by the property owner. Upon receipt of payment from the right-of-way responsible party, the Form A-5 does not get recorded at the registry of deeds. In either case, a copy of the paid Form A-5 bill shall be given to the Municipal Assessing Officials for their records.

WHEN TAX IS DUE

Payment of Land Use Change Tax and the recording fee shall be due not later than 30 days after mailing of the tax bill. Interest at the rate of 18 percent per annum shall be due on any taxes not paid within the 30-day period.

COLLECTION OF UNPAID TAX

Land Use Change Tax assessments create a lien against the property owner or the right-of-way responsible party. The tax lien shall continue for a period of 24 months. Unpaid tax is subject to collection proceedings pursuant to RSA 80.

ADA

Individuals who need auxiliary aids for effective communication in programs and services of the department are invited to make their needs and preferences known to the New Hampshire Department of Revenue Administration.

NEED HELP?

Contact the Municipal and Property Division at (603) 230-5950.

LINE-BY-LINE FORM INSTRUCTIONS

STEP 1

The Municipal Assessing Officials shall provide the name of the municipality and mailing address in which the taxable property is located.

STEP 2

- (a) Name of the county in which the property is located.
- (b) Name of the Municipal Tax Collector.
- (c) Name of the municipality in which the property is located.
- (d) The amount of Land Use Change Tax due and payable.
- (e) The name of the municipality.
- (f) The month, day, and year of the warrant.
- (g) The property owner or right-of-way responsible party and address to whom the tax is being assessed.
- (h) The tax map and lot number of the property on which the Land Use Change Tax is being assessed.

STEP 3

Signature of a majority of the Municipal Assessing Officials and date of signature indicates approval.

FORM
A-5

**NEW HAMPSHIRE DEPARTMENT OF REVENUE ADMINISTRATION
MUNICIPALITY LAND USE CHANGE TAX BILL**

STEP 1 - LAND USE CHANGE TAX TO BE BILLED TO:

PROPERTY OWNER(S) OR **RIGHT OF WAY RESPONSIBLE PARTY LISTED BELOW:**

PLEASE TYPE OR PRINT	LAST NAME/CORPORATION/TRUST NAME VITALE	FIRST NAME/CORPORATION/TRUST NAME FRANK	INITIAL E
	LAST NAME/CORPORATION/TRUST NAME VITALE	FIRST NAME/CORPORATION/TRUST NAME AUDREY	INITIAL H
	LAST NAME/CORPORATION/TRUST NAME	FIRST NAME/CORPORATION/TRUST NAME	INITIAL
	LAST NAME/CORPORATION/TRUST NAME	FIRST NAME/CORPORATION/TRUST NAME	INITIAL
	MAILING ADDRESS 896 CRANEY HILL ROAD		
MUNICIPALITY HENNIKER		STATE NH	ZIP CODE 03242

STEP 2 - PARCEL IDENTIFICATION OF DISQUALIFIED CURRENT USE LAND

PLEASE TYPE OR PRINT	(a) RIGHT OF WAY LAND USE CHANGE TAX - PROVIDE NAME OF LANDOWNER ON WHICH THE RIGHT OF WAY IS LOCATED			
	(b) ACCESSIBLE STREET LOCATION 896 CRANEY HILL ROAD		MUNICIPALITY HENNIKER	COUNTY MERRIMACK
	(c) TOTAL ACRES OF PARCEL 4.16	PARCEL TAX MAP AND LOT # 11	DEED BOOK AND PAGE # 649-A 3845 2428	
	(d) CHECK ONE BELOW: <input type="checkbox"/> PARTIAL RELEASE <input checked="" type="checkbox"/> FULL RELEASE <input type="checkbox"/> RIGHT OF WAY LAND USE CHANGE TAX			

NOTE: A separate land use change tax (LUCT) must be submitted for each separate parcel of land.

STEP 3 - DOCUMENTATION AND FEE FOR PROPERTY TO BE ENROLLED IN CURRENT USE (CU)

(a) Owners Name When Land Was First Recorded in Current Use: MERLE R. PATENAUDE JR & BEVERLY B PATENAUDE	DEED BOOK AND PAGE # 1725 0096	
(b) Total Number of Acres Originally Enrolled in Current Use	3.75	
(c) Total Number of Acres Previously Released Since The Original Recording	.74	
(d) Number of Acres Subject to the LUCT Per This Assessment	3.01	
(e) Number of Acres Remaining in Current Use [3(b) minus 3(c) and 3(d)]	0	

FORM
A-5

NEW HAMPSHIRE DEPARTMENT OF REVENUE ADMINISTRATION
MUNICIPALITY LAND USE CHANGE TAX BILL
 (continued)

STEP 4 - ASSESSMENT OF LAND USE CHANGE TAX

(a) Narrative Description of the Disqualification: PROPERTY SOLD 12.21.2023 AND IS NO LONGER UNDER CONTIGUOUS IDENTICAL OWNERSHIP.	
(b) Actual Date of Change in Use (MM/DD/YYYY)	12/21/2023
(c) Full and True Market Value at Time of Change in Use	\$ 6,800
(d) Land Use Change Tax [Step 4(c) multiplied by 10%]	\$ 680 + \$20 Recording Fee=

STEP 5 - SIGNATURES OF A MAJORITY OF THE MUNICIPAL ASSESSING OFFICIALS

=\$700.00

<small>TYPE OR PRINT NAME (in black or dark blue ink)</small> KRIS BLOMBACK	<small>SIGNATURE (in black or dark blue ink)</small>	<small>DATE</small> 02/20/2024
<small>TYPE OR PRINT NAME (in black or dark blue ink)</small> BILL MARKO	<small>SIGNATURE (in black or dark blue ink)</small>	<small>DATE</small> 02/20/2024
<small>TYPE OR PRINT NAME (in black or dark blue ink)</small> D. SCOTT OSGOOD	<small>SIGNATURE (in black or dark blue ink)</small>	<small>DATE</small> 02/20/2024
<small>TYPE OR PRINT NAME (in black or dark blue ink)</small> NEAL MARTIN	<small>SIGNATURE (in black or dark blue ink)</small>	<small>DATE</small> 02/20/2024
<small>TYPE OR PRINT NAME (in black or dark blue ink)</small> JEFF MORSE	<small>SIGNATURE (in black or dark blue ink)</small>	<small>DATE</small> 02/20/2024

STEP 6 - BILL LAND USE CHANGE TAX TO:

(COMPLETED BY MUNICIPAL ASSESSING OFFICIALS)

<small>LAST NAME/CORPORATION/TRUST NAME</small> VITALE		<small>FIRST NAME/CORPORATION/TRUST NAME</small> FRANK & AUDREY		<small>INITIAL</small>
<small>MAILING ADDRESS</small> 896 CRANEY HILL ROAD				
<small>MUNICIPALITY</small> HENNIKER		<small>STATE</small> NH	<small>ZIP CODE</small> 03242	
(b) Actual Date of Change in Use (MM/DD/YYYY)		12/21/2023		
(c) Date of Land Use Change Tax Bill (MM/DD/YYYY)		02/22/2024		
(d) Full and True Market Value at Time of Change in Use		\$ 6,800		
(e) Land Use Change Tax Due		\$ 680+ \$20 Fee = \$700.00		

FORM
A-5

NEW HAMPSHIRE DEPARTMENT OF REVENUE ADMINISTRATION
MUNICIPALITY LAND USE CHANGE TAX BILL

(continued)

STEP 7 - CHECKS PAYABLE AND MAILED TO: (COMPLETED BY MUNICIPAL TAX COLLECTOR)

(a) MAKE CHECKS PAYABLE TO: TOWN OF HENNIKER		
(b) MAIL TO: DEBORAH C. AUCOIN		
MAILING ADDRESS: 18 DEPOT HILL ROAD		
MUNICIPALITY HENNIKER	STATE NH	ZIP CODE 03242
(c) MUNICIPAL TAX COLLECTOR PHYSICAL OFFICE LOCATION: 18 DEPOT HILL ROAD, HENNIKER, NH 03242		
(d) MUNICIPAL TAX COLLECTOR OFFICE HOURS: MON, WED, & FRI 8:00 AM - 4:00 PM, TUE 10:00 AM - 6:00 PM, THU CLOSED		
(e) LAND USE CHANGE EXEMPT FROM RECORDING RSA 79-A:7, I (c): <input type="checkbox"/> Yes <input type="checkbox"/> No		
(f) RECORDING FEE: INCLUDE A SEPARATE CHECK IN THE AMOUNT OF \$ _____		
PAYABLE TO:		
(g) PAYMENT OF THE LAND USE CHANGE TAX IS DUE NO LATER THAN 30 DAYS AFTER MAILING OF THIS BILL. INTEREST, AT THE RATE OF 18% PER ANNUM, SHALL BE DUE IF THE TAX IS NOT PAID ON OR BEFORE: _____		

STEP 8 - ACKNOWLEDGEMENT OF PAYMENT (COMPLETED BY MUNICIPAL TAX COLLECTOR)

TYPE OR PRINT NAME (in black or dark blue ink)	SIGNATURE OF MUNICIPAL TAX COLLECTOR (in black or dark blue ink)	DATE OF PAYMENT
--	--	-----------------

FORM
A-5

NEW HAMPSHIRE DEPARTMENT OF REVENUE ADMINISTRATION
MUNICIPALITY LAND USE CHANGE TAX BILL
INSTRUCTIONS
GENERAL INSTRUCTIONS

WHO MUST FILE

The Municipal Assessing Officials shall complete the Form A-5, Municipality Land Use Change Tax Bill, to assess the Land Use Change Tax on land that has been classified as open space land and assessed at current use values on or after April 1, 1974 that has undergone a change and as such, no longer qualifies for current use assessment.

WHEN TO FILE

Municipal Assessing Officials shall assess the Land Use Change Tax within 18 months of the date upon which they receive written notice of the change of use from the landowner or his or her agent, or within 18 months of the date the Municipal Assessing Officials actually discover the Land Use Change Tax is due and payable.

WHERE TO FILE

Upon approval and signature of the Form A-5 by the majority of the Municipal Assessing Officials, the original and two copies of the Form A-5 along with the Form A-5W, Land Use Change Tax Warrant, shall be submitted to the Municipal Tax Collector for collection of the Land Use Change Tax. A copy of the Form A-5 and Form A-5W shall be retained by the Municipal Assessing Officials.

BILLING AND COLLECTION OF THE TAX

Upon receipt of the Land Use Change Tax Warrant, the Municipal Tax Collector shall mail one copy of the Form A-5 and this instruction page to the property owner of right-of-way responsible party. Payment of the Land Use Change Tax shall be due no later than 30 days after the mailing of the Form A-5 bill. If billed to the property owner, they must pay a recording fee. Interest of 18% will accrue on any unpaid tax after 30 days. Upon receipt of payment by the property owner, the Form A-5 is recorded at the country registry of deeds. Upon receipt of payment by the right-of-way responsible party, the Form A-5 is not recorded at the registry of deeds. Copies of the paid Form A-5 bills shall be given to the Municipal Assessing Officials for their records.

APPEAL OF LAND USE CHANGE TAX

Any person aggrieved by the assessment of a Land Use Change Tax may, within 2 months of the notice of tax date and not afterwards, apply in writing to the Municipal Assessing Officials for an abatement of the Land Use Change Tax pursuant to RSA 79-A:10. If the Municipal Assessing Officials neglect or refuse to abate the Land Use Change Tax, any person aggrieved may appeal within 8 months of the notice of tax date and not afterwards, to either the Board of Tax and Land Appeals or Superior Court in accordance with RSA 79-A:10 or RSA 79-A:11.

ADA

Individuals who need auxiliary aids for effective communication in programs and services of the department are invited to make their needs and preferences known to the NH Department of Revenue Administration.

NEED HELP?

Contact your Municipality or Municipal and Property Division at (603) 230-5950.

FORM
A-5

NEW HAMPSHIRE DEPARTMENT OF REVENUE ADMINISTRATION
MUNICIPALITY LAND USE CHANGE TAX BILL
INSTRUCTIONS

LINE-BY-LINE INSTRUCTIONS

The Municipal Assessing Officials shall complete Steps 1 through 6. Steps 7 and 8 shall be completed by the Municipal Tax Collector.

STEP 1

Indicate whether the property owner or the right-of-way responsible party will be assessed the tax. Provide the names and address of the party to whom the tax is being assessed.

STEP 2

- (a) If assessed to the right-of-way responsible party, list the name of the parcel landowner on which the change occurred.
- (b) Provide the parcel street location, municipality, and country on which the change in use occurred.
- (c) Provide the total acres of the parcel, tax map and lot number, and most recent deed reference for the parcel.
- (d) Indicate whether a portion of the parcel or the entire parcel is being released, or that it is a right-of-way change.

STEP 3

- (a) Provide the name of the property owner(s) that originally enrolled the land into current use including the registry of deeds book and page recording the reference.
- (b) Enter the total acres originally enrolled in current use.
- (c) Enter the total acres previously released since the original enrollment into current use.
- (d) Enter the number of acres subject to the Land Use Change Tax for this assessment.
- (e) Enter the number of acres remaining in current use, Step 3(b) minus Step 3(c) minus Step 3 (d).

STEP 4

- (a) Provide the description of the land disqualification.
- (b) Provide the actual date of the event that disqualified the land in the following format: MM/DD/YYYY.
- (c) Provide the full and true market value of the land at the time of change in use.
- (d) Calculate the Land Use Change Tax by multiplying the full and true market value of the land by 10% (.10).

STEP 5

Signature of a majority of the Municipal Assessing Officials and date of signature indicates approval.

STEP 6

- (a) Provide the name and address of the party to whom the tax is to be billed.
- (b) Provide the actual date of the event that disqualified the land in Step 4(b) in the following format: MM/DD/YYYY.
- (c) Enter the date of the Land Use Change Tax Notice.
- (d) Enter the full and true market value at the time of change in use as indicated in Step 4(c).
- (e) Enter the Land Use Change Tax owed as calculated on page 2, Step 4(d).

STEP 7

- (a) Enter the name of the municipality to which the checks are to be made payable. This should be the municipality in which the parcel of land is located.
- (b) Enter the name of the Municipal Tax Collector and the applicable mailing address to which payments should be remitted.
- (c) Enter the Municipal Tax Collector's physical office location.
- (d) Enter the Municipal Tax Collector's hours of operation.
- (e) If the Land Use Change Tax is being billed to the right-of-way responsible party, it is exempt from recording and the box should be checked "Yes". If the Land Use Change Tax is being billed to the property owner, it is not exempt and the box should be checked "No".
- (f) Enter the applicable county registry of deeds recording and filing fee for the recording of the lien release. Indicate to whom the recording fee check should be made payable.
- (g) Enter the final date that the taxpayer has to pay the bill to avoid late payment penalties.

STEP 8

The Municipal Tax Collector shall sign and date the form when the tax is paid, and if applicable, the Municipal Tax Collector shall remit the original signed Form A-5 with the recording fee to the appropriate County Registry of Deeds. Copies of the paid, and if applicable the recorded, Form A-5 shall be provided to the Municipal Assessing Officials for their record.



Avitar Associates of New England, Inc.

A Municipal Services Company

Received by
TOWN OF HENNIKER

January 24, 2024

JAN 29 2024

**Town of Henniker
Helga Winn
Board of Selectmen
18 Depot Hill Road
Henniker, NH 03242**

SELECTMEN'S OFFICE

Re: LUCT Recommendations - Map 11, Lot 649 Sub A (896 Craney Hill Road – Vitale, Frank & Audrey)

Dear Helga & Board Members:

Map 11, Lot 649 Sub A

The above-referenced parcel consists of 4.160 acres, of which 3.010 acres are in current use, as it was contiguous with an abutting lot. However, this property was recently sold on December 21, 2023, pursuant to Book 3845 Page 2428 and due to the ownership change, no longer meets the 10 acres (or more) of contiguous identical ownership to qualify for current use. As such, they are now subject to a land use change tax (LUCT). As the home site, which carries most of the value was already out of current use, this 3.010-acre area was determined using our established excess acreage rate of \$2,500 per acre and further adjusting for topography (-10%). Therefore, it is my opinion this 3.010 acres has a market value of \$6,800, revealing a \$680 LUCT (\$6,800 x 10%). The date of change should be noted as December 21, 2023, the date the ownership change was recorded at the registry.

Once this recommendation is received, a land use change tax form (A-5) and the tax warrant need to be completed, signed by the Board, and provided to the Tax Collector for processing.

As always, should you have questions or concerns, please do not hesitate to contact me.

Sincerely,



**Evan Roberge
Assessor Supervisor**

ER/sjc

**TOWN OF HENNIKER
PAYROLL CHECK REGISTERS
DATE: FEBRUARY 14, 2024**

**WAGES: \$51,051.06
PAYROLL DEDUCTIONS: \$10,769.55
TOTAL: \$61,820.61**

BOARD OF SELECTMEN APPROVAL

<hr/> Kris Blomback	Date
<hr/> Scott Osgood	Date
<hr/> Bill Marko	Date
<hr/> Neal Martin	Date
<hr/> Jeff Morse	Date

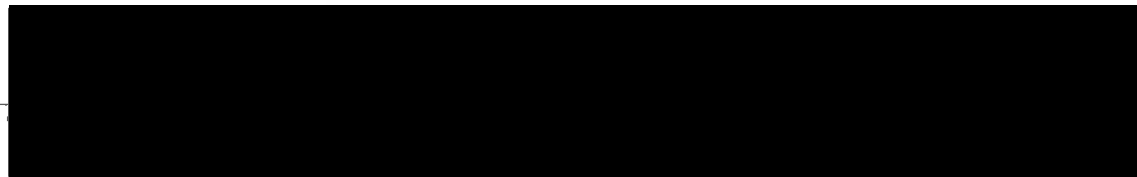

<hr/> Treasurer	Date
------------------------	-------------

DEPARTMENTAL HOURS AND GROSS SUMMARY REPORT FOR TOWN OF HENNIKER
For 02/14/2024 to 02/14/2024

Pay Code	Regular Hours	Suppl. Hours	Regular Gross	OT Hours	OT Gross
Department: CODE CODE					
Department Totals For: CODE					
SALARY	18.00	0.00	485.57	0.00	0.00
Totals:	18.00	0.00	485.57	0.00	0.00
Department: CSWW CSWW					
Department Totals For: CSWW					
REGULAR	43.50	0.00	2,183.46	0.00	0.00
Totals:	43.50	0.00	2,183.46	0.00	0.00
Department: EXECUTIVE EXECUTIVE					
Department Totals For: EXECUTIVE					
REGULAR	72.75	0.00	1,725.50	0.00	0.00
SALARY	49.75	0.00	2,003.75	0.00	0.00
Totals:	122.50	0.00	3,729.25	0.00	0.00
Department: FINANCE FINANCE					
Department Totals For: FINANCE					
DISABILITY	0.00	0.00	534.69	0.00	0.00
SALARY	51.00	0.00	1,662.40	0.00	0.00
Totals:	51.00	0.00	2,197.09	0.00	0.00
Department: FIRE/RESCUE FIRE/RESCUE					
Department Totals For: FIRE/RESCUE					
REGULAR	50.00	0.00	1,103.92	0.00	0.00
STIPEND	0.00	0.00	480.77	0.00	0.00
Totals:	50.00	0.00	1,584.69	0.00	0.00
Department: HIGHWAY HIGHWAY					
Department Totals For: HIGHWAY					
REGULAR	219.00	0.00	6,054.68	0.00	0.00
SICK	5.00	0.00	111.40	0.00	0.00
USECOMP	8.00	0.00	238.72	0.00	0.00
VACATION	8.00	0.00	211.20	0.00	0.00
Totals:	240.00	0.00	6,616.00	0.00	0.00
Department: LIBRARY LIBRARY					
Department Totals For: LIBRARY					
REGULAR	72.50	0.00	1,598.41	0.00	0.00
SALARY	40.00	0.00	1,608.40	0.00	0.00
Totals:	112.50	0.00	3,206.81	0.00	0.00
Department: POLICE POLICE					
Department Totals For: POLICE					
EVENING OT	0.00	0.00	0.00	7.00	412.65
EVENING PAY	89.25	0.00	2,914.38	0.00	0.00
MIDNIGHT PAY	75.25	0.00	1,857.92	0.00	0.00
REGULAR	205.75	0.00	6,679.23	0.00	0.00
REGULAR OT	0.00	0.00	0.00	11.00	585.14
VACATION	53.75	0.00	1,506.61	0.00	0.00
Totals:	424.00	0.00	12,958.14	18.00	997.79
Department: RESCUE RESCUE					
Department Totals For: RESCUE					

DEPARTMENTAL HOURS AND GROSS SUMMARY REPORT FOR TOWN OF HENNIKER
For 02/14/2024 to 02/14/2024

Pay Code	Regular Hours	Suppl. Hours	Regular Gross	OT Hours	OT Gross
OVERTIME	0.00	0.00	0.00	13.00	414.57
REGULAR	285.50	0.00	7,106.40	0.00	0.00
VACATION	16.66	0.00	405.34	0.00	0.00
Totals:	302.16	0.00	7,511.74	13.00	414.57

Department: SW/GGB/P&P SOLID WASTE/GEN GOV BLDG/P&P
Department Totals For: SW/GGB/P&P

REGULAR	138.50	0.00	3,247.87	0.00	0.00
USECOMP	1.50	0.00	37.94	0.00	0.00
Totals:	140.00	0.00	3,285.81	0.00	0.00

Department: TC/TX TOWN CLERK / TAX COLLECTOR
Department Totals For: TC/TX

REGULAR	38.00	0.00	758.48	0.00	0.00
SALARY	45.25	0.00	1,292.92	0.00	0.00
SICK	2.00	0.00	39.92	0.00	0.00
Totals:	85.25	0.00	2,091.32	0.00	0.00

Department: WELFARE WELFARE
Department Totals For: WELFARE

REGULAR	12.00	0.00	254.88	0.00	0.00
Totals:	12.00	0.00	254.88	0.00	0.00

Department: WTP WASTE WATER TREATMENT PLANT
Department Totals For: WTP

OVERTIME	0.00	0.00	0.00	2.00	106.74
REGULAR	85.00	0.00	2,545.89	0.00	0.00
USECOMP	17.00	0.00	417.35	0.00	0.00
VACATION	18.00	0.00	463.96	0.00	0.00
Totals:	120.00	0.00	3,427.20	2.00	106.74

Grand Totals:

DISABILITY	0.00	0.00	534.69	0.00	0.00
EVENING OT	0.00	0.00	0.00	7.00	412.65
EVENING PAY	89.25	0.00	2,914.38	0.00	0.00
MIDNIGHT PAY	75.25	0.00	1,857.92	0.00	0.00
OVERTIME	0.00	0.00	0.00	15.00	521.31
REGULAR	1,222.50	0.00	33,258.72	0.00	0.00
REGULAR OT	0.00	0.00	0.00	11.00	585.14
SALARY	204.00	0.00	7,053.04	0.00	0.00
SICK	7.00	0.00	151.32	0.00	0.00
STIPEND	0.00	0.00	480.77	0.00	0.00
USECOMP	26.50	0.00	694.01	0.00	0.00
VACATION	96.41	0.00	2,587.11	0.00	0.00
Totals:	1,720.91	0.00	49,531.96	33.00	1,519.10

02/12/2024
02:27 PM

Remittance Invoice Report

Page: 1/1

Vendor	Item Code	GL Number	Amount
IRS - IRS PAYMENT			
	FITW	01-0000-2025-001	4,327.03
	SOCSEC_EE	01-0000-2025-001	2,314.57
	SOCSEC_ER	01-0000-2025-001	2,314.57
	MEDICARE_EE	01-0000-2025-001	721.97
	MEDICARE_ER	01-0000-2025-001	721.97

Invoice Total: 10,400.11

Sub Totals:

FITW	4,327.03
MEDICARE	1,443.94
SOCSEC	4,629.14

EMPOWER - EMPOWER RETIREMENT

EMPOWER	01-0000-2025-020	107.50
EMPOWER-ROTH	01-0000-2025-020	261.94

Invoice Total: 369.44

Sub Totals:

EMPOWER	107.50
EMPOWER-ROTH	261.94

Grand Totals:

Invoice Count: 2 10,769.55

Sub Totals:

EMPOWER	107.50
EMPOWER-ROTH	261.94
FITW	4,327.03
MEDICARE	1,443.94
SOCSEC	4,629.14

Check Proofing Report

02/12/2024
12:02 PM

42/43

Payroll ID: 00000076

Check Post Date: 02/14/2024

Pay Period End Date: 02/10/2024

Grand Totals:

Num. Checks Payable:	3	Total Gross:	51,051.06	Reg. Hours:	1,720.91	Total Deductions:	11,947.74
Number of Checks:	3	Total Net:	39,103.32	OT Hours:	33.00	Ded. Adj. Aff. Gross:	0.00
Number of DD:	53	Direct Deposit:	37,737.88	Suppl Hours:	0.00	Total Expense:	3,307.65
				Comp Hrs Wrkd:	3.75		

Tax Type	State / Loc.	App Pay	Prior Ded	Tax Gross
Social Security		38,102.77	771.35	37,331.42
Medicare		51,051.06	1,259.41	49,791.65
Federal		51,051.06	4,260.61	46,790.45

Paycode ID	Amount	Reg Hours	Sup Hours	OT Hours	Ded/Exp Code	Amt
DISABILITY	534.69	0.00	0.00	0.00	AFLAC	61.62
EVENING OT	412.65	0.00	0.00	7.00	DENTAL	261.27
EVENING PAY	2,914.38	89.25	0.00	0.00	EMPOWER	107.50
MIDNIGHT PAY	1,857.92	75.25	0.00	0.00	EMPOWER-ROTH	261.94
OVERTIME	521.31	0.00	0.00	15.00	FITW	4,327.03
REGULAR	33,258.72	1,222.50	0.00	0.00	FSA	138.03
REGULAR OT	585.14	0.00	0.00	11.00	MEDICAL	860.11
SALARY	7,053.04	204.00	0.00	0.00	MEDICARE_EE	721.97
SICK	151.32	7.00	0.00	0.00	MEDICARE_ER	721.97
STIPEND	480.77	0.00	0.00	0.00	NHRSEMP	1,395.71
USECOMP	694.01	26.50	0.00	0.00	NHRSPD	116.73
VACATION	2,587.11	96.41	0.00	0.00	NHRSPD	848.41
					NHRSPD W DETAIL	532.85
					SOCSEC_EE	2,314.57
					SOCSEC_ER	2,314.57
					TA_457	271.11
					ARMED FORCES BANK	710.13 DEPOSIT
					BANK OF AMERICA	1,401.53 DEPOSIT
					BANK OF NH	451.06 DEPOSIT
					BAR HARBOR BANK	4,206.47 DEPOSIT
					CHARLES SCHWAB	864.58 DEPOSIT
					CITIZENS BANK	587.31 DEPOSIT
					CITIZENS BANK NA	8,254.72 DEPOSIT
					GRANITE STATE CU	1,160.19 DEPOSIT
					MERRIMACK CO SVGS	1,925.21 DEPOSIT
					MFCU	1,226.46 DEPOSIT
					NAVY	1,764.46 DEPOSIT
					NHFCU	3,765.91 DEPOSIT
					NORTHEAST	707.54 DEPOSIT
					SERVICE CU	230.12 DEPOSIT

= Deposited Ded/Exp * = Check Adjustment >> = Pre-Tax Deductions capped at Applicable Gross

Check Proofing Report

02/12/2024
12:02 PM

43/43

Payroll ID: 00000076

Check Post Date: 02/14/2024

Pay Period End Date: 02/10/2024

Paycode ID	Amount	Reg Hours	Sup Hours	OT Hours	Ded/Exp Code		Amt			
					SUGAR	858.73	DEPOSIT			
					TD BANK NA	7,089.30	DEPOSIT			
					USAA FED SVGS BANK	2,534.16	DEPOS			
Leave Bank Code	Leave ID	Prev. Bal.	Comp Wrkd	Accrued	Lost	Taken	Buy Out	Adjusted	Net Change	New Balance
COMP EARNED	COMP EARNED	428.65	3.75	5.63	0.00	26.50	0.00	0.00	-20.87	407.78
MILITARY	MILITARY	376.25		0.00	0.00	0.00	0.00	0.00	0.00	376.25
SICK	SICK	5,227.05		0.00	0.00	7.00	0.00	0.00	-7.00	5,220.05
	FT POLICE SICK			0.00						
	FT FIRE SICK			0.00						
VACATION	VACATION	2,098.27		0.00	0.00	96.41	0.00	0.00	-96.41	2,001.86
	TOWN ADMIN VAC			0.00						
	FT POLICE VAC			0.00						
	FT FIRE VAC			0.00						
Status	Count									
Active	56									

= Deposited Ded/Exp * = Check Adjustment >> = Pre-Tax Deductions capped at Applicable Gross

**TOWN OF HENNIKER
ACCOUNTS PAYABLE MANIFEST
DATE: FEBRUARY 21, 2024**

TOTAL: \$1,136,430.43

BOARD OF SELECTMEN APPROVAL

Kris Blomback	Date
Scott Osgood	Date
Bill Marko	Date
Neal Martin	Date
Jeff Morse	Date

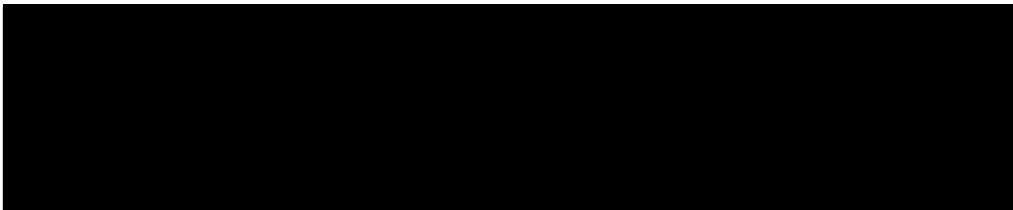

Treasurer	Date
------------------	-------------



TOWN OF HENNIKER
APPOINTMENT

To **Stefanie Costello** of Henniker, in the County of Merrimack:

WHEREAS, there is a vacancy in the position of **Emergency Management Director**, in the **Town of Henniker**, and whereas we, the subscribers, have confidence in your ability and integrity to perform the duties of said position, we do hereby appoint you, the said **Stefanie Costello**, as **Emergency Management Director** for the **Town of Henniker**. Your tenure as **Emergency Management Director** for the **Town of Henniker** will continue until the end of your term on December 31, 2026.

Upon your taking the oath of office, and having this appointment and the certificate of said office recorded by the Town Clerk, you shall have the powers, perform the duties, and be subject to the responsibilities of such office.

Given under our hands on the appointment day of February 20, 2024.

BOARD OF SELECTMEN:

I, **Stefanie Costello**, do solemnly swear that I will faithfully and impartially discharge and perform all the duties incumbent on me as **Emergency Management Director** for the **Town of Henniker**, according to the best of my abilities, agreeable to the rules and regulations of the constitution and laws of the State of New Hampshire, SO HELP ME GOD (This I do under the pains and penalties of perjury).

Stefanie Costello

STATE OF NEW HAMPSHIRE
COUNTY OF MERRIMACK

Personally appeared the above, **Stefanie Costello**, who took and subscribed the foregoing oath. Before me,

Date: _____

Town Clerk received and recorded (signature): _____

Verified I.D.



Town of Henniker
18 Depot Hill Road
Henniker, NH 03242
Phone (603) 428-3221 / Fax (603) 428-4366
www.henniker.org

APPLICATION FOR VOLUNTEER POSITION

POSITION:

This is my first time volunteering for this position

I am reapplying for this position

NAME (as it should appear):

Why are you seeking this appointment?

What experience would you bring to this position?

Do you have any specific goals or objectives you would seek to implement if you were appointed to this position?

SIGNATURE: _____

Date: _____

APPOINTMENTS WITH THE BOARD



Town of Henniker
 18 Depot Hill Road
 Henniker, NH 03242
 Phone (603) 428-3221 / Fax (603) 428-4366
 www.henniker.org

Received by
 TOWN OF HENNIKER

FEB 08 2024

SELECTMEN'S OFFICE

Assigned Permit #: SE 24-05

APPLICATION FOR SPECIAL EVENT PERMIT On Town of Henniker Property

ACTIVITY & TITLE OF EVENT: HENNIKER HANDMADE & HOME GROWN

DATE OF APPLICATION: 2/8/24

EVENT DATE & HOURS: MAY 11 & 12
SEPT. 28 & 29 } 10 AM - 4 PM
 ALL DAYS

Will this event be held at: Check all that apply

<input checked="" type="checkbox"/> Community Park and Bandstand	<input type="checkbox"/> Baseball Field
<input checked="" type="checkbox"/> Community Parking Lot	<input type="checkbox"/> Soccer Fields
<input checked="" type="checkbox"/> Community Building	<input type="checkbox"/> Woodman Park
<input type="checkbox"/> Grange	<input type="checkbox"/> Town Hall Common
<input type="checkbox"/>	<input type="checkbox"/>

EVENT SPONSOR

NAME: MONICA RICO / HENNIKER COMMUNITY MARKET
 ADD: [REDACTED]
 PHO: [REDACTED]
 EMA: [REDACTED]

SECONDARY CONTACT: _____ PHONE: _____
 ADDRESS: _____
 EMAIL ADDRESS: _____

SPECIAL EVENT CONTACT INFORMATION

SPONSOR: HENNIKER COMMUNITY MARKET PHON: [REDACTED]
 ORGANIZERS/CONTACT NAME: MONICA RICO PHON: [REDACTED]
 ADDRESS: [REDACTED]
 EMAIL ADD: [REDACTED]

ON SITE ORGANIZER: [REDACTED]
 ADDRESS: [REDACTED]
 EMAIL ADDRESS: [REDACTED]

EVENT INFO

DESCRIPTION OF EVENT:
VENDOR FAIR w/ ARTISTS, FARMS, FOOD TRUCKS,
 LIVE MUSIC, KIDS ACTIVITIES

Drawing / Map: If this is a walk, race or any event that will take place in multiple areas, please include a DRAWING that shows: parking, start/end locations, and the exact route, including areas to be kept open for emergency vehicles.

Site Plan and Floor Plan

MINIMUM ESTIMATED ATTENDANCE: 200 MAXIMUM ESTIMATE ATTENDANCE: 1000

Should attendance exceed the maximum listed above, what plan will be followed?

BECAUSE THIS IS AN OUTDOOR EVENT, WE'VE NEVER HAD AN ISSUE WITH TOO MANY ATTENDEES.

SET UP TIME: FRIDAY 5:00 PM & SATURDAY @ 7:00 AM CLEAN UP TIME: SUNDAY 4:00 PM - 6:00 PM

Describe provisions for cleanup of premises and removal of rubbish:

VENDORS ARE RESPONSIBLE FOR REMOVAL OF THEIR OWN TRASH. VOLUNTEERS WILL CLEAN UP THE PARK & COMMUNITY CENTER.

DESCRIPTION OF PROVISIONS		
WATER SUPPLY FROM: FOOD TRUCKS		
FOOD WILL BE SERVED FROM AND/OR BY: FOOD TRUCKS } TBD.		
BEVERAGES WILL BE SERVED FROM AND/OR BY: FOOD TRUCKS		
TYPE OF ALCOHOLIC BEVERAGES TO BE SERVED: N/A		
NO. OF SANITATION UNITS (toilets): 2	MALE: -	FEMALE: -
ILLUMINATION AFTER DARK WILL BE PROVIDED BY: N/A		
MEDICAL AND FIRST AID AVAILABLE FROM OR BY: FIRST AID KIT ON SITE		
TRAFFIC CONTROL PROVIDED BY: *		NO. OF OFFICERS:
PARKING FOR * NUMBER OF CARS IS PLANNED. SUPPLEMENTED		
<input type="checkbox"/> Attach plan of exact parking location and exact route to be kept open for emergency vehicles. <input checked="" type="checkbox"/> Not applicable. Explain: OVERFLOW PARKING @ HENNIKER COMMUNITY SCHOOL		

IS THIS EVENT...	<input checked="" type="checkbox"/> YES	<input checked="" type="checkbox"/> NO	IF YES:
• ... using a tent (or tents) 400+ sq ft?	<input type="checkbox"/>	<input checked="" type="checkbox"/>	Please submit a TENT INSTALL APPLICATION
• ... planning to have vendors, hawkers, or peddlers*?	<input type="checkbox"/>	<input checked="" type="checkbox"/>	Please have each vender/hawker/peddler submit an APPLICATION FOR A HAWKER, PEDDLER OR ITINERANT VENDOR LICENSE
• ... conducting a raffle?	<input checked="" type="checkbox"/>	<input type="checkbox"/>	Please submit a RAFFLE PERMIT APPLICATION

*EXCLUDING: Any person selling the product of his own labor or the labor of his family or the product of his own farm or the one he tills. Farmers markets if permission of location is authorized by the owner of the land or building.

* HHA vendors are subject to NH Liquor Commission Regulation. Past markets included NOK VINO please submit City Home Approval forms at least 4 weeks prior to the event. (DK.)

12/20/2023 * Will traffic control be provided by HHA - Police Chief did not recommend a special detail.

* How many cars per hour are parked? 2

APPLICANT/SPONSOR/PERMITTEE:

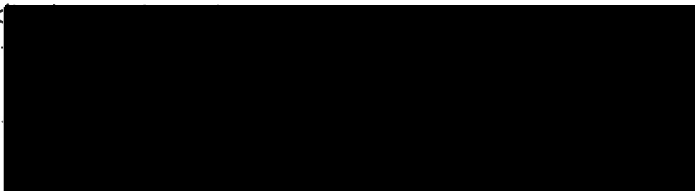
I, MONICA RICO, do hereby accept all responsibility for the above described event. I agree to adhere to all laws and regulations of the Town of Henniker and the State of New Hampshire. I do hereby consent to the entry, at any time, in the course of his/her duties, any town officer in the performance of his/her duties, including  whatever surety is deemed necessary by the Board of Selectmen. The above is true.

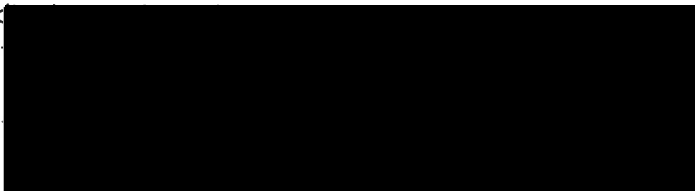
Signature:  Date: 2/8/2024

Printed name: MONICA RICO

DO NOT WRITE BELOW THIS SPACE – INTERNAL-USE ONLY

DEPARTMENTAL APPROVALS: Please attach any comments or special requirements to the application.

- Fire Chief: See attached Date: 2-13-24
- Health Officer: see attached Date: 2-13-24
- Code Enforcement Officer: See Attached Date: 2-13-24
- Highway Superintendent: [Signature] Date: 2/14/24
- Water Superintendent: see attached Date: 2/14/24
- Wastewater Superintendent: see attached Date: 2-13-24
- Rescue Squad Chief: see attached Date: 2/13/24
- Police Chief: [Signature] Date: 2-13-24
- Town Administrator: _____ Date: _____

See comments highlighted

HENNIKER BOARD OF SELECTMEN

SELECTBOARD CHAIR: _____ Date: _____

SELECTMAN: _____ Date: _____

SELECTMAN: _____ Date: _____

SELECTMAN: _____ Date: _____

SELECTMAN: _____ Date: _____

Denied Reason: _____

Approved Having reviewed the above-described event we do hereby grant permission for this event to take place at the time and hours indicated. **Deposit** in the amount of \$ _____ is required.

PERMITTEE: I do hereby agree to these additional requirements and/or comments:

PERMITEE Signature: _____ Date: _____

COMMUNITY CENTER PARK

(TO FOOD TRUCKS + KIDS ZONE)



= STANDARD
(1 SIDE OPEN)

= PREMIUM
(2 SIDES OPEN)



= DELUXE
(3+ SIDES OPEN)

FRONT OF COMMUNITY CENTER

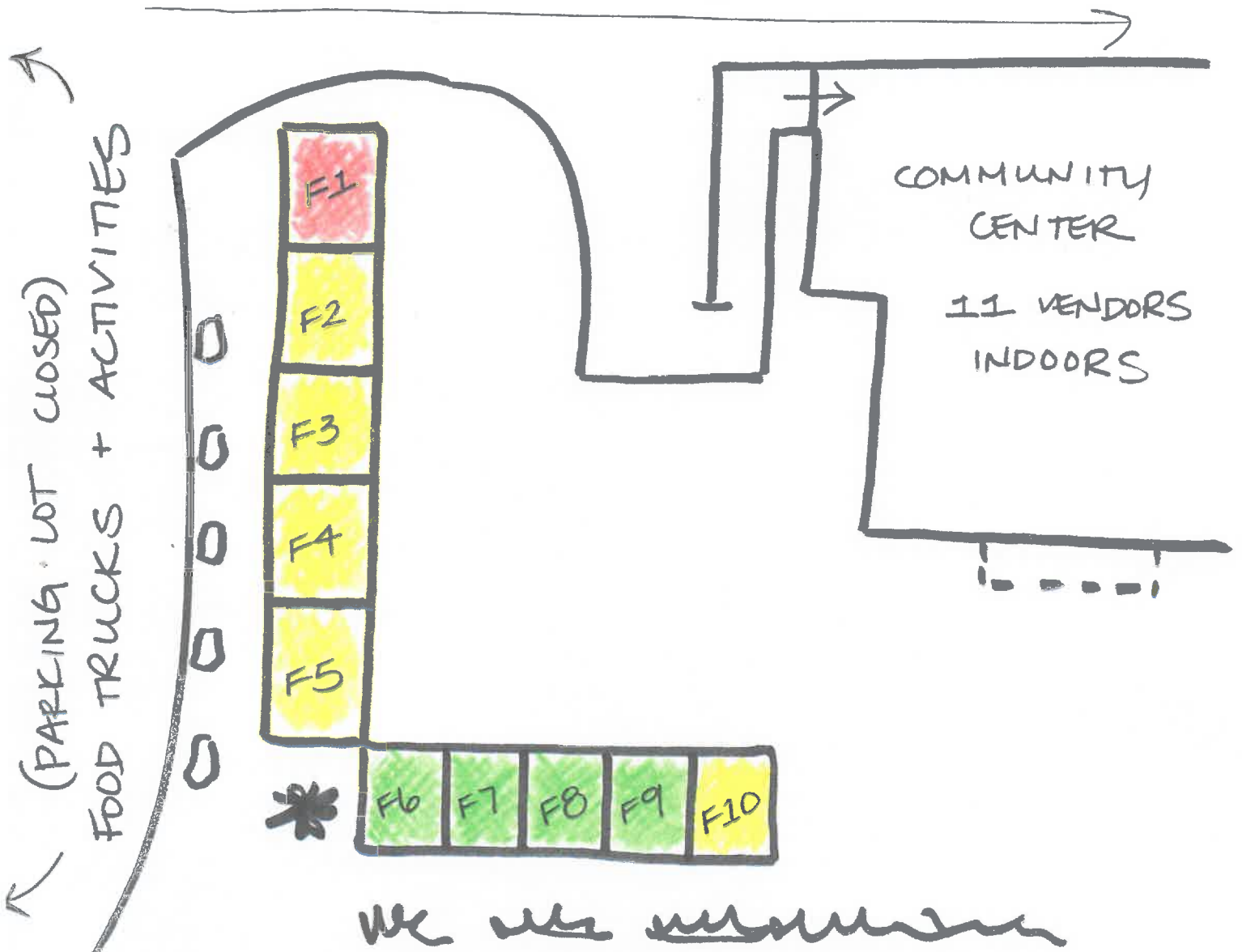

ROAD OPEN FOR EMERGENCY VEHICLES



-  = STANDARD (1 SIDE OPEN)
-  = PREMIUM (2 SIDES OPEN)
-  = DELUXE (3+ SIDES OPEN)

INDOORS @ COMM. CENTER

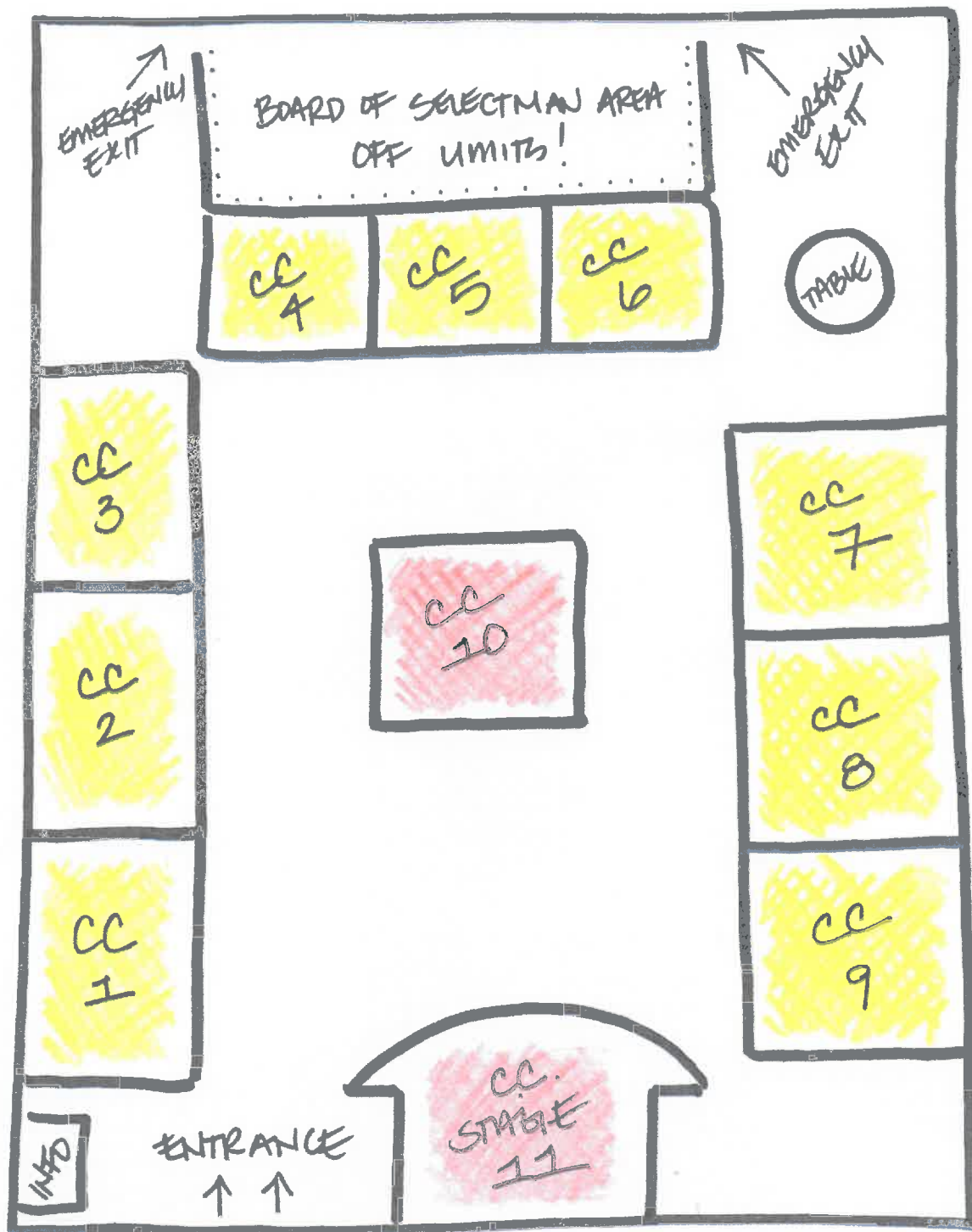

■ = PREMIUM

■ = DELUXE



Crescent St

ht St

20

54

69

Henniker Community Center

Layers

Google

Map data ©2023, Map data ©2023 United States Terms Privacy Send feedback 20 ft



HENNCOM-01

KMCCOMISH

CERTIFICATE OF LIABILITY INSURANCE

DATE (MM/DD/YYYY)

5/25/2023

THIS CERTIFICATE IS ISSUED AS A MATTER OF INFORMATION ONLY AND CONFERS NO RIGHTS UPON THE CERTIFICATE HOLDER. THIS CERTIFICATE DOES NOT AFFIRMATIVELY OR NEGATIVELY AMEND, EXTEND OR ALTER THE COVERAGE AFFORDED BY THE POLICIES BELOW. THIS CERTIFICATE OF INSURANCE DOES NOT CONSTITUTE A CONTRACT BETWEEN THE ISSUING INSURER(S), AUTHORIZED REPRESENTATIVE OR PRODUCER, AND THE CERTIFICATE HOLDER.

IMPORTANT: If the certificate holder is an ADDITIONAL INSURED, the policy(ies) must have ADDITIONAL INSURED provisions or be endorsed. If SUBROGATION IS WAIVED, subject to the terms and conditions of the policy, certain policies may require an endorsement. A statement on this certificate does not confer rights to the certificate holder in lieu of such endorsement(s).

PRODUCER Davis & Towle Group, Inc. PO Box 2300 Henniker, NH 03242	CONTACT NAME:		
	PHONE (A/C, No, Ext): (603) 428-3238	FAX (A/C, No):	
E-MAIL ADDRESS:			
INSURER(S) AFFORDING COVERAGE			NAIC #
INSURER A: Ohio Mutual Insurance Group			10202
INSURED Henniker Community Market c/o Monica Rico PO Box 2039 Henniker, NH 03242	INSURER B:		
	INSURER C:		
	INSURER D:		
	INSURER E:		
	INSURER F:		

COVERAGES CERTIFICATE NUMBER: REVISION NUMBER:

THIS IS TO CERTIFY THAT THE POLICIES OF INSURANCE LISTED BELOW HAVE BEEN ISSUED TO THE INSURED NAMED ABOVE FOR THE POLICY PERIOD INDICATED. NOTWITHSTANDING ANY REQUIREMENT, TERM OR CONDITION OF ANY CONTRACT OR OTHER DOCUMENT WITH RESPECT TO WHICH THIS CERTIFICATE MAY BE ISSUED OR MAY PERTAIN, THE INSURANCE AFFORDED BY THE POLICIES DESCRIBED HEREIN IS SUBJECT TO ALL THE TERMS, EXCLUSIONS AND CONDITIONS OF SUCH POLICIES. LIMITS SHOWN MAY HAVE BEEN REDUCED BY PAID CLAIMS.

INSR LTR	TYPE OF INSURANCE	ADDL INSD	SUBR WVD	POLICY NUMBER	POLICY EFF (MM/DD/YYYY)	POLICY EXP (MM/DD/YYYY)	LIMITS	
A	<input checked="" type="checkbox"/> COMMERCIAL GENERAL LIABILITY <input type="checkbox"/> CLAIMS-MADE <input checked="" type="checkbox"/> OCCUR GEN'L AGGREGATE LIMIT APPLIES PER: <input checked="" type="checkbox"/> POLICY <input type="checkbox"/> PRO-JECT <input type="checkbox"/> LOC OTHER:			CPP0030586	5/16/2023	5/16/2024	EACH OCCURRENCE	\$ 1,000,000
							DAMAGE TO RENTED PREMISES (Ea occurrence)	\$ 100,000
							MED EXP (Any one person)	\$ 5,000
							PERSONAL & ADV INJURY	\$ 1,000,000
							GENERAL AGGREGATE	\$ 2,000,000
							PRODUCTS - COMP/OP AGG	\$ 2,000,000
								\$
	AUTOMOBILE LIABILITY						COMBINED SINGLE LIMIT (Ea accident)	\$
	<input type="checkbox"/> ANY AUTO OWNED AUTOS ONLY <input type="checkbox"/> HIRED AUTOS ONLY <input type="checkbox"/> SCHEDULED AUTOS <input type="checkbox"/> NON-OWNED AUTOS ONLY						BODILY INJURY (Per person)	\$
							BODILY INJURY (Per accident)	\$
							PROPERTY DAMAGE (Per accident)	\$
								\$
	UMBRELLA LIAB						EACH OCCURRENCE	\$
	EXCESS LIAB						AGGREGATE	\$
	DED							\$
	RETENTION \$							\$
	WORKERS COMPENSATION AND EMPLOYERS' LIABILITY						PER STATUTE	OTH-ER
	ANY PROPRIETOR/PARTNER/EXECUTIVE OFFICER/MEMBER EXCLUDED? (Mandatory in NH)	Y/N	N/A				E.L. EACH ACCIDENT	\$
	If yes, describe under DESCRIPTION OF OPERATIONS below						E.L. DISEASE - EA EMPLOYEE	\$
							E.L. DISEASE - POLICY LIMIT	\$

DESCRIPTION OF OPERATIONS / LOCATIONS / VEHICLES (ACORD 101, Additional Remarks Schedule, may be attached if more space is required)
The Town of Henniker is hereby listed as an additional insured where it pertains to written contract

CERTIFICATE HOLDER Town of Henniker 18 Depot Hill Road Henniker, NH 03242	CANCELLATION SHOULD ANY OF THE ABOVE DESCRIBED POLICIES BE CANCELLED BEFORE THE EXPIRATION DATE THEREOF, NOTICE WILL BE DELIVERED IN ACCORDANCE WITH THE POLICY PROVISIONS.
	AUTHORIZED REPRESENTATIVE 

Hank Bernstein

From: Jim Morse

Sent:

To:

Cc:

Subject:

Looks good to me.

Jim

Get [Outlook for iOS](#)

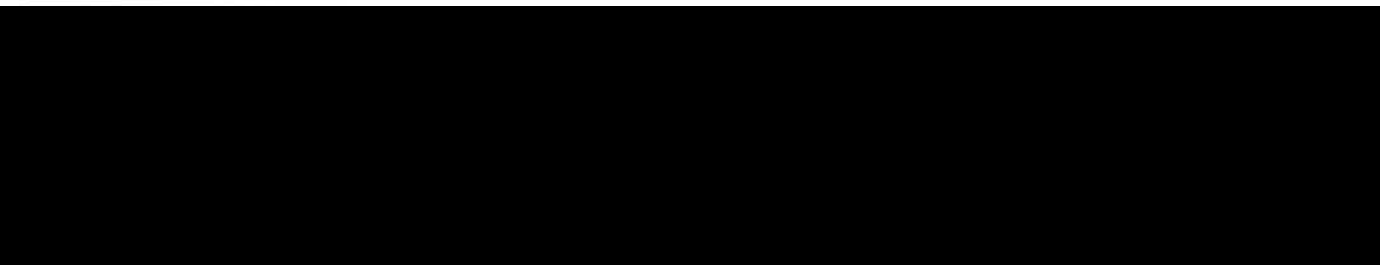

Subject: Special Event HHH

Good afternoon, Department Heads,

Monica Rico of Henniker Community Market has applied for a Special Event Permit for the Henniker Handmade and Homegrown event. Let us know if this has your approval or if you have any questions or comments.

Thank you,

Hank Bernstein
Town of Henniker
Land Use and General Administrative Assistant
hank.bernstein@hennikernh.gov
18 Depot Hill Rd.
Henniker, NH 03242
603-428-3221 ext. 2

Hank Bernstein

From:
Sent:
To:
Subject:

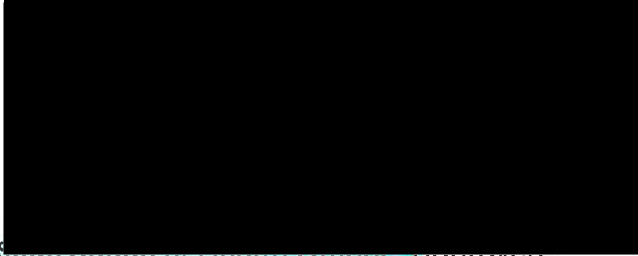

I see no issues for the Resale Equivalency Health Permit. Approved.

Thank you,
Greg

On Tue, Feb 13, 2024 at 2:08 PM Hank Bernstein <hank.bernstein@hennikernh.gov> wrote:

Good afternoon, Department Heads,

Monica Rico of Henniker Community Market has applied for a Special Event Permit for the Henniker Handmade and Homegrown event. Let us know if this has your approval or if you have any questions or comments.

Thank you,

Hank Bernstein

Town of Henniker

Land Use and General Administrative Assistant



18 Depot Hill Rd.

Henniker, NH 03242

603-428-3221 ext. 2

Hank Bernstein

From: [REDACTED] Bob Garside
Sent: Tuesday, February 13, 2024 2:21 PM
To: Hank Bernstein
Subject: Re: Special Event HHH

No issues

Sent from my iPhone

On Feb 13, 2024, at 2:07 PM, Hank Bernstein <hank.bernstein@hennikernh.gov> wrote:

Good afternoon, Department Heads,

Monica Rico of Henniker Community Market has applied for a Special Event Permit for the Henniker Handmade and Homegrown event. Let us know if this has your approval or if you have any questions or comments.

Thank you,

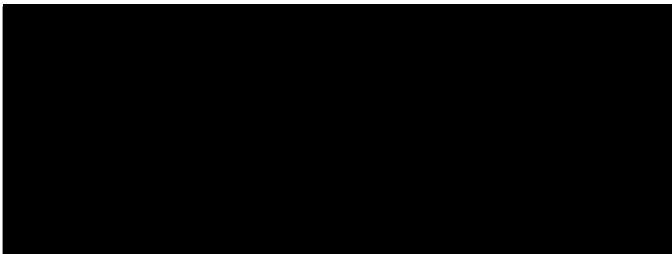

003-428-5221 ext. 2

<HHH 2023 Special Event App.pdf>

Helga Winn

From: Jim Donison
Sent: Wednesday, February 14, 2024 10:24 AM
To: Hank Bernstein; Bob Corrado; Jim Moran; Henniker Board; Leo Aucoin;
[REDACTED]
Cc: Helga Winn
Subject: RE: Special Event HHH

CSWW approves this application permit

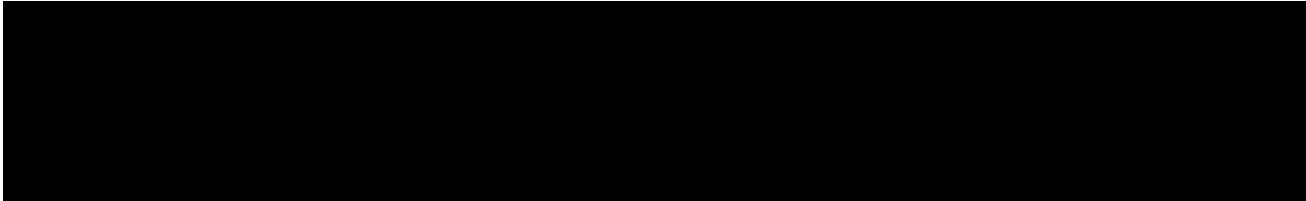

Cc: Helga Winn <helga.winn@hennikernh.gov>
Subject: Special Event HHH

Good afternoon, Department Heads,

Monica Rico of Henniker Community Market has applied for a Special Event Permit for the Henniker Handmade and Homegrown event. Let us know if this has your approval or if you have any questions or comments.

Thank you,

Hank Bernstein
Town of Henniker



10 Depot Hill Rd.
Henniker, NH 03242
603-428-3221 ext. 2

Helga Winn

From: Richard Slager
Sent: Wednesday, February 14, 2024 9:06 AM
To: Hank Bernstein; Bob Garside; Jim Morse; Henniker Rescue; Jim Donison; Leo Aucoin; [REDACTED]
Cc: Helga Winn
Subject: RE: Special Event HHH

Looks good to me also!

Richard "Rich" Slager
Wastewater superintendent
Work (603) 428-7215
Cell (603) 522-2215

From: Hank Bernstein <[REDACTED]>
Sent: Tuesday, February 13, 2024 2:17 PM

Subject: Special Event HHH

Good afternoon, Department Heads,

Monica Rico of Henniker Community Market has applied for a Special Event Permit for the Henniker Handmade and Homegrown event. Let us know if this has your approval or if you have any questions or comments.

Thank you,

Hank Bernstein
Town of Henniker
Land Use and General Administrative Assistant
[REDACTED]

18 Depot Hill Rd.
Henniker, NH 03242
603-428-3221 ext. 2

Hank Bernstein

From: Monica Rico <[REDACTED]>
Sent: Tuesday, February 13, 2024, 3:45 PM
To: Hank Bernstein
Cc: Helga Winn
Subject: Re: HHH Parking?

Hey Hank. What we've always done (and plan to do again) is have vendor parking at the Congregational church on Saturday and attendee parking at the Community School. Vendors park at the school on Sunday also. White Birch provides a shuttle service from the school. I have been placing No Parking signs along Main Street and will do so again. I'm not sure if that's detailed enough?

Monica

Sent from my iPhone

On Feb 13, 2024, at 3:45 PM, Hank Bernstein <[REDACTED]>

Howdy Monica,

Questions, comments, and approvals are coming in from the department heads. The Highway Superintendent has asked for a more detailed parking plan. He has also expressed concern about attendees parking on Main Street and would like you to include no parking signs as needed along Main Street. If you have any questions or if there is anything I can do to help, feel free to reach out.

Thank you,

Hank Bernstein
Town of Henniker

[REDACTED] Assistant

18 Depot Hill Rd.
Henniker, NH 03242
603-428-3221 ext. 2

Hank Bernstein

From: Monica Rico [REDACTED]
Sent: Tuesday, February 13, 2024 4:28 PM
To: Hank Bernstein
Cc: Helga Winn
Subject: Re: HHH Parking?

You could include that I will advertise parking at the community school on posters, social media, and also make signs.

Sent from my iPhone

On Feb 13, 2024, at 3:45 PM, Hank Bernstein <[REDACTED]>

Howdy Monica,

Questions, comments, and approvals are coming in from the department heads. The Highway Superintendent has asked for a more detailed parking plan. He has also expressed concern about attendees parking on Main Street and would like you to include no parking signs as needed along Main Street. If you have any questions or if there is anything I can do to help, feel free to reach out.

Thank you,

Hank Bernstein
Town of Henniker
Land Use and General Administrative Assistant

[REDACTED]
Henniker, NH 03242
603-428-3221 ext. 2

NEW BUSINESS



Town Hall
18 Depot Hill Road
Henniker, NH 03242

Tel: (603) 428-3221
Fax: (603) 428-4366

Incorporated November 10, 1768
"Only Henniker on Earth"

TOWN OF HENNIKER, NEW HAMPSHIRE

STAFF REPORT

DATE: 2/13/2024
TITLE: 2024 Truck and Truck Body Bid Approval
INITIATED BY: Leo Aucoin, Highway Superintendent
PREPARED BY: Leo Aucoin, Highway Superintendent
PRESENTED BY: Leo Aucoin, Highway Superintendent

AGENDA DESCRIPTION: Highway Department will be replacing truck # 605, 1006 yellow freightliner. Bid requests were posted and emailed to several dealers. Two truck bids were received as well as two bids for the body and plow. Bids are enclosed in this package. The Superintendent would like to purchase the International HX 520, the proposal from Reed Trucks. This is the same dealer that we purchased the previous truck from and does most of our out-of-shop service work. Service and parts supply were excellent. The dump body bid I would like to award to Donovan Company. Their bid best follows the bid specs. Donovan Company is only 45 minutes from the shop and has been servicing our trucks for many years and has been in business for over 75 years with an outstanding quality of workmanship. The other bidder is 2.5 hours away and on the last purchase of a truck body in 2022 we had several issues build that needed to be repaired, most of which we did ourselves because it was too far to drive the truck. Enclosed are the bids and warranty information and a steal comparison which are very important.

Legal Authority:

Financial Details:

Town Administrator Comment:

N/A

Suggested Action/Recommendation: The Superintendent of Highway would respectfully ask that the board except the bids and award the truck bid to Reed Truck and the body bid to Donovan Company, total amount of \$302,555.00.

Suggested Motion:

No formal action is required.



Hx520 SFA

Sales Proposal For:
TOWN OF HENNIKER

Presented By:
Reed Truck Services, Inc.

Prepared For:
Town of Henniker
Leo Auccin
18 Depot Hill Rd
Henniker, NH 03242-7368
(603)428-7200

Presented By:
Reed Truck Services, Inc.
Scott G. Reed
PO Box 989
Claremont, NH 03743
(603)542-5032

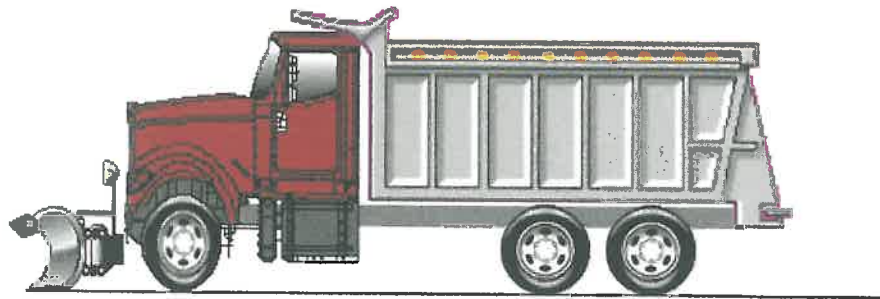

Model Profile
2025 HX520 SFA (HX520)

AXLE CONFIG:	6X4
MISSION:	Requested GVWR: 66000. Calc. GVWR: 66000. Calc. GCWR: 140000
DIMENSION:	Wheelbase: 213.00, CA: 123.00, Axle to Frame: 75.00
ENGINE, DIESEL:	{Cummins X15 500V} Productivity Series, EPA 2024, 500HP @ 1900 RPM, 1850 lb-ft Torque @ 900 RPM, 2000 RPM Governed Speed, 512 Peak HP (Max)
TRANSMISSION, AUTOMATIC:	{Allison 4700 RDS} 6th Generation Controls, 7 Speed with Double Overdrive, with PTO Provision, Less Retarder, Includes Oil Level Sensor, On/Off Highway, with Two Speed Reverse
CLUTCH:	Omit Item (Clutch & Control)
AXLE, FRONT NON-DRIVING:	{Meritor MFS-20-133A} Wide Track, I-Beam Type, 20,000-lb Capacity
AXLE, REAR, TANDEM:	{Meritor RT-46-164EH} Single Reduction, Standard Width, 46,000-lb Capacity, Driver Controlled Locking Differential in Forward-Rear and Rear-Rear Axle, 200 Wheel Ends Gear Ratio: 5.38
CAB:	Conventional, Day Cab
TIRE, FRONT:	(2) 315/80R22.5 Load Range L HAU 3 WT (CONTINENTAL), 480 rev/mile, 68 MPH, All-Position
TIRE, REAR:	(8) 12R22.5 Load Range H G622 RSD (GOODYEAR), 482 rev/mile, 75 MPH, Drive
SUSPENSION, REAR, TANDEM:	{Hendrickson HMX EX 460} Walking Beam, 46,000-lb Capacity, 54" Axle Spacing, Rubber Springs, with Transverse Torque Rods, Rubber End Bushings
PAINT:	Cab schematic 100LY Location 1: 2303, Red (Std) Chassis schematic N/A

<u>Code</u>	<u>Description</u>
HX52000	Base Chassis, Model HX520 SFA with 213.00 Wheelbase, 123.00 CA, and 75.00 Axle to Frame.
1AMR	CROSSMEMBER, FRAME TIE for Standard Duty
1AND	AXLE CONFIGURATION {Navistar} 6x4
	<u>Notes</u> : Pricing may change if axle configuration is changed.
1CGD	FRAME RAILS Heat Treated Alloy Steel (120,000 PSI Yield); 12.50" x 3.750" x 0.500" (317.5mm x 95.25mm x 12.7mm); 480.8" (12212mm) Maximum OAL
1LLW	BUMPER, FRONT Swept Back 40-Degrees, Steel, Painted, Heavy Duty
1WCP	FRAME EXTENSION, FRONT Integral; 27" in Front of Grille, Includes Crossmember for Front PTO
1WXD	WHEELBASE RANGE 211" (535cm) Through and Including 256" (650cm)
2ARY	AXLE, FRONT NON-DRIVING {Meritor MFS-20-133A} Wide Track, I-Beam Type, 20,000-lb Capacity
3ADJ	SUSPENSION, FRONT, SPRING Parabolic Taper Leaf, Shackle Type, 20,000-lb Capacity, Steel Springs 18K Capacity and (2) Rubber Auxiliary Springs 2K Capacity, Less Shock Absorbers
4091	BRAKE SYSTEM, AIR Dual System for Straight Truck Applications
	<u>Includes</u> : BRAKE LINES Color and Size Coded Nylon : PARKING BRAKE CONTROL Yellow Knob, Located on Instrument Panel : PARKING BRAKE VALVE For Truck : QUICK RELEASE VALVE On Rear Axle for Spring Brake Release: 1 for 4x2, 2 for 6x4 : SPRING BRAKE MODULATOR VALVE SR-7 with relay valve for 6x4/8x6
4619	TRAILER CONNECTIONS Four-Wheel, with Hand Control Valve and Tractor Protection Valve, for Straight Truck
4AZA	AIR BRAKE ABS {Bendix AntiLock Brake System} 4-Channel (4 Sensor/4 Modulator) Full Vehicle Wheel Control System
4EDM	AIR DRYER {Bendix AD-HF} with Heater, Includes Pressure Protection Circuits, Safety Valve, Integral Purge Tank, Governor Pressure Settings 110 psi Cut-In/130 psi Cut-Out, Integrated PuraGuard Coalescing Filtration
4EXU	BRAKE CHAMBERS, REAR AXLE {Bendix EverSure} 30/30 SqiIn Spring Brake
4EXV	BRAKE CHAMBERS, FRONT AXLE {Bendix} 24 SqiIn
4GBM	BRAKE, PARKING Manual Push-Pull Pneumatic Parking Brake
4LAG	SLACK ADJUSTERS, FRONT {Gunitite} Automatic
4LGG	SLACK ADJUSTERS, REAR {Gunitite} Automatic
4SPA	AIR COMPRESSOR {Cummins} 18.7 CFM

<u>Code</u>	<u>Description</u>
4VGN	AIR TANK Painted Aluminum, with Straight Thread O-Ring Ports
4VKC	AIR DRYER LOCATION Mounted Inside Left Rail, Back of Cab
4WBX	DUST SHIELDS, FRONT BRAKE for Air Cam Brakes
4WDM	DUST SHIELDS, REAR BRAKE for Air Cam Brakes
4WXR	DRAIN VALVE (2) {Berg} with Pull Chains, for Air Tanks
4WZJ	AIR TANK LOCATION (2) : One Mounted Under Each Rail, Front of Rear Suspension, Parallel to Rail
4XDR	BRAKES, REAR {Meritor 16.5X7 Q-PLUS CAST} Air S-Cam Type, Cast Spider, Fabricated Shoe, Double Anchor Pin, Size 16.5" X 7", 23,000-lb Capacity per Axle
4XDT	BRAKES, FRONT {Meritor 16.5X6 Q-PLUS CAST} Air S-Cam Type, Cast Spider, Fabricated Shoe, Double Anchor Pin, Size 16.5" X 6", 23,000-lb Capacity
4XEE	PARK BRAKE CHAMBERS, ADDITIONAL (2) Spring Brake Type
5710	STEERING COLUMN Tilting and Telescoping
5CAW	STEERING WHEEL 4-Spoke; 18" Dia., Black
5PUB	STEERING GEAR (2) {Sheppard M100/HD94} Dual Power
6DGX	DRIVELINE SYSTEM {Dana Spicer} Service Free SPL250 Main Driveline with SPL170 Interaxle Shaft, for 6x4
7BEU	AFTERTREATMENT COVER Aluminum
7BLY	EXHAUST SYSTEM Horizontal Aftertreatment System, Frame Mounted Right Side Under Cab, for Single Vertical Tail Pipe, Cab Mounted Right Side
7SAP	ENGINE COMPRESSION BRAKE {Cummins} Interbrake For Cummins Signature/ISX/ X15 Engines; Furnished with Engine
7WBA	TAIL PIPE (1) Turnback Type, Bright
7WDM	EXHAUST HEIGHT 10'
7WDN	MUFFLER/TAIL PIPE GUARD (1) Aluminum
7WZX	SWITCH, FOR EXHAUST 3 Position, Momentary, Lighted Momentary, ON/CANCEL, Center Stable, INHIBIT REGEN, Mounted in IP Inhibits Diesel Particulate Filter Regeneration When Switch is Moved to ON While Engine is Running, Resets When Ignition is Turned OFF
8000	ELECTRICAL SYSTEM 12-Volt, Standard Equipment

Includes

- : HAZARD SWITCH Push On/Push Off, Located on Instrument Panel to Right of Steering Wheel
- : HEADLIGHT DIMMER SWITCH Integral with Turn Signal Lever
- : PARKING LIGHT Integral with Front Turn Signal and Rear Tail Light
- : STARTER SWITCH Electric, Key Operated

<u>Code</u>	<u>Description</u>
	: STOP, TURN, TAIL & B/U LIGHTS Dual, Rear, Combination with Reflector
	: WINDSHIELD WIPER SWITCH 2-Speed with Wash and Intermittent Feature (5 Pre-Set Delays), Integral with Turn Signal Lever
	: WINDSHIELD WIPERS Single Motor, Electric, Cowl Mounted
8541	HORN, ELECTRIC (2) Disc Style
8585	FOG LIGHTS Prewire; Includes Auxiliary Switch and Wiring to Front Bumper, for Driving Lights or Fog Lights Mounted by Customer
8836	HORN, AIR (2) Single Bell, Organ Tone, Extra Long, Chrome
8899	JUMP START STUD (2) Remote Mounted
8ACE	BEACON LIGHT WIRING for (2) Customer Installed Beacons, Includes 2-Way Switch
8GXJ	ALTERNATOR {Leece-Neville AVI160P2013} Brush Type, 12 Volt, 160 Amp Capacity, Pad Mount
8HAU	BODY BUILDER WIRING INSIDE CAB; Includes Sealed Connectors for Tail/Amber, Turn/Marker/Backup/Accessory, Power/Ground, and Stop/Turn
8MMZ	BATTERY SYSTEM {Fleetrite AGM-GP31} Maintenance-Free, (3) AGM 12-Volt 2475CCA Total, Top Threaded Stud
8RBZ	SPEAKER, AUXILIARY, CB RADIO with Jack for CB; Mounted Left Side Above Driver's Door
8RGA	2-WAY RADIO Wiring Effects; Wiring with 20 Amp Fuse Protection, Includes Ignition Wire with 5 Amp Fuse, Wire Ends Heat Shrink and Routed to Center of Header Console in Cab
8RMW	SPEAKERS (2) 6.5" Coax Mounted in Doors, (2) 5.25" Coax Mounted in B-Pillars
8RNB	CB RADIO Accommodation Package, Header Mounted, Feeds from Accessory Side of Ignition Switch, Includes Power Source, One Antenna and Antenna Base with Wiring on Left Side Mirror
8RPR	ANTENNA for Increased Roof Clearance Applications
8RPS	RADIO AM/FM/WB/Clock/Bluetooth/USB Input/Auxiliary Input
8TME	TRAILER CONNECTION SOCKET {Phillips} 7-Way, Mounted at Rear of Frame, Wired for Turn Signals Independent of Stop, Compatible with Trailers with Amber or Side Turn Lamps
8TNP	AUXILIARY HARNESS 5.0' for Auxiliary Front Head Lights and Turn Signals for Front Plow Applications
8WEZ	TURN SIGNAL SWITCH Self-Canceling
8WRB	HEADLIGHTS ON W/WIPERS Headlights Will Automatically Turn On if Windshield Wipers are Turned On
8WXB	HEADLIGHT WARNING BUZZER Sounds When Head Light Switch is on and Ignition Switch is in "Off" Position
8WXD	ALARM, PARKING BRAKE Electric Horn Sounds in Repetitive Manner When Vehicle Park Brake is "NOT" Set, with Ignition "OFF" and any Door Opened

<u>Code</u>	<u>Description</u>
8WXG	STARTING MOTOR {Mitsubishi Electric Automotive America 105P} 12-Volt, with Soft-Start
8WZG	JUNCTION BLOCK Stud, 100 Amp Battery Feed, Protected by a Fusible Link, Stud to Be Used for Body Builder Feeds Inside Cab
8XAH	CIRCUIT BREAKERS Manual-Reset (Main Panel) SAE Type III with Trip Indicators, Replaces All Fuses
8XDZ	BATTERY BOX Steel, 2-3 Battery Capacity, Mounted Inside the Cab, Under Passenger Seat
8XJC	BATTERY WIRING MODIFICATION Battery Discharge Protection System; Control thru Body Controller
8XKC	HEADLIGHTS Halogen, with Daytime Running Lights, Automatic Twilight Controlled
8XLW	LIGHT, WORK LED, Pedestal Mounted, Back of Cab, with Switch on Instrument Panel
8XNB	BATTERY DISCONNECT SWITCH 300 Amp, Disconnects Power to Power Distribution Center (PDC), Does Not Disconnect Charging Circuits, Locks with Padlock, Cab Mounted
9AAB	LOGOS EXTERIOR Model Badges
9AAE	LOGOS EXTERIOR, ENGINE Badges
9ASE	FRONT END Tilting, Composite
9HCN	GRILLE Chrome Vertical Accent Bars, with Black Mesh
10060	PAINT SCHEMATIC, PT-1 Single Color, Design 100
10761	PAINT TYPE Base Coat/Clear Coat, 1-2 Tone
10AGB	COMMUNICATIONS MODULE Telematics Device with Over the Air Programming; Includes Five Year Data Plan and International 360
10SLV	PROMOTIONAL PACKAGE Government Silver Package
10WLC	GCWR RANGE GCWR Equal to or Less than 80,000-lb, Higher GCWR May Result in Reduced Engine Performance While Operating in Extreme Hot Weather Conditions
11001	CLUTCH Omit Item (Clutch & Control)
12703	ANTI-FREEZE Red, Extended Life Coolant; To -40 Degrees F/ -40 Degrees C, Freeze Protection
12851	PTO EFFECTS, ENGINE FRONT Less PTO Unit, Includes Adapter Plate on Engine Front Mounted
12EWZ	ENGINE, DIESEL {Cummins X15 500V} Productivity Series, EPA 2024, 500HP @ 1900 RPM, 1850 lb-ft Torque @ 900 RPM, 2000 RPM Governed Speed, 512 Peak HP (Max)
12THT	FAN DRIVE {Horton Drivemaster} Two-Speed Type, Direct Drive, with Residual Torque Device for Disengaged Fan Speed
	<u>Includes</u> : FAN Nylon

<u>Code</u>	<u>Description</u>
12VCC	AIR CLEANER Single Element, with Integral Pre-Cleaner, Integral Snow Valve and In-Cab Control, Engine Mounted
12VJT	EMISSION, CALENDAR YEAR {Cummins X15} EPA, OBD and GHG Certified for Calendar Year 2024
12VYL	ACCESSORY WIRING, SPECIAL for Road Speed Wire Coiled Under Instrument Panel for Customer Use
12WBR	FAN OVERRIDE Manual; with Electric Switch on Instrument Panel, (Fan On with Switch On)
12WCT	BLOCK HEATER, ENGINE {Phillips} 120V/1500W, with "Y" Cord for Fuel Heater <u>Includes</u> : BLOCK HEATER SOCKET Receptacle Type; Mounted below Drivers Door
12WGA	HOSE CLAMPS, RADIATOR HOSES , Mechanical Type; with Constant-Tension Functionality
12WTA	FAN DRIVE SPECIAL EFFECTS Fan Cooling Ring with Fan Shroud Effects, Engine Mounted
12WWG	EPA IDLE COMPLIANCE Low NOx Idle Engine, Complies with EPA Clean Air Regulations; Includes "Certified Clean Idle" Decal on Hood
12WYZ	RADIATOR DRAIN & FILL FITTING SPECIAL; To Vacuum Out or Fill the Cooling System from the Bottom of Radiator, for Use with Quick-Connect Radiator Drain Tool or Shop Coolant Evacuation-Fill System
12WZE	CARB IDLE COMPLIANCE Does Not Comply with California Clean Air Idle Regulations
12XBN	RADIATOR Aluminum, Welded, Cross Flow, Front to Back System, 1084 SqIn, with 866 SqIn Charge Air Cooler <u>Includes</u> : RADIATOR HOSES Premium, Rubber
12XCS	CARB EMISSION WARR COMPLIANCE Does Not Comply with CARB Emission Warranty
13BES	TRANSMISSION, AUTOMATIC {Allison 4700 RDS} 6th Generation Controls, 7 Speed with Double Overdrive, with PTO Provision, Less Retarder, Includes Oil Level Sensor, On/Off Highway, with Two Speed Reverse
13WCT	OIL COOLER, TRANSMISSION {Champ} Remote Mounted, for Automatic Transmission
13WEH	AUTOMATIC NEUTRAL Allison Transmission Shifts to Neutral When Parking Brake is Engaged and Remains in Neutral When Parking Brake is Disengaged, without On/Off Switch
13WET	TRANSMISSION SHIFT CONTROL Column Mounted Stalk Shifter, Not for Use with Allison 1000 & 2000 Series Transmission
13WLM	TRANSMISSION OIL Synthetic; 63 thru 76 Pints

<u>Code</u>	<u>Description</u>
13WUS	ALLISON SPARE INPUT/OUTPUT for Rugged Duty Series (RDS) and Regional Haul Series (RHS), General Purpose Trucks, Package Number 223, Modified for Single Input Auto Neutral
13WYU	SHIFT CONTROL PARAMETERS {Allison} 3000 or 4000 Series Transmissions, Performance Programming
14HRC	AXLE, REAR, TANDEM {Meritor RT-46-164EH} Single Reduction, Standard Width, 46,000-lb Capacity, Driver Controlled Locking Differential in Forward-Rear and Rear-Rear Axle, 200 Wheel Ends . Gear Ratio: 5.38
	<u>Notes</u> : Axle Lead Time is 45 Days
14UMX	SUSPENSION, REAR, TANDEM {Hendrickson HMX EX 460} Walking Beam, 46,000-lb Capacity, 54" Axle Spacing, Rubber Springs, with Transverse Torque Rods, Rubber End Bushings
14WCR	TRANSVERSE TORQUE RODS {Hendrickson} TRAAX Rod, Transverse Only
15924	FUEL TANK STRAPS Bright Finish Stainless Steel
15LNA	FUEL HEATER {Cummins} Plumbing for Thermal Recirculation Valve (TRV) Mounted to Cummins X15 Engines, Thermostatically Controlled
15LRV	FUEL/WATER SEPARATOR {Davco 386} 120 VAC Plug-In Electric Pre-Heater, 12 VDC Electric Heater, with ESOC Fittings, Includes Water-in-Fuel Sensor
15SGL	FUEL TANK Non-Polished Aluminum, 24" Dia, 80 US Gal (303L), Mounted Left Side, Under Cab
15WEY	DEF TANK 10.8 US Gal (41L) Capacity, Frame Mounted Outside Left Rail, Under Cab
16030	CAB Conventional, Day Cab
	<u>Includes</u> : CAB REAR SUSPENSION Air : CLEARANCE/MARKER LIGHTS (5) LED Roof Mounted : COAT HOOK, CAB Located on Rear Wall, Centered Above Rear Window : CONSOLE, CENTER Includes Two Cup Holders and One Additional Storage Area : CONSOLE, OVERHEAD Molded Plastic with Dual Storage Pockets, Retainer Nets and CB Radio Pocket; Located Above Driver and Passenger : COURTESY LIGHT (2) Driver and Passenger Door Mounted : DOME LIGHT, CAB Rectangular, Door and Instrument Panel Mounted Switch Activated, Timed Theater Dimming, Center Mounted, Integral to Console : FLOOR COVERING Rubber, Black : GLASS, ALL WINDOWS Tinted : GRAB HANDLE, CAB INTERIOR (1) "A" Pillar Mounted, Passenger Side : GRAB HANDLE, CAB INTERIOR (4) "B" Pillar and Door Mounted, Two Each Side : READING LIGHT, CAB Located in Overhead Console : STORAGE POCKET, DOOR (2) Full Length, Driver and Passenger Door
16BAM	AIR CONDITIONER with Integral Heater and Defroster

<u>Code</u>	<u>Description</u>
	<u>Includes</u> : HOSE CLAMPS, HEATER HOSE Mubea Constant Tension Clamps
16GEG	GAUGE CLUSTER Premium Level; English with English Electronic Speedometer <u>Includes</u> : GAUGE CLUSTER DISPLAY: Base Level (3" Monochromatic Display), Premium Level (5" LCD Color Display); Odometer, Voltmeter, Diagnostic Messages, Gear Indicator, Trip Odometer, Total Engine Hours, Trip Hours, MPG, Distance to Empty/Refill for : GAUGE CLUSTER Speedometer, Tachometer, Engine Coolant Temp, Fuel Gauge, DEF Gauge, Oil Pressure Gauge, Primary and Secondary Air Pressure : WARNING SYSTEM Low Fuel, Low DEF, Low Oil Pressure, High Engine Coolant Temp, Low Battery Voltage (Visual and Audible), Low Air Pressure (Primary and Secondary)
16HKT	IP CLUSTER DISPLAY On Board Diagnostics Display of Fault Codes in Gauge Cluster
16LWL	SEAT, DRIVER {ISRI} Series 300, Air Suspension, High Back, Mordura, Single Chamber Lumbar, Inboard Armrest, Suspension Cover, Fore/Aft Isolator, Cushion Extension, Seat Tilt
16SDC	GRAB HANDLE, EXTERIOR (2) Chrome, Towel Bar Type, with Anti-Slip Rubber Inserts, for Cab Entry Mounted Left and Right Side at B-Pillar
16SMZ	SEAT, PASSENGER {Seats, Inc.} Non Suspension, High Back, Fixed Back, Integral Headrest, Mordura Cloth, for use with Batteries in Cab
16SNR	MIRRORS (2) C-Loop, Power Adjust, Heated, LED Clearance Lights, Bright Heads and Arms, 7.5" x 14" Flat Glass, Includes 7.5" x 7" Convex Mirrors, for 102" Load Width <u>Notes</u> : Mirror Dimensions are Rounded to the Nearest 0.5"
16SNY	MIRROR, CONVEX, HOOD MOUNTED (2) Right and Left Sides, Bright, 7.5" x 7"
16VKK	CAB INTERIOR TRIM Diamond, for Day Cab
16VLV	MONITOR, TIRE PRESSURE Omit
16VSL	WINDSHIELD Heated, Single Piece
16WHJ	HOSE CLAMPS, HEATER HOSE {Breeze} Belleville Washer Type
16WJU	WINDOW, POWER (2) and Power Door Locks, Left and Right Doors, Includes Express Down Feature
16XBZ	MODESTY PANEL Painted Body Color, with Amber Lens LED Lights, for Day Cab
16XJP	INSTRUMENT PANEL Wing Panel
16XTM	ACCESS, CAB Aluminum, Driver & Passenger Sides, Two Steps per Door, for use with Day Cab or Sleeper Cab
16XWE	SUNSHADE, EXTERIOR Bright Finish, with Integral Clearance/Marker Lights
16XWJ	WINDSHIELD WIPER BLADES Winter Type

<u>Code</u>	<u>Description</u>
27DUT	WHEELS, FRONT {Alcoa 89U63} DISC; 22.5x9.00 Rims, Mirror Polish Aluminum, 10-Stud, 285.75mm BC, Hub-Piloted, Flanged Nut, with Steel Hubs, Non-Standard Offset 4.06"
28DWR	WHEELS, REAR {Accuride 43644} DUAL DISC; 22.5x8.25 Rims, Standard Polish Aluminum, 10-Stud, 285.75mm BC, Hub-Piloted, Flanged Nut, with Steel Hubs
60AAG	BDY INTG, REMOTE POWER MODULE Mounted Inside Cab Behind Driver Seat, Up to 6 Outputs & 6 Inputs, Max 20 amp per Channel, Max 80 amp Total; Includes 1 Switch Pack with Latched Switches
7382158102	(8) TIRE, REAR 12R22.5 Load Range H G622 RSD (GOODYEAR), 482 rev/mile, 75 MPH, Drive
7792545437	(2) TIRE, FRONT 315/80R22.5 Load Range L HAU 3 WT (CONTINENTAL), 480 rev/mile, 68 MPH, All-Position
	Services Section:
40132	WARRANTY Standard for HX520, HX620, Effective with Vehicles Built January 1, 2021 or Later, CTS-2015B

(US DOLLAR)

Description

Price

Net Sales Price:

\$177,900.00

Please feel free to contact me regarding these specifications should your interests or needs change. I am confident you will be pleased with the quality and service of an International vehicle.

Approved by Seller:

Accepted by Purchaser:

Official Title and Date

Firm or Business Name

Authorized Signature

Authorized Signature and Date

This proposal is not binding upon the seller without Seller's Authorized Signature

Official Title and Date

The TOPS FET calculation is an estimate for reference purposes only. The seller or retailer is responsible for calculating and reporting/paying appropriate FET to the IRS.

The limited warranties applicable to the vehicles described herein are Navistar, Inc.'s standard printed warranties which are incorporated herein by reference and to which you have been provided a copy and hereby agree to their terms and conditions.

Cab and Chassis

- Price includes right side Timbren Auxiliary Spring for wing.
- Price includes standard warranty (See Attached)
- Allison 4700 Transmission has 3 Year Warranty Included, 5 & 7 Year available.

TOTAL BID PRICE: \$177,900.00

Many Extended Warranty Options Available.

Price includes: 500 HP Cummins Engine

Batteries in Cab - Deduct (\$2,000.00 in not required)



KEY FEATURES:

- ▶ Cummins ISX15 up to 600 HP / 2,050 lb.-ft. of torque
- ▶ Standard all metal grille with bright surround and bright grille bars
- ▶ Available dual external air cleaners deliver heavy duty filtration, easy maintenance and long service life
- ▶ The Metton hood provides excellent visibility, superior strength and impressive durability
- ▶ Available bright sun visor, cab skirt and bug deflectors provide functional good looks that last
- ▶ Available, industry-leading 12.5" x 0.5" single frame rail delivers 3.5 million RBM while reducing corrosion
- ▶ Standard Huck-Spin frame and crossmember fasteners deliver superior clamping force that lasts
- ▶ Available 150,000 lb. capacity center tow pin provides assured strength in extreme recovery scenarios

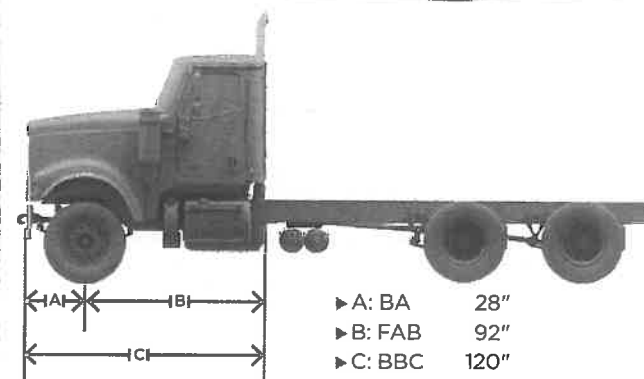

- ▶ A: BA 28"
- ▶ B: FAB 92"
- ▶ C: BBC 120"

120" BBC SET-FORWARD FRONT AXLE

GVWR

- ▶ 52,000 - 92,000 lbs.

Hood Design

- ▶ Long Square Metton Hood

Axle Configurations

- ▶ 6x4
- ▶ 8x6

Frames

- ▶ Yield: 120,000 PSI
- ▶ RBM: 2,037,600 - 4,450,000 in.-lbs.
- ▶ SM: 16.98 - 37.08 cu. in.

Engine

- ▶ Cummins ISX15:
 - HP: 450 - 600
 - Torque: 1,650 - 2,050 lb.-ft.

Transmission

- ▶ Manual: Eaton 8LL - 18-speed
- ▶ Automated: Eaton UltraShift+ VMS, VCS, MXP, VXP
- ▶ Automatic: Allison 4000, 4500, 4700 Series

Front Axles

- ▶ Meritor: 12,000 - 20,000 lbs.
- ▶ Dana: 16,000 - 20,000 lbs.

Front Suspensions

- ▶ Multi-Leaf: 20,000 lbs.
- ▶ Parabolic: 12,000 - 20,000 lbs.

Rear Axles

- ▶ Dana Tandem:
 - Single Speed: 40,000 - 46,000 lbs.
 - Two Speed: 46,000 lbs.
- ▶ Meritor Tandem: 40,000 - 70,000 lbs.
 - Double Reduction: 58,000 - 70,000 lbs.
 - Tridem: 53,000 - 69,000 lbs.

Rear Suspensions

- ▶ Chalmers: 40,000 - 52,000 lbs.
- ▶ Hendrickson RT: 40,000 - 65,000 lbs, RS: 65,000 lbs, R: 80,000 lbs.
- ▶ Hendrickson HMX: 40,000 - 46,000 lbs.
- ▶ Hendrickson HAS: 40,000 - 46,000 lbs.
- ▶ Hendrickson PRIMAX®: 46,000 - 52,000 lbs.
- ▶ Hendrickson PAX Tridem: 69,000 lbs.

Exhaust

- ▶ Switchback After Treatment Device: Single or Dual Vertical Stacks
- ▶ Vertical After Treatment Device: Single Vertical Stack

Electrical

- ▶ Alternator:
 - Bosch: 160 - 200 Amp.
 - Delco Remy: 165 - 300 Amp.
 - Leece-Neville: 210 - 240 Amp.
- ▶ Batteries
 - 1,950 - 3,700 CCAs

Fuel Tanks

- ▶ 60 - 240 Gallons, Single or Dual, Polished or Non-Polished
- ▶ LH Mounted Under Cab or Dual Under Cab or Back of Cab
- ▶ 24" or 26" Diameter

Braking and Control Systems

- ▶ Traction Control
- ▶ Electronic Stability Control (ESP)
- ▶ Bendix® Wingman®*

Available Recovery Devices

- ▶ Center Tow Pin: 150,000 lbs.
- ▶ Tow Hooks: 80,000 lbs.
- ▶ HD Rear Tow Loop: 80,000 lbs.
- ▶ HD Rear Tow Hooks: 80,000 lbs.

*Available via custom engineering

Note: The information and conclusions contained are believed to be correct at time of publication, but do not necessarily apply to similar vehicles with different specifications or with production dates after the production of this publication. Vehicles with different specifications or later dates of production may yield different results. Vehicle specifications are subject to change without notice. TAD16003 02/2016 ©2016 NAVISTAR Inc. All rights reserved. All marks are trademarks of their respective owners.

HX520



Configuration: Long Hood Set-Forward Axle
Application: Truck or Tractor
Engine: Cummins ISX15



- ▶ HEAVY HAUL TRACTOR
- ▶ CONSTRUCTION DUMP
- ▶ LOGGING
- ▶ RECOVERY

Whether you're moving fresh-cut timber, transporting bulk aggregate or hauling heavy equipment, the HX520 is built to carry the load. With the relentless power of the Cummins ISX15 and your choice of double reduction or tridem rear axles up to 70,000 lbs., you know the HX520 has the muscle for the job. The HX520 is built to sustain whatever comes its way, and extensively tested to move you to the head of the class.



SPECIFICATIONS

Henniker Highway Department
Henniker, New Hampshire

Truck Chassis 2024 specifications

January 19, 2024

Prepared For:

Town of Henniker
Leo Aucoin
18 Depot Hill Rd.
Henniker, NH 03242
(603)428-7200



AXLE CONFIG:	6X4
MISSION:	Requested GVWR: 66000. Calc. GVWR: 66000
DIMENSION:	Wheelbase: 215.00, CA: 125.00, Axle to Frame: 75.00
ENGINE, DIESEL:	{Cummins X15 470 V} Productivity Series, EPA 2021, 470HP @ 1900 RPM, 1750 lb-ft Torque @ 950 RPM, 2000 RPM Governed Speed, 482 Peak HP (Max)
TRANSMISSION AUTOMATIC:	{Allison 4700 RDS} 5th Generation Controls, 7 Speed with Double Overdrive, with PTO Provision, Less Retarder, Includes Oil Level Sensor, On/Off Highway, with Two Speed Reverse
CLUTCH:	Omit Item (Clutch & Control)
AXLE, FRONT NON-DRIVING:	{Meritor MFS-20-133A} Wide Track, I-Beam Type, 20,000-lb Capacity
AXLE, REAR, TANDEM:	{Meritor RT-46-164EH} Single Reduction, Standard Width, 46,000-lb Capacity, Driver Controlled Locking Differential in Forward-Rear and Rear-Rear Axle, 200 Wheel Ends Gear Ratio: 5.38
CAB:	Conventional, Day Cab
TIRE, FRONT:	(2) 315/80R22.5 Load Range L G289 WHA (GOODYEAR), 484 rev/mile, 68 MPH, All-Position
TIRE, REAR:	(8) 11R22.5 Load Range H ARMOR MAX MSD (GOODYEAR), 493 rev/mile, 68 MPH, Drive
SUSPENSION, REAR, TANDEM:	{Chalmers 854-46H} Walking Beam, 46,000-lb Capacity, 54" Axle Spacing, Rubber Springs, with (8) Torque Rods, Restrictor Cans

Prepared by:
Troy Merwin
ATG MANCHESTER LLC
220 FRONTAGE RD.
MANCHESTER, NH 03103
Phone: (603) 668-1700

A proposal for

Prepared by
ATG MANCHESTER LLC
Troy Merwin

Feb 06, 2024

Western Star 49X

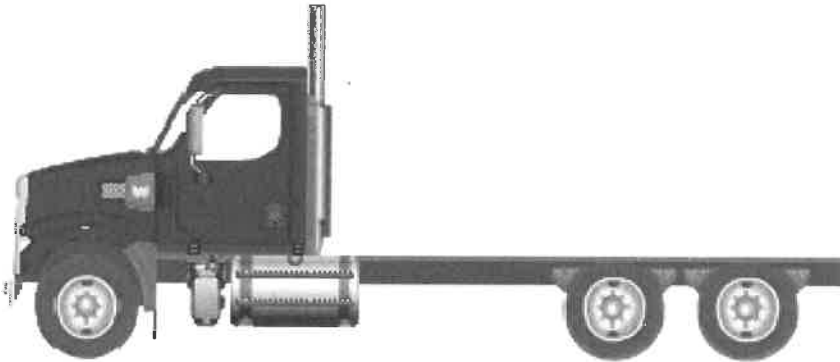

Components shown may not reflect all spec'd options and are not to scale

S P E C I F I C A T I O N P R O P O S A L

Data Code	Description	Weight Front	Weight Rear	Retail Price
Price Level				
PRL-28X	WST 47X/49X PRL-28X (EFF:MY25 ORDERS)			STD
Data Version				
DRL-027	SPECPRO21 DATA RELEASE VER 027			N/C
Vehicle Configuration				
001-472	WESTERN STAR 49X	9,175	6,500	\$217,958.00
004-225	2025 MODEL YEAR SPECIFIED			STD
002-003	SET FORWARD AXLE - TRUCK	-600	600	N/C
019-006	TRAILER TOWING PROVISION AT END OF FRAME WITH SAE J560	10	10	N/C
003-001	LH PRIMARY STEERING LOCATION			STD
General Service				
AA1-003	TRUCK/TRAILER CONFIGURATION			N/C
AA6-001	DOMICILED, USA 50 STATES (INCLUDING CALIFORNIA AND CARB OPT-IN STATES)			STD
99D-019	CARB EMISSIONS CERTIFICATION NOT FOR INITIAL REGISTRATION IN CALIFORNIA AND CARB OPT-IN STATES -CARB CLEAN IDLE (6X4 INCH LABEL ON LOWER FORWARD DRIVER DOOR)			\$112.00
AF2-998	NONE			N/C
A85-011	CONSTRUCTION SERVICE			STD
A84-1GM	GOVERNMENT BUSINESS SEGMENT			N/C
AA4-010	DIRT/SAND/ROCK COMMODITY			STD
AA5-002	TERRAIN/DUTY: 100% (ALL) OF THE TIME, IN TRANSIT, IS SPENT ON PAVED ROADS			STD
AB1-008	MAXIMUM 8% EXPECTED GRADE			STD
AB5-001	SMOOTH CONCRETE OR ASPHALT PAVEMENT - MOST SEVERE IN-TRANSIT (BETWEEN SITES) ROAD SURFACE			STD
995-1A5	WESTERN STAR VOCATIONAL WARRANTY			STD
A66-99D	EXPECTED FRONT AXLE(S) LOAD : 20000.0 lbs			

Prepared by:
 Troy Merwin
 ATG MANCHESTER LLC
 220 FRONTAGE RD.
 MANCHESTER, NH 03103
 Phone: (603) 668-1700

Data Code	Description	Weight Front	Weight Rear	Retail Price
A68-99D	EXPECTED REAR DRIVE AXLE(S) LOAD : 46000.0 lbs			
A63-99D	EXPECTED GROSS VEHICLE WEIGHT CAPACITY : 66000.0 lbs			
A70-99D	EXPECTED GROSS COMBINATION WEIGHT : 80000.0 lbs			
Truck Service				
AA3-018	FRONT PLOW/END DUMP BODY			N/C
AF3-2A4	TENCO USA, INC.			N/C
Tractor Service				
AA2-005	FLATBED TRAILER			N/C
AH6-001	SINGLE (1) TRAILER			N/C
Engine				
101-3H9	CUM X15 470V HP @ 1900 RPM, 2000 GOV RPM, 1750 LB-FT @ 900 RPM	150	60	\$1,239.00
Electronic Parameters				
N	79A-075	75 MPH ROAD SPEED LIMIT		STD
	79B-000	CRUISE CONTROL SPEED LIMIT SAME AS ROAD SPEED LIMIT		N/C
	79K-013	PTO MODE ENGINE RPM LIMIT - 1600 RPM		STD
	79P-032	PTO RPM CONTROL WITH STEERING WHEEL SWITCHES		N/C
	79W-024	CRUISE CONTROL BUTTON PTO CONTROL		N/C
	79X-023	PTO SPEED 1 SETTING - 600 RPM		N/C
	80E-001	ENGINE FAN ENABLED WITH RETARDER		N/C
	80F-001	AUTOMATIC OIL LIFE MONITOR WITH ALERT AT 5% OF INTERVAL REMAINING		N/C
N	80G-002	PTO MINIMUM RPM - 700		N/C
	80S-003	PTO 1, DASH SWITCH, ENGAGE BEFORE DRIVING		N/C
	80V-001	ENGINE MOUNT PTO, DASH SWTICH ENGAGES PTO MODE, STATIONARY OPERATION		N/C
Engine Equipment				
	99C-124	EPA 2010 GHG 2024/CARB 2024 ULTRALOW NOX CONFIGURATION		N/C
	13E-001	STANDARD OIL PAN		N/C
	105-015	OIL FILL AND DIPSTICK LOCATED FOR ENHANCED SERVICEABILITY		\$83.00
	014-111	SIDE OF HOOD AIR INTAKE WITH ENGINE MOUNTED AIR CLEANER, WITH INSIDE/OUTSIDE AIR AND SNOW DOOR		\$759.00

Prepared by:
Troy Merwin
ATG MANCHESTER LLC
220 FRONTAGE RD.
MANCHESTER, NH 03103
Phone: (603) 668-1700

Data Code	Description	Weight Front	Weight Rear	Retail Price
124-1D7	DR 12V 160 AMP 28-SI QUADRAMOUNT PAD ALTERNATOR WITH REMOTE BATTERY VOLT SENSE	-10		N/C
292-222	(3) DTNA GENUINE, HIGH TEMP AGM STARTING AND CYCLING, MIN 2775CCA, 570RC, THREADED STUD BATTERIES			STD
290-1AC	PASSENGER SEAT BATTERY BOX VENTED TO OUTSIDE OF CAB			STD
282-013	BATTERY BOX MOUNTED UNDER PASSENGER SEAT			STD
291-017	WIRE GROUND RETURN FOR BATTERY CABLES WITH ADDITIONAL FRAME GROUND RETURN			STD
289-006	PLASTIC BATTERY BOX COVER			STD
293-058	POSITIVE LOAD DISCONNECT WITH CAB MOUNTED CONTROL SWITCH MOUNTED OUTBOARD DRIVER SEAT	2		\$261.00
295-029	POSITIVE AND NEGATIVE POSTS FOR JUMPSTART LOCATED ON FRAME NEXT TO STARTER	2		\$118.00
107-045	CUMMINS NATURALLY ASPIRATED 18.7 CFM AIR COMPRESSOR WITH INTERNAL SAFETY VALVE			N/C
152-041	ELECTRONIC ENGINE INTEGRAL SHUTDOWN PROTECTION SYSTEM			STD
128-004	CUMMINS INTEBRAKE BRAKE WITH HIGH MED LOW BRAKE			N/C
016-1C2	RH OUTBOARD UNDER STEP MOUNTED HORIZONTAL AFTERTREATMENT SYSTEM ASSEMBLY WITH RH B-PILLAR MOUNTED VERTICAL TAILPIPE			STD
28F-015	ENGINE AFTERTREATMENT DEVICE, AUTOMATIC OVER THE ROAD ACTIVE REGENERATION AND VIRTUAL REGENERATION REQUEST SWITCH IN CLUSTER AND DASH MOUNTED INHIBIT SWITCH			STD
239-032	11 FOOT 00 INCH (132 INCH+0/-5.9 INCH) EXHAUST SYSTEM HEIGHT			N/C
233-019	STANDARD CURVE BRIGHT UPPER STACK(S) AND ELBOW(S)			\$145.00
237-1CR	RH CURVED VERTICAL TAILPIPE B-PILLAR MOUNTED ROUTED FROM STEP			STD
23U-002	13 GALLON DIESEL EXHAUST FLUID TANK	9	3	(\$187.00)
23Z-005	UNPOLISHED ALUMINUM WST DIESEL EXHAUST FLUID TANK COVER			STD
43X-001	LH HEAVY DUTY STANDARD DIESEL EXHAUST FLUID TANK LOCATION			STD
43Y-001	STANDARD DIESEL EXHAUST FLUID TANK CAP			STD

Data Code	Description	Weight Front	Weight Rear	Retail Price
242-001	STAINLESS STEEL AFTERTREATMENT DEVICE/MUFFLER/TAILPIPE SHIELD			STD
273-059	ELECTRONICALLY CONTROLLED VARIABLE SPEED VISCOUS FAN DRIVE			\$246.00
276-002	AUTOMATIC FAN CONTROL WITH DASH SWITCH AND INDICATOR LIGHT, NON ENGINE MOUNTED			\$10.00
122-130	DAVCO 385 FUEL/WATER SEPARATOR WITH ESOC AND 12 VOLT PREHEATER AND WATER IN FUEL SENSOR	10		\$464.00
110-003	CUMMINS SPIN ON FUEL FILTER			N/C
118-001	FULL FLOW OIL FILTER			STD
266-109	1400 SQUARE INCH VOCATIONAL RADIATOR WITH PROTECTION PACKAGE	20		\$337.00
103-039	ANTIFREEZE TO -34F, OAT (NITRITE AND SILICATE FREE) EXTENDED LIFE COOLANT			STD
171-007	GATES BLUE STRIPE COOLANT HOSES OR EQUIVALENT			STD
261-001	STANDARD CHARGE AIR COOLER PLUMBING			STD
270-016	RADIATOR DRAIN VALVE			N/C
168-002	LOWER RADIATOR GUARD			STD
360-013	1350 ADAPTER FLANGE FOR FRONT PTO PROVISION	10		\$1,338.00
138-005	PHILLIPS-TEMRO 1500 WATT/115 VOLT BLOCK HEATER	4		\$30.00
166-005	PHILLIPS-TEMRO 300 WATT/115 VOLT OIL PREHEATER	4		\$46.00
140-022	CHROME ENGINE HEATER RECEPTACLE MOUNTED UNDER LH DOOR			\$80.00
155-055	DELCO 12V 39MT HD/OCP STARTER WITH THERMAL PROTECTION AND INTEGRATED MAGNETIC SWITCH			N/C

Transmission

342-1NC	ALLISON 4700 RDS AUTOMATIC TRANSMISSION WITH PTO PROVISION	390	150	\$19,301.00
---------	--	-----	-----	-------------

Transmission Equipment

343-339	ALLISON VOCATIONAL PACKAGE 223 - AVAILABLE ON 3000/4000 PRODUCT FAMILIES WITH VOCATIONAL MODELS RDS, HS, MH AND TRV			N/C
84B-012	ALLISON VOCATIONAL RATING FOR ON/OFF HIGHWAY APPLICATIONS AVAILABLE WITH ALL PRODUCT FAMILIES			N/C

Data Code	Description	Weight Front	Weight Rear	Retail Price
84C-039	PRIMARY MODE GEARS, LOWEST GEAR 1, START GEAR 2, HIGHEST GEAR 7, AVAILABLE FOR 4700/4800 PRODUCT FAMILIES ONLY			N/C
84D-039	SECONDARY MODE GEARS, LOWEST GEAR 1, START GEAR 2, HIGHEST GEAR 7, AVAILABLE FOR 4700 PRODUCT FAMILIES ONLY			N/C
84E-000	PRIMARY SHIFT SCHEDULE RECOMMENDED BY DTNA AND ALLISON, THIS DEFINED BY ENGINE AND VOCATIONAL USAGE			N/C
84F-000	SECONDARY SHIFT SCHEDULE RECOMMENDED BY DTNA AND ALLISON, THIS DEFINED BY ENGINE AND VOCATIONAL USAGE			N/C
84G-000	PRIMARY SHIFT SPEED RECOMMENDED BY DTNA AND ALLISON, THIS DEFINED BY ENGINE AND VOCATIONAL USAGE			N/C
84H-000	SECONDARY SHIFT SPEED RECOMMENDED BY DTNA AND ALLISON, THIS DEFINED BY ENGINE AND VOCATIONAL USAGE			N/C
84N-200	FUEL SENSE 2.0 DISABLED - PERFORMANCE - TABLE BASED			N/C
84V-001	DIRECTION CHANGE ENABLED WITH MULTIPLEXED SERVICE BRAKES - ALLISON 5TH GEN TRANSMISSIONS			N/C
85J-002	2ND REVERSE, WIRED/SELECTOR			N/C
353-073	QUICKFIT BODY LIGHTING CONNECTOR UNDER CAB, WITH CAP			\$125.00
34C-011	ELECTRONIC TRANSMISSION WIRING TO CUSTOMER INTERFACE CONNECTOR			\$84.00
362-823	CUSTOMER INSTALLED CHELSEA 280 SERIES PTO			N/C
363-001	PTO MOUNTING, LH SIDE OF MAIN TRANSMISSION ALLISON			N/C
341-018	MAGNETIC PLUGS, ENGINE DRAIN, TRANSMISSION DRAIN, AXLE(S) FILL AND DRAIN			STD
345-078	HEAVY DUTY ELECTRONIC TRANSMISSION SHIFT CONTROL, COLUMN MOUNTED			STD
370-006	WATER TO OIL TRANSMISSION COOLER	15		N/C
346-003	TRANSMISSION OIL CHECK AND FILL WITH ELECTRONIC OIL LEVEL CHECK			N/C
35T-001	SYNTHETIC TRANSMISSION FLUID (TES-295 COMPLIANT)			N/C

Front Axle and Equipment

400-1AC	MFS-20-133A 20,000# FL1 71.0 INCH KPI/3.74 INCH DROP SINGLE FRONT AXLE	240		\$945.00
---------	--	-----	--	----------

Data Code	Description	Weight Front	Weight Rear	Retail Price
418-058	CONMET PRESET PLUS PREMIUM ALUMINUM FRONT HUBS			(\$620.00)
402-030	MERITOR 16.5X6 Q+ CAST SPIDER CAM FRONT BRAKES, DOUBLE ANCHOR, FABRICATED SHOES	10		(\$278.00)
403-002	NON-ASBESTOS FRONT BRAKE LINING			STD
419-014	MERITOR STEELLITE X30 FRONT BRAKE DRUMS	-30		\$514.00
427-001	FRONT BRAKE DUST SHIELDS			(\$3.00)
409-006	FRONT OIL SEALS			STD
408-001	VENTED FRONT HUB CAPS WITH WINDOW, CENTER AND SIDE PLUGS - OIL			STD
405-008	GUNITE AUTOMATIC FRONT SLACK ADJUSTERS			\$142.00
536-104	DUAL POWER STEERING GEARS, BENDIX 16-20K	80		\$1,542.00
534-003	4 QUART POWER STEERING RESERVOIR			N/C
533-001	OIL/AIR POWER STEERING COOLER			N/C
40T-002	CURRENT AVAILABLE SYNTHETIC 75W-90 FRONT AXLE LUBE			STD

Front Suspension

620-006	20,000# FLAT LEAF FRONT SUSPENSION	250		\$425.00
619-002	THREADED SPRING PINS AND BUSHINGS - FRONT SUSPENSION			N/C
62G-015	AUXILIARY AIR SPRING ON RIGHT SIDE FOR PLOW APPLICATIONS	25		\$945.00
410-998	NO FRONT SHOCK ABSORBERS	-30		N/C

Rear Axle and Equipment

420-103	RT-46-160 46,000# R-SERIES TANDEM REAR AXLE		420	\$3,061.00
450-060	CONMET PRESET PLUS PREMIUM IRON REAR HUBS		60	(\$1,448.00)
421-538	5.38 REAR AXLE RATIO			N/C
424-001	IRON REAR AXLE CARRIER WITH STANDARD AXLE HOUSING			STD
386-089	SPL250 HT XL DANA SPICER MAIN DRIVELINE			\$382.00
388-012	SPL170 XL DANA SPICER INTERAXLE DRIVELINE WITH HALF ROUND YOKES		10	\$388.00
452-006	DRIVER CONTROLLED TRACTION DIFFERENTIAL - BOTH TANDEM REAR AXLES		30	\$1,317.00

Data Code	Description	Weight Front	Weight Rear	Retail Price
878-022	(1) INTERAXLE LOCK VALVE, (1) DRIVER CONTROLLED DIFFERENTIAL LOCK FORWARD-REAR AXLE VALVE AND (1) REAR-REAR AXLE VALVE			\$46.00
87A-005	INDICATOR LIGHT FOR EACH INTERAXLE LOCKOUT SWITCH			N/C
87B-009	INDICATOR LIGHT AND BUZZER FOR EACH DIFFERENTIAL LOCKOUT SWITCH			N/C
423-020	MERITOR 16.5X7 Q+ CAST SPIDER CAM REAR BRAKES, DOUBLE ANCHOR, FABRICATED SHOES			(\$937.00)
433-002	NON-ASBESTOS REAR BRAKE LINING			STD
434-003	STANDARD BRAKE CHAMBER LOCATION			STD
451-023	CONMET CAST IRON REAR BRAKE DRUMS			\$646.00
425-002	REAR BRAKE DUST SHIELDS		5	(\$25.00)
440-006	REAR OIL SEALS			STD
426-112	WABCO TRISTOP-D LONGSTROKE 30/36 2-DRIVE AXLE SPRING PARKING CHAMBERS			(\$35.00)
428-003	HALDEX AUTOMATIC REAR SLACK ADJUSTERS			\$344.00
41T-002	CURRENT AVAILABLE SYNTHETIC 75W-90 REAR AXLE LUBE			N/C
42T-001	STANDARD REAR AXLE BREATHER(S)			STD
Rear Suspension				
622-248	CHALMERS 854 46,000# HIGH STABILITY REAR SUSPENSION WITH #29 CAN		420	\$5,016.00
621-116	11.5 INCH NOMINAL RIDE HEIGHT (510MM GLOBAL REFERENCE HEIGHT)			N/C
624-009	54 INCH AXLE SPACING			N/C
623-006	FORE/AFT AND TRANSVERSE CONTROL RODS			N/C
439-998	NO REAR SHOCK ABSORBERS		-80	N/C
Pusher / Tag Equipment				
429-998	NO PUSHER/TAG BRAKE DUST SHIELDS			STD
Brake System				
490-1AV	WABCO 6S/6M ABS WITH TRACTION CONTROL WITH ATC SHUT OFF SWITCH			(\$73.00)
871-001	REINFORCED NYLON, FABRIC BRAID AND WIRE BRAID CHASSIS AIR LINES			STD
432-003	RELAY VALVE WITH 5-8 PSI CRACK PRESSURE, NO REAR PROPORTIONING VALVE			STD
480-086	BW AD-9SI BRAKE LINE AIR DRYER WITH HEATER			\$83.00
479-015	AIR DRYER FRAME MOUNTED			N/C

Data Code	Description	Weight Front	Weight Rear	Retail Price
460-001	STEEL AIR BRAKE RESERVOIRS			STD
477-004	PULL CABLES ON ALL AIR RESERVOIR(S)			STD

Trailer Connections

914-025	AIR CONNECTIONS TO END OF FRAME WITH GLAD HANDS FOR TRUCK AND DUST COVERS			\$95.00
919-063	(1) QUICKFIT PROGRAMMABLE SOLENOID W/STATE RETENTION PLUMBED TO BACK OF CAB			\$83.00
296-010	PRIMARY CONNECTOR/RECEPTACLE WIRED FOR SEPARATE STOP/TURN, ABS CENTER PIN POWERED THROUGH IGNITION			\$40.00
303-025	SAE J560 7-WAY PRIMARY TRAILER CABLE RECEPTACLE MOUNTED END OF FRAME			\$130.00

Wheelbase & Frame

545-124	5590MM (220 INCH) WHEELBASE, SFA ONLY			N/C
546-106	13.0MM X 87.0MM X 311.0MM STEEL FRAME (0.51X3.43X12.24 INCH) 120 KSI	370	330	\$1,841.00
552-018	1625MM (64 INCH) REAR FRAME OVERHANG			N/C
55W-006	FRAME OVERHANG RANGE: 61 INCH TO 70 INCH	-30	90	N/C
549-002	24 INCH INTEGRAL FRONT FRAME EXTENSION	120		\$187.00
AC8-99D	CALC'D BACK OF CAB TO REAR SUSP C/L (CA) : 128.74 in			
AE4-99D	CALC'D FRAME LENGTH - OVERALL : 336.68 in			
ZF1-99D	FRAME HEIGHT TOP FRONT UNLADEN : 45.74 in			
ZF2-99D	FRAME HEIGHT TOP FRONT LADEN : 42.28 in			
ZF3-99D	FRAME HEIGHT TOP REAR UNLADEN : 44.35 in			
ZF4-99D	FRAME HEIGHT TOP REAR LADEN : 43.05 in			
553-001	SQUARE END OF FRAME			STD
559-001	STANDARD WEIGHT ENGINE CROSSMEMBER			STD
561-007	HEAVY DUTY BACK OF TRANSMISSION CROSSMEMBER	10		\$315.00
562-063	STANDARD CAST ALUMINUM MIDSHIP			STD
572-082	STANDARD CAST ALUMINUM REAR MOST CROSSMEMBER			STD
565-001	STANDARD SUSPENSION CROSSMEMBER		20	N/C
568-012	CAST ALUMINUM REAR SUSPENSION CROSSMEMBER			STD

Chassis Equipment

025-001	UNPOLISHED ALUMINUM WST EQUIPMENT COVERS			STD
---------	--	--	--	-----

Data Code	Description	Weight Front	Weight Rear	Retail Price
556-127	BRIGHT STEEL 1/8 INCH VOCATIONAL BUMPER			STD
558-998	NO FRONT TOW HOOKS	-15		(\$64.00)
574-001	BUMPER MOUNTING FOR SINGLE LICENSE PLATE			STD
551-034	CLASS 10.9 THREADED METRIC FASTENERS			STD
44Z-002	EXTERIOR HARNESSES WRAPPED IN ABRASION TAPE			STD
924-007	LEFT HAND SIDE HEAVY DUTY BRACKETS REQUIRED			\$21.00
928-007	RIGHT HAND SIDE HEAVY DUTY BRACKETS REQUIRED			\$21.00
Fuel Tanks				
204-154	80 GALLON/302 LITER ALUMINUM FUEL TANK - LH	-10		\$86.00
218-006	25 INCH DIAMETER FUEL TANK(S)			STD
215-006	POLISHING OF FUEL/HYDRAULIC TANK(S) WITH POLISHED STAINLESS STEEL BANDS			\$351.00
212-007	FUEL TANK(S) FORWARD			STD
664-001	PLAIN STEP FINISH			STD
205-002	CHROME FUEL TANK CAP(S)			\$13.00
216-020	EQUIFLO INBOARD FUEL SYSTEM			STD
202-016	HIGH TEMPERATURE REINFORCED NYLON FUEL LINE			STD
213-001	INSULATION FOR FUEL LINES	2		\$60.00
Tires				
093-2CC	MICHELIN XZU-S2 315/80R22.5 20 PLY RADIAL FRONT TIRES	100		\$736.00
094-13T	MICHELIN X WORKS D 11R22.5 16 PLY RADIAL REAR TIRES		248	\$512.00
Wheels				
502-664	ALCOA ULTRA ONE 89U63X 22.5X9.00 10-HUB PILOT 3.12 INSET 10-HD ALUMINUM FRONT WHEELS	-44		\$170.00
505-736	ACCURIDE 43644 ACCU-LITE 22.5X8.25 10-HUB PILOT ALUMINUM DISC REAR WHEELS		-256	N/C
496-011	FRONT WHEEL MOUNTING NUTS			STD
497-011	REAR WHEEL MOUNTING NUTS			STD
Cab Exterior				
829-116	121 INCH BBC ALUMINUM CONVENTIONAL CAB			STD
82A-028	STAINLESS STEEL CAB ACCENT MOLDING			STD
667-001	FRONT FENDERS			STD

Data Code	Description	Weight Front	Weight Rear	Retail Price
754-017	BOLT-ON MOLDED FLEXIBLE FENDER EXTENSIONS	10		\$115.00
678-066	INTERIOR GRAB HANDLES WITH ADDED LOWER LH AND RH A PILLAR GRAB HANDLES AND LH AND RH EXTERIOR NON-SLIP GRAB HANDLES			STD
65X-010	BRIGHT HOOD MOUNTED AIR INTAKE GRILLE, BLACK SCREEN, WITH LED ACCENT LIGHTS			STD
640-016	X-SERIES STEEL REINFORCED ALUMINUM CAB			STD
644-049	X-SERIES VOCATIONAL HOOD WITH ACCESS HATCH	10		\$384.00
67U-001	HOOD OPENING ASSIST WITH LOCKING STRUT			STD
652-016	WESTERN STAR NAMEPLATES			STD
727-012	DUAL HADLEY SD-978 26 INCH RECTANGULAR AIR HORNS			STD
726-001	SINGLE ELECTRIC HORN			STD
575-001	REAR LICENSE PLATE MOUNT END OF FRAME			STD
327-006	SWITCH, INDICATOR LIGHT AND WIRING FOR (1) CUSTOMER FURNISHED BEACON			\$61.00
312-095	DUAL STAGE INTELLIGENT LED HEADLIGHTS WITH HEATED LENS SYSTEM			STD
302-073	VISOR MOUNTED LED MARKER LIGHTS			N/C
314-824	WIRING AND SWITCH FOR CUSTOMER FURNISHED SNOW PLOW LAMPS WITH DUAL CONNECTIONS AT BUMPER			\$162.00
311-001	DAYTIME RUNNING LIGHTS			STD
294-1AY	INTEGRAL LED STOP/TAIL/BACKUP LIGHTS			STD
300-043	LED SIDE TURN SIGNAL			STD
318-1D7	(2) FLUSH LED UTILITY LIGHTS MOUNTED BACK OF CAB/SLEEPER	6		\$172.00
744-106	C-BAR MIRROR SYSTEM WITH DUAL HEATED MIRRORS WITH INTEGRAL HEATED CONVEX, DUAL REMOTE, STAINLESS STEEL BACK COVER, AND BLACK C-BAR			STD
796-001	102 INCH EQUIPMENT WIDTH			STD
743-209	LH AND RH CONVEX MIRRORS INTEGRAL WITH PRIMARY MIRRORS			STD
74A-001	RH DOWN VIEW MIRROR			STD
729-001	STANDARD SIDE/REAR REFLECTORS			STD
677-098	UNPOLISHED ALUMINUM WST AFTERTREATMENT SYSTEM COVER			STD
764-020	STAINLESS STEEL EXTERIOR SUN VISOR WITH INTEGRAL MARKER LIGHTS	16		\$538.00

Prepared by:
 Troy Merwin
 ATG MANCHESTER LLC
 220 FRONTAGE RD.
 MANCHESTER, NH 03103
 Phone: (603) 668-1700

Data Code	Description	Weight Front	Weight Rear	Retail Price
768-064	SINGLE SOLAR TINTED REAR WINDOW, (1) 31 INCH X 20 INCH			STD
663-019	1-PIECE ROPED-IN SOLAR GREEN GLASS WINDSHIELD			STD
659-006	8 LITER (2 GAL) WINDSHIELD WASHER RESERVOIR, CAB MOUNTED, WITH FLUID LEVEL INDICATOR			STD
Cab Interior				
055-015	X-SERIES BASE INTERIOR TRIM LEVEL PACKAGE			STD
707-1C3	CHARCOAL BLACK VINYL BASE LEVEL INTERIOR			STD
70K-016	CARBON WITH BASE BLACK ACCENT			STD
772-035	BLACK MATS WITH ADDED FLOOR HEAT AND NOISE INSULATION			\$126.00
785-014	(2) DASH MOUNTED POWER OUTLETS AND COIN TRAY			STD
691-001	FORWARD ROOF MOUNTED CONSOLE			STD
693-019	LH AND RH DOOR STORAGE POCKETS INTEGRATED INTO MOLDED DOOR PANELS			STD
741-015	(2) COAT HOOKS ON BACKWALL OF CAB			STD
738-021	DIGITAL ALARM CLOCK IN DRIVER DISPLAY			STD
720-072	2-1/2 LB. FIRE EXTINGUISHER SHIPPED LOOSE IN CAB	5		\$40.00
170-045	STANDARD HEATER PLUMBING WITH BALL SHUTOFF VALVES AT SUPPLY LINES ONLY			\$19.00
698-001	RADIATOR MOUNTED AIR CONDITIONER CONDENSER			STD
739-034	PREMIUM INSULATION			\$83.00
324-1B3	STANDARD LED CAB LIGHTING			STD
787-998	NO SECURITY DEVICE			(\$15.00)
657-001	DOOR LOCKS AND IGNITION SWITCH KEYED THE SAME			STD
78G-004	KEY QUANTITY OF 4			\$18.00
655-028	LH AND RH ELECTRIC DOOR LOCKS WITH AUTO UNLOCK FEATURE WHEN DOOR IS SET FROM OPEN TO CLOSED POSITION			STD
64C-003	BLACK DOOR HANDLES			STD
756-1J6	PREMIUM 2.0 HIGH BACK AIR SUSPENSION DRIVER SEAT WITH 2 AIR LUMBAR, INTEGRATED CUSHION EXTENSION, TILT AND ADJUSTABLE SHOCK	20		\$23.00
760-294	BATTERY BOX MID BACK NON SUSPENSION PASSENGER SEAT			STD

Data Code	Description	Weight Front	Weight Rear	Retail Price
757-001	BLACK SUSPENSION COVER FOR AIR DRIVER SEAT	2		\$50.00
759-007	DUAL DRIVER SEAT ARMRESTS, NO PASSENGER SEAT ARMRESTS			STD
758-135	BLACK MORDURA CLOTH DRIVER SEAT COVER WITH EMBROIDERED LOGO			STD
761-138	BLACK MORDURA CLOTH PASSENGER SEAT COVER WITH NO LOGO			STD
763-1AA	3 POINT ADJUSTABLE D-RING RETRACTOR DRIVER AND FIXED D-RING RETRACTOR PASSENGER SEAT BELTS			STD
532-002	ADJUSTABLE TILT AND TELESCOPING STEERING COLUMN			STD
540-044	4-SPOKE 18 INCH (450MM) BLACK STEERING WHEEL WITH SWITCHES			STD
765-021	DRIVER AND PASSENGER INTERIOR SUN VISORS WITH ILLUMINATED VANITY MIRRORS			\$27.00

Instruments & Controls

185-004	STANDARD FOOT PEDAL SYSTEM			STD
106-002	ELECTRONIC ACCELERATOR CONTROL			(\$51.00)
870-001	BLACK GAUGE BEZELS			STD
734-018	STANDARD CENTER INSTRUMENT PANEL			STD
838-010	((1) PNEUMATIC TRACTOR AND (1) TRAILER BRAKE APPLICATION AIR GAUGE			\$136.00
840-001	DUAL NEEDLE PRIMARY AND SECONDARY AIR PRESSURE GAUGE			STD
198-025	INTAKE MOUNTED AIR RESTRICTION INDICATOR WITHOUT GRADUATIONS			STD
721-001	97 DB BACKUP ALARM		3	\$34.00
149-015	ELECTRONIC CRUISE CONTROL WITH CONTROLS ON STEERING WHEEL SPOKES			STD
156-007	KEY OPERATED IGNITION SWITCH AND INTEGRAL START POSITION; 4 POSITION OFF/RUN/START/ACCESSORY			STD
811-044	PREMIUM INSTRUMENT CLUSTER WITH 5.0 INCH TFT COLOR DISPLAY			STD
81B-003	DIGITAL PANEL LAMP DIMMER SWITCH IN DRIVER DISPLAY			STD
160-045	HEAVY DUTY ONBOARD DIAGNOSTICS INTERFACE CONNECTOR WITH DUST CAP LOCATED BELOW LH DASH			STD
844-001	2 INCH ELECTRIC FUEL GAUGE			STD
148-072	ENGINE REMOTE INTERFACE WITH ONE OR MORE SET SPEEDS			\$134.00

Data Code	Description	Weight Front	Weight Rear	Retail Price
856-001	ELECTRICAL ENGINE COOLANT TEMPERATURE GAUGE			STD
854-008	DIGITAL ENGINE OIL TEMPERATURE IN DRIVER DISPLAY			(\$36.00)
852-002	ELECTRIC ENGINE OIL PRESSURE GAUGE			STD
864-022	DIGITAL TRANSMISSION OIL TEMPERATURE IN DRIVER DISPLAY			(\$47.00)
867-004	ELECTRONIC OUTSIDE TEMPERATURE SENSOR DISPLAY IN DRIVER MESSAGE CENTER			STD
830-017	ENGINE AND TRIP HOUR METERS INTEGRAL WITHIN DRIVER DISPLAY			STD
372-123	PTO CONTROLS FOR ENHANCED VEHICLE ELECTRIC/ELECTRONIC ARCHITECTURE			STD
736-998	NO OBSTACLE DETECTION SYSTEM			(\$4,324.00)
73K-998	NO SIDE OBJECT DETECTION SYSTEM			STD
72J-998	NO DR ASSIST SYSTEM			(\$32.00)
49B-004	ELECTRONIC STABILITY CONTROL			STD
73B-998	NO LANE DEPARTURE WARNING SYSTEM			(\$1,080.00)
35M-010	QUICKFIT PROGRAMMABLE INTERFACE MODULE	10		\$154.00
6TS-008	(2) TMC RP1226 ACCESSORY CONNECTORS: (1) LOCATED BEHIND PASSENGER SIDE REMOVABLE DASH PANEL (1) CENTER OF OVERHEAD CONSOLE			\$30.00
746-135	AM/FM/WB WORLD TUNER RADIO WITH SIRIUSXM, BLUETOOTH, IPOD INTERFACE, USB AND AUXILIARY INPUTS, J1939			N/C
747-001	DASH MOUNTED RADIO			STD
750-041	STANDARD SPEAKER SYSTEM			STD
753-998	NO AM/FM RADIO ANTENNA			(\$11.00)
748-045	UNIDEN BEARCAT 880 FACTORY INSTALLED CB RADIO WITH 10 CHANNEL WEATHERBAND	5		\$214.00
749-001	ROOF/OVERHEAD CONSOLE CB RADIO PROVISION			STD
751-001	SINGLE REMOTE SPEAKER WITH LEAD FOR 2-WAY RADIO			STD
752-004	SINGLE FIBERGLASS LH MIRROR MOUNTED CB ANTENNA WITH BRACKET AND LEAD			STD
75W-001	HEADLINER MULTI-BAND ANTENNA: AM/FM/WEATHERBAND, WIFI/BLUETOOTH, GNSS/GPS			\$75.00
78C-003	INTEROPERABLE SDAR ANTENNA			\$91.00

Prepared by:
Troy Merwin
ATG MANCHESTER LLC
220 FRONTAGE RD.
MANCHESTER, NH 03103
Phone: (603) 668-1700

Data Code	Description	Weight Front	Weight Rear	Retail Price
810-027	ELECTRONIC MPH SPEEDOMETER WITH SECONDARY KPH SCALE, WITHOUT ODOMETER			STD
812-032	ELECTRONIC 2500 RPM TACHOMETER			STD
813-1C8	DETROIT CONNECT PLATFORM HARDWARE			STD
8D1-305	5 YEARS DAIMLER CONNECTIVITY BASE PACKAGE (FEATURES VARY BY MODEL) POWERED BY DETROIT CONNECT			N/C
162-002	IGNITION SWITCH CONTROLLED ENGINE STOP			STD
329-117	FOUR EXTRA HARDWIRED SWITCHES IN DASH, ROUTE TO BETWEEN SEATS, CAPPED			\$150.00
4C1-025	HARDWIRE SWITCH #1, ON/OFF LATCHING, 20 AMPS IGNITION POWER			\$15.00
4C2-026	HARDWIRE SWITCH #2, ON/OFF LATCHING, 10 AMPS BATTERY POWER			N/C
4C3-017	HARDWIRE SWITCH #3, ON/OFF LATCHING, 10 AMPS BATTERY POWER			N/C
4C4-016	HARDWIRE SWITCH #4, ON/OFF LATCHING, 20 AMPS IGNITION POWER			\$15.00
81Y-005	PRE-TRIP INSPECTION FEATURE FOR EXTERIOR LAMPS ONLY			STD
482-001	BW TRACTOR PROTECTION VALVE			\$120.00
883-001	TRAILER HAND CONTROL BRAKE VALVE			\$35.00
842-006	DIGITAL TURBO AIR PRESSURE IN DRIVER DISPLAY			(\$23.00)
836-015	DIGITAL VOLTAGE DISPLAY INTEGRAL WITH DRIVER DISPLAY			STD
304-030	ROTARY HEADLAMP SWITCH, MARKER LIGHTS/HEADLIGHTS SWITCH WITH PULL OUT FOR OPTIONAL FOG/ROAD LAMPS			N/C
882-021	TWO VALVE PARKING BRAKE SYSTEM WITH DASH VALVE CONTROL AUTONEUTRAL AND WARNING INDICATOR			\$15.00
299-020	SELF CANCELING TURN SIGNAL SWITCH WITH DIMMER, HEADLAMP FLASH, WASH/WIPE/INTERMITTENT			STD
4E1-013	PROGRAMMABLE SWITCHES/INDICATORS LOCATED IN AUXILIARY PANEL			N/C
48H-003	QUICKFIT POWERTRAIN INTERFACE CONNECTOR UNDER CAB WITH CAPS			\$79.00
4CG-004	4 EXTRA PROGRAMMABLE SWITCHES/INDICATORS			\$52.00
	\$A1A0136ZZ,A1B0136ZZ,A1C0136ZZ,A1D0136ZZ			
48C-003	QUICKFIT PROGRAMMABLE INTERFACE CONNECTOR(S) UNDER CAB WITH CAP			\$6.00

Prepared by:
 Troy Merwin
 ATG MANCHESTER LLC
 220 FRONTAGE RD.
 MANCHESTER, NH 03103
 Phone: (603) 668-1700

Data Code	Description	Weight Front	Weight Rear	Retail Price
Design				
065-000	PAINT: ONE SOLID COLOR			\$1,043.00
Color				
980-7KF	CAB COLOR A: G8125EY SOVEREIGN BLUE MET ELITE EY			N/C
986-020	BLACK, HIGH SOLIDS POLYURETHANE CHASSIS PAINT			STD
Certification / Compliance				
996-001	U.S. FMVSS CERTIFICATION, EXCEPT SALES CABS AND GLIDER KITS			STD
Sales Programs				
PMY-3X2	STARQUOTE 47X/49X SALES PROGRAM			N/C

TOTAL VEHICLE SUMMARY

Adjusted List Price

Adjusted List Price ** \$258,120.00

Weight Summary

	Weight Front	Weight Rear	Total Weight
Factory Weight ⁺	10323 lbs	8623 lbs	18946 lbs
Total Weight ⁺	10323 lbs	8623 lbs	18946 lbs

ITEMS NOT INCLUDED IN ADJUSTED LIST PRICE

Other Factory Charges

PNZ-004	CARB-COMPLIANT BASE WARRANTY DD15 / X15E	\$1,915.00
PMV-024	GHG24 SURCHARGE - CUMMINS	\$1,686.00
RAU-025	MY25 ESCALATOR	\$2,750.00

Prepared by:
Troy Merwin
ATG MANCHESTER LLC
220 FRONTAGE RD.
MANCHESTER, NH 03103
Phone: (603) 668-1700

RAG-020	CUMMINS TARIFF CHARGE - \$205	\$205.00
RD1-305	5 YRS DAIMLER CONNECTIVITY BASE PKG (VARY BY MODEL) POWERED BY DETROIT CONNECT	N/C
RFY-022	FRONT TIRE SURCHARGE	\$130.00
RFU-022	REAR TIRE SURCHARGE	\$520.00
P73-2WS	STANDARD DESTINATION CHARGE	\$3,375.00

(+) Weights shown are estimates only.

If weight is critical, contact Customer Application Engineering.

(**) Prices shown do not include taxes, fees, etc... "Net Equipment Selling Price" is located on the Quotation Details Proposal Report.

(***) All cost increases for major components (Engines, Transmissions, Axles, Front and Rear Tires) and government mandated requirements, tariffs, and raw material surcharges will be passed through and added to factory invoices.

Prepared by:
 Troy Merwin
 ATG MANCHESTER LLC
 220 FRONTAGE RD.
 MANCHESTER, NH 03103
 Phone: (603) 668-1700

Q U O T A T I O N

WESTERN STAR 49X

SET FORWARD AXLE - TRUCK CUM X15 470V HP @ 1900 RPM, 2000 GOV RPM, 1750 LB-FT @ 900 RPM ALLISON 4700 RDS AUTOMATIC TRANSMISSION WITH PTO PROVISION RT-46-160 46,000# R-SERIES TANDEM REAR AXLE CHALMERS 854 46,000# HIGH STABILITY REAR SUSPENSION WITH #29 CAN	MFS-20-133A 20,000# FL1 71.0 INCH KPI/3.74 INCH DROP SINGLE FRONT AXLE 20,000# FLAT LEAF FRONT SUSPENSION 121 INCH BBC ALUMINUM CONVENTIONAL CAB 5590MM (220 INCH) WHEELBASE, SFA ONLY 13.0MM X 87.0MM X 311.0MM STEEL FRAME (0.51X3.43X12.24 INCH) 120 KSI 1625MM (64 INCH) REAR FRAME OVERHANG
---	---

			PER UNIT		TOTAL
VEHICLE PRICE	TOTAL # OF UNITS (1)	\$	172,636	\$	172,636
EXTENDED WARRANTY		\$	0	\$	0
DEALER INSTALLED OPTIONS		\$	0	\$	0
CUSTOMER PRICE BEFORE TAX		\$	172,636	\$	172,636

TAXES AND FEES

FEDERAL EXCISE TAX (FET)		\$	(358)	\$	(358)
TAXES AND FEES		\$	0	\$	0
OTHER CHARGES		\$	0	\$	0

TRADE-IN

TRADE-IN ALLOWANCE		\$	(0)	\$	(0)
---------------------------	--	----	-----	----	-----

BALANCE DUE	(LOCAL CURRENCY)	\$	172,278	\$	172,278
--------------------	-------------------------	-----------	----------------	-----------	----------------

COMMENTS:

Projected delivery on ___ / ___ / ___ provided the order is received before ___ / ___ / ___.

APPROVAL:

Please indicate your acceptance of this quotation by signing below:

Customer: X _____ Date: ___ / ___ / ___.

Daimler Truck Financial

Financing that works for you.

See your local dealer for a competitive quote from Daimler Truck Financial, or contact us at Information@dtfoffers.com.

Daimler Truck Financial offers a variety of finance, lease and insurance solutions to fit your business needs. For more information about our products and services, visit our website at www.daimler-truckfinancial.com.

D I M E N S I O N S

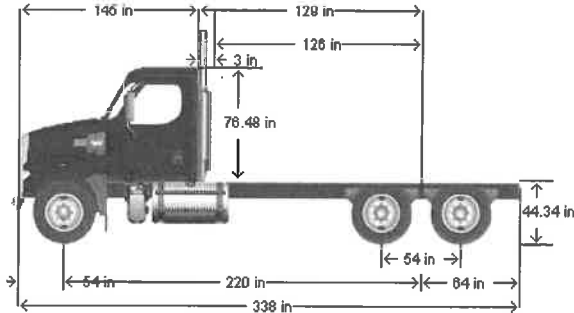

VEHICLE SPECIFICATIONS SUMMARY - DIMENSIONS

Model.....	49X
Wheelbase (545)	5590MM (220 INCH) WHEELBASE, SFA ONLY
Rear Frame Overhang (552).....	1625MM (64 INCH) REAR FRAME OVERHANG
Fifth Wheel (578)	NO FIFTH WHEEL
Mounting Location (577).....	NO FIFTH WHEEL LOCATION
Maximum Forward Position (in).....	0
Maximum Rearward Position (in)	0
Amount of Slide Travel (in).....	0
Slide Increment (in).....	0
Desired Slide Position (in).....	0.0
Cab Size (829).....	121 INCH BBC ALUMINUM CONVENTIONAL CAB
Sleeper (682).....	NO SLEEPER BOX/SLEEPERCAB
Exhaust System (016).....	RH OUTBOARD UNDER STEP MOUNTED HORIZONTAL AFTERTREATMENT SYSTEM ASSEMBLY WITH RH B-PILLAR MOUNTED VERTICAL TAILPIPE

TABLE SUMMARY - DIMENSIONS

Prepared by:
 Troy Merwin
 ATG MANCHESTER LLC
 220 FRONTAGE RD.
 MANCHESTER, NH 03103
 Phone: (603) 668-1700

Dimensions	Inches
Bumper to Back of Cab (BBC)	145.5
Bumper to Centerline of Front Axle (BA)	54.1
Front Axle to Back of Cab (AC)	91.3
Min. Cab to Body Clearance (CB)	3.0
Back of Cab to Centerline of Rear Axle(s) (CA)	128.7
Effective Back of Cab to Centerline of Rear Axle(s) (Effective CA)	125.7
Back of Cab Protrusions (Exhaust/Intake) (CP)	2.0
Back of Cab Protrusions (Side Extenders/Trim Tab) (CP)	0.0
Back of Cab Protrusions (CNG Tank)	0.0
Back of Cab Clearance (CL)	3.0
Back of Cab to End of Frame	192.7
Cab Height (CH)	76.5
Wheelbase (WB)	220.1
Frame Overhang (OH)	64.0
Overall Frame Length	336.7
Overall Length (OAL)	338.2
Rear Axle Spacing	54.0
Unladen Frame Height at Centerline of Rear Axle	44.3

Performance calculations are estimates only. If performance calculations are critical, please contact Customer Application Engineering.

SHIFT CHART

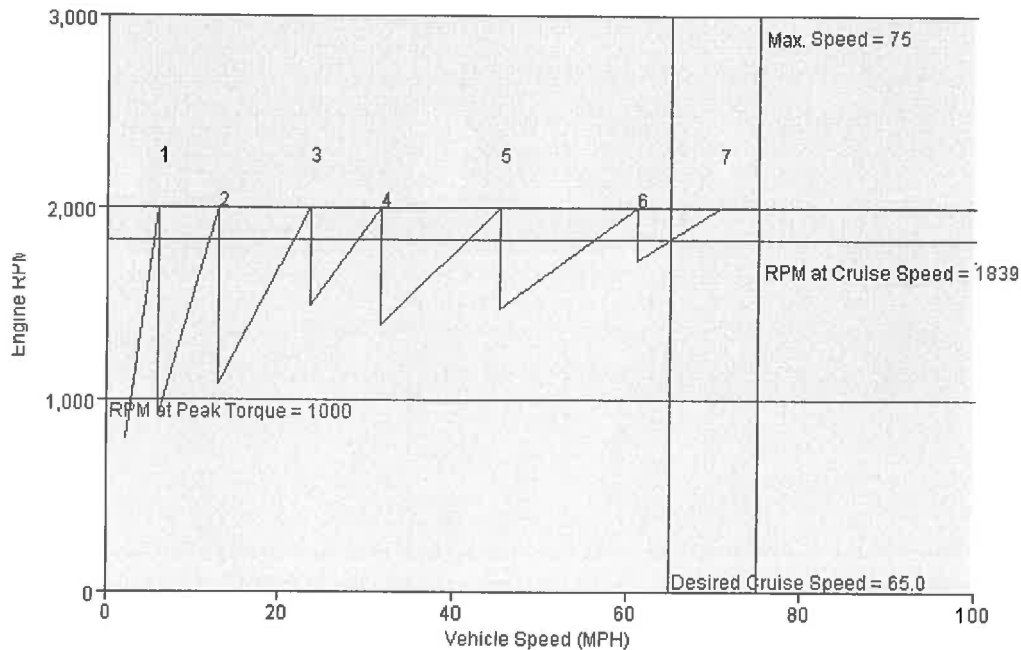

VEHICLE SPECIFICATIONS SUMMARY - SHIFT CHART

Model.....	49X
Cab Size (829).....	121 INCH BBC ALUMINUM CONVENTIONAL CAB
Desired Cruise Speed (mph).....	65.0
Engine (101).....	CUM X15 470V HP @ 1900 RPM, 2000 GOV RPM, 1750 LB-FT @ 900 RPM
RPM at Peak Torque.....	1000
Governed RPM.....	2000
Transmission (342).....	ALLISON 4700 RDS AUTOMATIC TRANSMISSION WITH PTO PROVISION
Gear Ratio: LL.....	N/A
Gear Ratio: L.....	N/A
Gear Ratio: 1.....	7.63
Gear Ratio: 2.....	3.51

Gear Ratio: 3	1.91
Gear Ratio: 4	1.43
Gear Ratio: 5	1
Gear Ratio: 6	0.74
Gear Ratio: 7	0.64
Gear Ratio: 8	N/A
Gear Ratio: 9	N/A
Gear Ratio: 10.....	N/A
Gear Ratio: 11.....	N/A
Gear Ratio: 12.....	N/A
Gear Ratio: 13.....	N/A
Gear Ratio: 14.....	N/A
Gear Ratio: 15.....	N/A
Gear Ratio: 16.....	N/A
Gear Ratio: 17.....	N/A
Gear Ratio: 18.....	N/A
Auxiliary Transmission (XMC 1) (352).....	NO AUXILIARY TRANSMISSION
Low Gear Ratio.....	N/A
High Gear Ratio.....	N/A
Transfer Case (373).....	NO TRANSFER CASE
Low Gear Ratio.....	N/A
High Gear Ratio.....	N/A
Rear Axle (420).....	RT-46-160 46,000# R-SERIES TANDEM REAR AXLE
Number of Speeds	1
Rear Axle Gear Ratio(s).....	5.38 REAR AXLE RATIO
Rear Tires (094).....	MICHELIN X WORKS D 11R22.5 16 PLY RADIAL REAR TIRES
Revolutions per Mile.....	493

TABLE SUMMARY - SHIFT CHART

Transmission Gear	Transmission Gear Ratio	Rear Axle Ratio	Overall Gear Ratio	Percent Split	RPM After Shift	MPH at Brake Torque	MPH at Governor
1	7.63	5.38	41.05	N/A	800	3.0	5.9
2	3.51	5.38	18.88	117.4	920	6.4	12.9
3	1.91	5.38	10.28	83.8	1088	11.8	23.7
4	1.43	5.38	7.69	33.6	1497	15.8	31.6
5	1.00	5.38	5.38	43.0	1399	22.6	45.2
6	0.74	5.38	3.98	35.1	1480	30.6	61.1
7	0.64	5.38	3.44	15.6	1730	35.3	70.7

Performance calculations are estimates only. If performance calculations are critical, please contact Customer Application Engineering.

G V W R

VEHICLE SPECIFICATIONS SUMMARY - GVWR

Model.....	49X
Cab Size (829).....	121 INCH BBC ALUMINUM CONVENTIONAL CAB
Expected Front Axle(s) Load (lbs).....	20000.0
Expected Pusher Axle(s) Load (lbs).....	0.0
Expected Rear Axle(s) Load (lbs).....	46000.0
Expected Tag Axle(s) Load (lbs).....	0.0
Expected GVW (lbs).....	66000
Expected GCW (lbs).....	80000.0
Front Axle (400).....	MFS-20-133A 20,000# FL1 71.0 INCH KPI/3.74 INCH DROP SINGLE FRONT AXLE
Front Suspension (620).....	20,000# FLAT LEAF FRONT SUSPENSION
Front Hubs (418).....	CONMET PRESET PLUS PREMIUM ALUMINUM FRONT HUBS
Front Disc Wheels (502).....	ALCOA ULTRA ONE 89U63X 22.5X9.00 10-HUB PILOT 3.12 INSET 10-HD ALUMINUM FRONT WHEELS
Front Tires (093).....	MICHELIN XZU-S2 315/80R22.5 20 PLY RADIAL FRONT TIRES
Front Brakes (402).....	MERITOR 16.5X6 Q+ CAST SPIDER CAM FRONT BRAKES, DOUBLE ANCHOR, FABRICATED SHOES
Steering Gear (536).....	DUAL POWER STEERING GEARS, BENDIX 16-20K
Rear Axle (420).....	RT-46-160 46,000# R-SERIES TANDEM REAR AXLE
Rear Suspension (622).....	CHALMERS 854 46,000# HIGH STABILITY REAR SUSPENSION WITH #29 CAN
Rear Hubs (450).....	CONMET PRESET PLUS PREMIUM IRON REAR HUBS
Rear Disc Wheels (505).....	ACCURIDE 43644 ACCU-LITE 22.5X8.25 10-HUB PILOT ALUMINUM DISC REAR WHEELS
Rear Tires (094).....	MICHELIN X WORKS D 11R22.5 16 PLY RADIAL REAR TIRES
Rear Brakes (423).....	MERITOR 16.5X7 Q+ CAST SPIDER CAM REAR BRAKES, DOUBLE ANCHOR, FABRICATED SHOES
Pusher / Tag Axle (443).....	NO PUSHER OR TAG AXLE
Pusher / Tag Suspension (626).....	NO PUSHER OR TAG SUSPENSION
Pusher / Tag Hubs (449).....	NO PUSHER OR TAG HUBS
Dead/Pusher/Tag Disc Wheels (509).....	NO PUSHER/TAG DISC WHEELS
Pusher / Tag Tires (095).....	NO PUSHER/TAG TIRES
Pusher / Tag Brakes (456).....	NO PUSHER/TAG BRAKES

TABLE SUMMARY - GVWR

Prepared by:
 Troy Merwin
 ATG MANCHESTER LLC
 220 FRONTAGE RD.
 MANCHESTER, NH 03103
 Phone: (603) 668-1700

	Front	Rear 1	Rear 2
Axle Component Weight Ratings			
Axles	20000	23000	23000
Suspension	20000	23000	23000
Hubs	20000	26000	26000
Brakes	20000	23000	23000
Wheels	20000	29600	29600
Tires	20000	24020	24020
Power Steering	20000	N/A	N/A
GAWR (per axle)	20000	23000	23000
GAWR (per axle system)	20000		46000
Expected Load (per axle system)	20000		46000
GVWR due to Frame	90000		
GVWR due to Transmission	300000		
Vehicle GVWR Summary			
Calculated GVWR	66000		
Expected GVWR	66000		
All weights displayed in pounds			

Performance calculations are estimates only. If performance calculations are critical, please contact Customer Application Engineering.

DUST SHIELDS, REAR BRAKE for Air Cam Brakes

DRAIN VALVE {Berg} with Pull Chains, for Air Tanks

AIR TANK LOCATION Mounted Between the Rails, Back of Cab, Right Side, for use with Between the Rails Air Tank System

BRAKES, FRONT {Bendix Spicer ES-165-6X} Air S-Cam Type, Heavy Duty Fabricated Spider, Fabricated Shoe, Single Anchor Pin, Size 16.5" X 6", 23,000-lb Capacity

BRAKES, REAR {Bendix Spicer ES-165-7X} Air S-Cam Type, Heavy Duty Fabricated Spider, Fabricated Shoe, Single Anchor Pin, Size 16.5" X 7", 23,000-lb Capacity per Axle

PARK BRAKE CHAMBERS, ADDITIONAL (2) Spring Brake Type

STEERING COLUMN Tilting and Telescoping

STEERING WHEEL 4-Spoke; 18" Dia., Black

STEERING GEAR (2) {Sheppard M100/HD94} Dual Power

DRIVELINE SYSTEM {Dana Spicer} SPL250 Main Driveline with SPL170 Interaxle Shaft, for 6x4

AFTERTREATMENT COVER Aluminum

EXHAUST SYSTEM Horizontal Aftertreatment System, Frame Mounted Right Side Under Cab, for Single Vertical Tail Pipe, Cab Mounted Right Side

ENGINE COMPRESSION BRAKE {Cummins} Interbrake for Cummins Signature/ISX/ X15 Engines; Furnished with Engine

TAIL PIPE (1) Turnback Type, Bright

EXHAUST HEIGHT 10'

MUFFLER/TAIL PIPE GUARD (1) Aluminum

SWITCH, FOR EXHAUST 3 Position, Momentary, Lighted Momentary, ON/CANCEL, Center Stable,

INHIBIT REGEN, mounted in IP Inhibits Diesel Particulate Filter Regeneration When Switch is Moved to ON While Engine is Running, Resets When Ignition is Turned OFF

ELECTRICAL SYSTEM 12-Volt, Standard Equipment Includes

HAZARD SWITCH Push On/Push Off, Located on Instrument Panel to Right of Steering Wheel

HEADLIGHT DIMMER SWITCH Integral with Turn Signal Lever

PARKING LIGHT Integral with Front Turn Signal and Rear Taillight

STARTER SWITCH Electric, Key Operated

STOP, TURN, TAIL & B/U LIGHTS Dual, Rear, Combination with Reflector

WINDSHIELD WIPER SWITCH 2-Speed with Wash and Intermittent Feature (5 Pre-Set Delays), Integral with Turn Signal Lever

WINDSHIELD WIPERS Single Motor, Electric, Cowl Mounted

HORN, ELECTRIC (2) Disc Style

FOG LIGHTS Prewire; Includes Auxiliary Switch and Wiring to Front Bumper, for Driving Lights or Fog Lights Mounted by Customer

HORN, AIR (2) Single Bell, Organ Tone, Extra Long, Chrome

JUMP START STUD (2) Remote Mounted

BEACON LIGHT WIRING for (2) Customer Installed Beacons, Includes 2-Way Switch

ALTERNATOR {Leece-Neville AVI160P2013} Brush Type, 12 Volt, 160 Amp Capacity,

BODY BUILDER WIRING INSIDE CAB; Includes Sealed Connectors for Tail/Amber, Turn/Marker/Backup/Accessory, Power/Ground, and Stop/Turn

BATTERY SYSTEM {Fleet rite} Maintenance-Free, (3) 12-Volt 2850CCA Total, Top Threaded Stud

SPEAKER, AUXILIARY, CB RADIO with Jack for CB; Mounted Left Side Above Driver's Door

2-WAY RADIO Wiring Effects; Wiring with 20 Amp Fuse Protection, Includes Ignition Wire with 5 Amp Fuse, Wire Ends Heat Shrink and Routed to Center of Header Console in Cab

SPEAKERS (2) 6.5" Dual Cone Mounted in Doors

CB RADIO Accommodation Package; Header Mounted; Feeds From Accessory Side of Ignition Switch; Includes Power Source and One (1) Antenna, Antenna Base with Wiring on Left Side Mirror

RADIO AM/FM/WB/Clock/Bluetooth/USB Input/Auxiliary Input

TRAILER CONNECTION SOCKET {Phillips} 7-Way, Mounted at Rear of Frame, Wired for Turn Signals Independent of Stop, Compatible with Trailers with Amber or Side Turn Lamps

AUXILIARY HARNESS 5.0' for Auxiliary Front Head Lights and Turn Signals for Front Plow Applications

BATTERY CABLES with 36" of Extra Length Coiled and Strapped Near Battery Box

BATTERY BOX Aluminum, with Plastic Cover, 18" Wide, 2-4 Battery Capacity, Mounted Right Side Back of Cab

TURN SIGNAL SWITCH Self-Canceling

ACCESSORY WIRING, SPECIAL Wiring for (2) Work Lights That Customer Will Install on Top Rear Corners of Cab, with Dash Switch; Will Also Activate Standard Work Light

HEADLIGHTS ON W/WIPERS Headlights Will Automatically Turn on if Windshield Wipers are turned on

HEADLIGHT WARNING BUZZER Sounds When Head Light Switch is on, and Ignition Switch is in "Off" Position

Auto Cancelling Direction switch

Six (6) additional rocker switches for lighting and electric clutch

ALARM, PARKING BRAKE Electric Horn Sounds in Repetitive Manner When Vehicle Park Brake is "NOT" Set, with Ignition "OFF" and any Door Opened

STARTING MOTOR {Mitsubishi Electric Automotive America 105P} 12-Volt, with Soft-Start HEADLIGHTS

AUTO Automatically Turn on with Low Ambient Light Levels, Feature can be Overridden.

JUNCTION BLOCK Stud, 100 Amp Battery Feed, protected by a Fusible Link, Stud to Be Used for Body Builder Feeds Inside Cab

CIRCUIT BREAKERS Manual-Reset (Main Panel) SAE Type III with Trip Indicators, Replaces All Fuses

HEADLIGHTS Halogen, Composite Combination

BATTERY WIRING MODIFICATION Battery Discharge Protection System: Control thru Body Controller

LIGHT, WORK LED, Pedestal Mounted, Back of Cab, with Switch on Instrument Panel BATTERY

DISCONNECT SWITCH 300 Amp, Disconnects Power to Power Distribution

Center (PDC), Does Not Disconnect Charging Circuits, Locks with Padlock, Cab Mounted

LOGOS EXTERIOR Model Badges

LOGOS EXTERIOR, ENGINE Badges

FRONT END Tilting, Composite

- Dual Access Hatches for Fluid Check and Fills with dip stick and fill extensions

GRILLE Chrome Vertical Accent Bars, with Black Mesh

PAINT SCHEMATIC, PT-1 Single Color, Design 100

PAINT TYPE Base Coat/Clear Coat, 1-2 Tone

PAINT CLASS Premium Color RED

PROMOTIONAL PACKAGE Government Silver Package

GCWR RANGE GCWR Equal to or Less than 80,000-lb, Higher GCWR May Result in Reduced Engine Performance While Operating in Extreme Hot Weather Conditions

CLUTCH Omit Item (Clutch & Control)

ANTI-FREEZE Red, Extended Life Coolant; To -40 Degrees F/ -40 Degrees C, Freeze Protection

202

PTO EFFECTS, ENGINE FRONT Less PTO Unit, Includes Adapter Plate on Engine Front Mounted

ENGINE, DIESEL {Cummins X15 470 V} Productivity Series, EPA 2021, 470HP @ 1900 RPM, 1750 lb-ft Torque @ 950 RPM, 2000 RPM Governed Speed, 482 Peak HP (Max)

FAN DRIVE {Horton Drive master} Two-Speed Type, Direct Drive, with Residual Torque Device for Disengaged Fan Speed

Includes

FAN Nylon

AIR CLEANER Single Element, with Integral Pre-Cleaner, Integral Snow Valve and In-Cab Control, Engine Mounted

FEDERAL EMISSIONS {Cummins X15} EPA, OBD and GHG Certified for Calendar Year 2021

FAN OVERRIDE Manual; with Electric Switch on Instrument Panel, (Fan On with Switch On)

HOSE CLAMPS, RADIATOR HOSES, Mechanical Type; with Constant-Tension Functionality

FAN DRIVE SPECIAL EFFECTS Fan Cooling Ring with Fan Shroud Effects, Engine Mounted

RADIATOR DRAIN & FILL FITTING SPECIAL; To Vacuum Out or Fill the Cooling System from the Bottom of Radiator, for Use with Quick-Connect Radiator Drain Tool or Shop Coolant Evacuation-Fill System

EMISSION COMPLIANCE Federal, Does Not Comply with California Clean Air Idle Regulations

RADIATOR Aluminum, Welded, Cross Flow, Front to Back System, 1084 SqIn, with 866 SqIn Charge Air Cooler

Includes

RADIATOR HOSES Premium, Rubber

TRANSMISSION, AUTOMATIC {Allison 4700 RDS} 5th Generation Controls, 7 Speed with Double Overdrive, with PTO Provision, Less Retarder, Includes Oil Level Sensor, On/Off Highway, with Two Speed Reverse

OIL COOLER, AUTO TRANSMISSION {Champ} Remote Mounted

TRANSMISSION SHIFT CONTROL Column Mounted Stalk Shifter, Not for Use with Allison 1000 & 2000 Series Transmission

TRANSMISSION OIL Synthetic; 63 thru 76 Pints

ALLISON SPARE INPUT/OUTPUT for Rugged Duty Series (RDS) and Regional Haul Series (RHS), General Purpose Trucks, Construction, Package Number 223

SHIFT CONTROL PARAMETERS {Allison} 3000 or 4000 Series Transmissions, Performance Programming

AXLE, REAR, TANDEM {Meritor RT-46-164EH} Single Reduction, Standard Width, 46,000-lb Capacity, Driver Controlled Locking Differential in Forward-Rear and Rear-Rear Axle, 200 Wheel Ends . Gear Ratio: 5.38

SUSPENSION, REAR, TANDEM {Chalmers 854-46H} Walking Beam, 46,000-lb Capacity, 54" Axle Spacing, Rubber Springs, with (8) Torque Rods, Restrictor Cans

FUEL TANK STRAPS Bright Finish Stainless Steel

FUEL/WATER SEPARATOR {Racor} Fuel Pre-Filter and Filter Base, Includes Water-In- Fuel Sensor

FUEL HEATER {Cummins} Plumbing for Thermal Recirculation Valve (TRV) Mounted to Cummins X15 Engines, Thermostatically Controlled

FUEL TANK Non-Polished Aluminum, 24" Dia, 80 US Gal (303L), Mounted Left Side, Under Cab

DEF TANK 10.6 US Gal (40L) Capacity, Frame Mounted Outside Left Rail, Under Cab CAB Conventional, Day Cab

Includes

CAB REAR SUSPENSION Air

CLEARANCE/MARKER LIGHTS (5) LED Roof Mounted

COAT HOOK, CAB Located on Rear Wall, Centered Above Rear Window

CONSOLE, CENTER Includes Two Cup Holders and One Additional Storage Area

CONSOLE, OVERHEAD Molded Plastic with Dual Storage Pockets, Retainer Nets and CB Radio Pocket; Located Above Driver and Passenger

COURTESY LIGHT (2) Driver and Passenger Door Mounted

DOME LIGHT, CAB Rectangular, Door and Instrument Panel Mounted Switch Activated, Timed Theater Dimming, Center Mounted, Integral to Console

FLOOR COVERING Rubber, Black

GLASS, ALL WINDOWS Tinted

GRAB HANDLE, CAB INTERIOR (1) "A" Pillar Mounted, Passenger Side

GRAB HANDLE, CAB INTERIOR (4) "B" Pillar and Door Mounted, Two Each Side

READING LIGHT, CAB Located in Overhead Console

STORAGE POCKET, DOOR (2) Full Length, Driver and Passenger Door

AIR CONDITIONER with Integral Heater and Defroster

Includes

HOSE CLAMPS, HEATER HOSE Mubea Constant Tension Clamps

GAUGE CLUSTER Premium Level: English with English Speedometer and Tachometer, for Air Brake Chassis, Includes Engine Coolant Temperature, Primary and Secondary Air Pressure, Fuel and DEF Gauges, Oil Pressure Gauge, Includes 5 Inch LCD Color Display

Includes

GAUGE CLUSTER DISPLAY, Odometer, Voltmeter, Diagnostic Messages, Gear Indicator, Trip Odometer, Total Engine Hours, Trip Hours, MPG, Distance to Empty/Refill for Fuel/DEF, DPF Level

IP CLUSTER DISPLAY On Board Diagnostics Display of Fault Codes in Gauge Cluster

SEAT, DRIVER {ISRI} Series 300, Air Suspension, High Back, Mordura, Single Chamber Lumbar, Inboard Armrest, Suspension Cover, Fore/Aft Isolator, Cushion Extension, Seat Tilt

GRAB HANDLE, EXTERIOR (2) Chrome, Towel Bar Type, with Anti-Slip Rubber Inserts, for Cab Entry Mounted Left and Right Side at B-Pillar

SEAT, PASSENGER {Seats, Inc.} Non Suspension, High Back, Fixed Back, Integral Headrest, Mordura Cloth, for use with Batteries in Cab

MIRRORS (2) C-Loop, Power Adjust, Heated, LED Clearance Lights, Bright Headsand Arms, 7.5" x 14" Flat Glass, Includes 7.5" x 7" Convex Mirrors, for 102" Load Width

Notes

Mirror Dimensions are Rounded to the Nearest 0.5"

MIRROR, CONVEX, HOOD MOUNTED (2) Right and Left Sides, Bright, 7.5" x 7"

CAB INTERIOR TRIM Diamond, for HX Day Cab

Includes

DOOR TRIM, INTERIOR Bright Handle

INSTRUMENT PANEL TRIM Black, Black Gauges with Black Bezels

SUN VISOR (2) Padded Vinyl; 2 Moveable (Front-to-Side) Primary Visors, Driver Side with Toll Ticket Strap

WINDSHIELD Heated, Single Piece

HOSE CLAMPS, HEATER HOSE {Breeze} Belleville Washer Type

WINDOW, POWER (2) and Power Door Locks, Left and Right Doors, Includes Express Down Feature

MODESTY PANEL Painted Body Color, with LED Lights, for Day Cab

INSTRUMENT PANEL Wing Panel

ACCESS, CAB Aluminum, Driver & Passenger Sides, Two Steps per Door, for use with Day Cab or Sleeper Cab

SUNSHADE, EXTERIOR Bright Finish, with Integral Clearance/Marker Lights

WINDSHIELD WIPER BLADES Snow Type

WHEELS, FRONT {Alcoa 89U63} DISC; 22.5x9.00 Rims, Mirror Polish Aluminum, 10- Stud, 285.75mm BC, Hub-Piloted, Flanged Nut, with Steel Hubs, Non-Standard Offset 4.06"

WHEELS, REAR {Accuride 42644} DUAL DISC; 22.5x8.25 Rims, Standard Polish Aluminum, 10- Stud, 285.75mm BC, Hub-Piloted, Flanged Nut, with Steel Hubs

(8) TIRE, REAR 11R22.5 Load Range H ARMOR MAX MSD (GOODYEAR), 493 rev/mile,
68 MPH, Drive

(2) TIRE, FRONT 315/80R22.5 Load Range L G289 WHA (GOODYEAR), 484 rev/mile,
68 MPH, All-Position

Services Section:

WARRANTY Standard, Effective with Vehicles Built January 1, 2024, or Later, CTS-2015B
Please list any extended Warranty Available and cost as an option.

PAINT: Cab, Red

202

Base Chassis with 215.00 Wheelbase, 125.00 CA, and 75.00 Axle to Frame.

CROSSMEMBER, FRAME TIE for Standard Duty
AXLE CONFIGURATION} 6x4

Notes

Pricing may change if axle configuration is changed

FRAME RAILS Heat Treated Alloy Steel (120,000 PSI Yield) Galvanized if available; 12.50" x 3.750" x 0.500" (317.5mm x 95.25mm x 12.7mm); 480.8" (12212mm) Maximum OAL

BUMPER, FRONT Swept Back 40-Degrees, Steel, Painted, Heavy Duty

FRAME EXTENSION, FRONT Integral; 27" in Front of Grille, Includes Crossmember for Front PTO

WHEELBASE RANGE 211" (535cm) Through and Including 256" (650cm)

AXLE, FRONT NON-DRIVING {Meritor MFS-20-133A} Wide Track, I-Beam Type, 20,000-lb Capacity

SUSPENSION, FRONT, SPRING Parabolic Taper Leaf, Shackle Type, 20,000-lb Capacity, Steel Springs 18K Capacity and (2) Rubber Auxiliary Springs 2K Capacity, Less Shock Absorbers, Right side Auxiliary spring for plow application

BRAKE SYSTEM, AIR Dual System for Straight Truck Applications Includes

BRAKE LINES Color and Size Coded Nylon

PARKING BRAKE CONTROL Yellow Knob, Located on Instrument Panel

PARKING BRAKE VALVE For Truck

QUICK RELEASE VALVE On Rear Axle for Spring Brake Release: 1 for 4x2, 2 for 6x4

SPRING BRAKE MODULATOR VALVE SR-7 with relay valve for 6x4/8x6

TRAILER CONNECTIONS Four-Wheel, with Hand Control Valve and Tractor Protection Valve, for Straight Truck

AIR BRAKE ABS {Bendix Antilock Brake System} 4-Channel (4 Sensor/4 Modulator) Full Vehicle Wheel Control System

AIR DRYER {Bendix AD-HF} with Heater, Includes Pressure Protection Circuits, Safety Valve, Integral Purge Tank, Governor Pressure Settings 110 psi Cut-In/130 psi Cut-Out

BRAKE CHAMBERS, REAR AXLE {Bendix Ever Sure} 30/30 SqIn Spring Brake

BRAKE CHAMBERS, FRONT AXLE {Bendix} 24 SqIn

SLACK ADJUSTERS, FRONT {Gunitite} Automatic

SLACK ADJUSTERS, REAR {Gunitite} Automatic

AIR COMPRESSOR {Cummins} 18.7 CFM

AIR TANK Painted Aluminum, with Straight Thread O-Ring Ports

AIR DRYER LOCATION Mounted Inside Left Rail, Back of Cab DUST

SHIELDS, FRONT BRAKE for Air Cam Brakes



ORDER ENTRY # _____

QUOTATION

6 ENTERPRISE DRIVE
LONDONDERRY, NH 03053
PHONE: 603-669-2250
FAX: 603-669-0501

P.O. # _____

QUOTE / ORDER # SC01262

CUSTOMER: HENNIKER NH HIGHWAY DEPARTMENT
CONTACT: LEO
ADDRESS: 18 DEPOT HILL RD
HENNIKER NH 03242
PHONE: 603-428-3221
EMAIL: ROADAGENT@HENNIKER.ORG

DATE: 2/7/24
TRUCK INFO:
VIN #: _____
YEAR: 2025
MAKE: IHC
MODEL: 10 WHEELER
CA/CT:
TRANS:

BODY SR. # _____ HOIST SR. # _____ COLOR BLACK

"MG" 4-SEASON BODY 14' LENGTH 42" SIDES 58" TAILGATE
1/4" HARDOX 450 FLOOR & TAILGATE 3/16" HARDOX 450 SIDES & FRONT
6 PANEL DOUBLE ACTING AIRGATE WITH 1-1/4" FLAME CUT HARDWARE
10" I-BEAM/1/4" HARDOX CONVEYOR LID
24" CAB PROTECTOR - DRIVER SIDE FRONT STEPS
REAR CORNER POST .304 STAINLESS STEEL/CENTRAL GREASE SYSTEM
BARFLIGHT EVERY LINK/TWO GREASE CYLINDERS FOR CHAIN TENSION
MANUAL DISCHARGE GATE IN LEFT FRONT OF THE BODY
DEFLECTOR CHUTE & SPINNER ASSEMBLY WITH QUICK DISCONNECTS
POLY DEFLECTOR CHUTE - URETHANE DISC. - BAFFLES
MAILHOT G4-130-5-3- FRONT MOUNT TELESCOPIC PISTON - (2 YEAR WARRANTY)
FOUR 4" X 22" D/A TILT CYLINDERS FOR FLOOR WITH FLOW DIVIDER
SAFETY PROP FOR FRONT HOIST & TILT CYLINDERS/4 PIECE H/D TOP SCREENS
ALL LIGHTS AND REFLECTORS TO MEET FMVSS-108
BACKUP ALARM / BODY RAISE INDICATOR / FRONT (ANTI SAIL) & REAR MUD FLAPS
FOLD UP LADDER & SHOVEL HOLDER D/S FRONT

FRONT MOUNT CRANK SHAFT DRIVEN HYDRUALICS TO RUN: DUMP/SIDE TIP/PLOW LIFT/PLOW
ANGLE/WING HEEL/WING TOE. DELL FEATHER AIR CONTROLS. CERTIFIED CIRUS EZ SPREAD ELECTRIC
SANDER CONTROL VALVE PIPED TO REAR W/ QUICK DISSCONNECTS. FRAME MOUNTED HYDRUALIC TANK
W/SITE GAUGE. STAINLESS STEEL HYDRAULIC LINES. VALVES TO MOUNTED BEHIND THE CAB ON THE P/S.

- 11' MONROE POWER REVERSE FULL TRIP PLOW PIN TYPE (MP41R11-ISCT)
W/ RUBBER DEFL/KUPER CARBIDE CUTTING EDGE
- 11' MONROE PATROL WING W/ 10' KUPER CARBIDE CUTTING EDGE/CURB GUARD
- MONROE POWER TILT PLOW HITCH W/ WING TUBES
- 30 TON HOOK ON 3/4" PLATE W/ DRINGS & PLUG
- AERO ELECTRIC COVERALL W/ ALUMINUM ARMS/MESH NET/TENSION HOOP
- MINI LIBERTY LED LIGHT BAR MOUNTED ON RACK ABOVE CAB # IT9AAAP
- 4 HEATED LED STROBES IN REAR/2 FACING REAR/2 ON SIDES/2 HEATED LED REVERSE LIGHTS
- 5 HEATED ABL LED WORK LIGHTS/2 TO TURN ON WHEN IN REVERSE
- ABEL HEATED LED PLOW LIGHTS
- TURNBUCKLE TAILGATE SAFTEY LOCKS
- SIDE BOARDS 8"X2" BOX TUBING

TOTAL INSTALLED \$ 124,655.00

I HAVE READ AND APPROVED THE ABOVE QUOTATION AND
HEREBY AUTHORIZE YOU TO COMPLETE THE WORK.

CUSTOMER SIGNATURE: _____ DATE: _____

NOTE: PAYMENT IS DUE IN FULL UPON DELIVERY. NO CREDIT CARDS ACCEPTED.

QUOTATION IS VOID AFTER 45 DAYS.

QUOTED BY: SCOTT COVATIS



Viking-Cives of Vermont
74 Armand Lane

Willison, VT 05495
Phone: (802) 660-9991
Fax: (802) 660-9992
www.vikingcives.com

QUOTATION

Error! Reference
Quote ID: source not found.

Page 1 of 2

Customer: Town of Henniker
209 Ramsdell Road
Henniker, NH 03242

Quote Number: Henniker
Quote Date: 02/07/24
Quote valid until: 06/07/24

Contact: Leo Aucoin
Phone: 603-428-7200

Salesperson: Mike Murray

Part Number	Description	Quantity	Unit Price	Amount
	Power Tilt Hitch w/Wing Mount and Twin Chain Tilt	1		
	FAH48 Hydraulic Front Mast w/Ribbed Slide (Welded On)	1		
	Timbren Hinge – 10 Degree	1		
	H1096V Hydraulic Shelving Support w/Detachable 3 Point	1		
	1011WHD Wing w/Black Paint	1		
	HD Timbren Trip Hydraulic Arms (Cushion Spring Lower)	1		
	HD Sabre Blades	1		
	Carbide Moldboard Shoes (Pair)	1		
	HD Curb Guard	1		
	PRR1142SE Slotted Trip Reversing Moldboard w/Black Paint	1		
	Slotted Spring Trip Hydraulic Reversing Drive Frame	1		
	Two Chain Lift	1		
	Standard Push Lug Swivel	1		
	HD Sabre Blades	1		
	Carbide Inserted Frame Shoes (Pair)	1		
	Rubber Deflector and Fluorescent Whip	1		
	Front Mounted Tandem Gear Pump w/Electric Clutch	1		
	Behind Cab Mounted Oil Reservoir w/Low Oil Sensor	1		
	7 Section Load Sharing/Proportional Implement/Spreader Valve	1		
	Cable Actuated Implement Controls	1		
	EZ Spread 2 Electronic Spreader Control w/Valve	1		
	Stainless Steel Hydraulic Piping to the Front and Rear	1		
	PLSD14' Side Dump w/Remote Lube, Every Flight Chain	1		
	¼" AR450 Floor/Tipper w/I-Beam Long and Cross Members	1		
	AR450 Driver's Wall and Structural/Safety Wall	1		
	Nine Panel AR450 Tailgate w/Air Release and Manual Locks	1		
	½ Cab Shield	1		
	SA Telescopic Hoist	1		
	Three Point Ladder, Gearbox Step, and Inner Body Step	1		
	Shovel Holder	1		
	Electric Cover w/30 Deg Alum Arms, Mesh Tarp, Tensioner	1		
	Tubular Steel Sideboards	1		



Viking-Cives of Vermont
74 Armand Lane

Willison, VT 05495
Phone: (802) 660-9991
Fax: (802) 660-9992

www.vikingcives.com

QUOTATION

**Error! Reference
Quote ID: source not found.**

Page 2 of 2

Part Number	Description	Quantity	Unit Price	Amount
	Pintle Plate w/30 Ton Hook, Electrical Plug, and Glad Hands	1		
	Front & Rear Mud Flaps w/Anti Sails on Front	1		
	Shot Blasted, Zinc/Epoxy Primed, and High Temp Baked	1		
	Painted Dupont Imron Black and High Temp Baked	1		
	LED Mini Justice Light Bar and LED Heat Corner (4) Strobes	1		
	LED Heated Stop/Tail/Turns and Back Ups and LED Markers	1		
	LED Heated Plow Lights	1		
	LED Heated Spot Lights	5		
Quote Total:				\$110,800.00
Trade:				
Total Due:				\$110,800.00

The following items may be added:

Part Number	Description	Quantity	Unit Price	Amount
	Installation on IH HX Chassis in Lieu of Other Models	1	\$800.00	\$800.00

Customer must fill out the information below before the order can be processed...

<i>Accepted by:</i>	
<i>Date:</i>	
<i>P.O. number:</i>	

- The price and terms on this quotation are not subject to verbal changes or other agreements unless approved in writing by the seller. All quotations and agreements are contingent upon strikes, accidents, fires, availability of material, and all other causes beyond our control. Prices are based on cost and conditions existing on the date of quotation and are subject to change by the seller before final inspection.
- Typographical and stenographic errors are subject to correction.
- Conditions not specifically stated herein shall be governed by the established trade customs. Terms inconsistent with those stated herein which may appear on purchaser's final order will not be binding on the seller.
- Terms are due upon receipt unless prior credit has been established or established accounts are set up with Net 30-day terms.
- Quoted price does not include any applicable taxes and is subject to state and local tax, as well as Federal excise tax unless proper forms are submitted and established when applicable.
- All orders are FOB Viking facility unless noted otherwise.

Notes:

Town of Henniker, N.H. Plows and Body Bid Specifications 2021

Hitch and Wing System

	<u>Yes</u>	<u>No</u>	<u>Deviations</u>
Hitch to be of "power tilt" design.	✓	—	_____
The hitch shall tilt forward hydraulically to provide engine access.	✓	—	_____
Two horizontal tubes shall extend outward to the passenger side of the chassis to serve as support for the front wing post.	✓	—	_____
The front wing post shall be welded to the hitch.	✓	—	_____
The front wing post shall raise the nose of the wing a minimum of 48" by use of a direct hydraulic lift.	✓	—	_____

Cable post is Unacceptable.

	<u>Yes</u>	<u>No</u>	<u>Deviations</u>
There will be a 30-degree wing trip block.	✓	—	_____
The rear post shall be a Semi-Detachable, with 36" of hydraulic lift.	✓	—	_____
The rear post shall be properly braced and attached to the chassis frame rail.	✓	—	_____
A steel support shall tie both chassis frame rails together with the rear post.	✓	—	_____
The rear wing post shall have a three point attachment for push arms and lift cylinder attachment.	✓	—	_____
Push arms are adjustable in length to provide variable clearing paths.	✓	—	_____
The bottom arm shall incorporate a compression spring to aid in protecting the wing components.	✓	—	_____
A double acting lift cylinder shall be mounted between the arms to provide rear of wing lift.	✓	—	_____
A 30-degree wing trip block, shall be mounted between the nose of the wing and the front post to attach the wing.	✓	—	_____
All hitch and wing mount gear shall be sandblasted, epoxy primed and painted black.	✓	—	_____

Wing

	<u>Yes</u>	<u>No</u>	<u>Deviations</u>
Cutting edge length: 10'	✓	—	_____
Overall Length: 11'	✓	—	_____
Moldboard will be roll formed and constructed from a minimum of seven (7) gauge <i>Hi-Tensile steel</i> and reinforced with full length ribs.	—	✓	<i>Brake formed.</i>
The wing shall be punched 12" on center.	✓	—	_____
Wing shall come complete with KUPER XT Armored carbide blade, one KUPER SX carbide curb shoes and carbide moldboard shoes.	—	✓	<i>HD Sabre blades and shoes.</i>
The wing shall be sandblasted, epoxy primed, and painted black in the rear.	✓	—	_____

Plow

	<u>Yes</u>	<u>No</u>	<u>Deviations</u>
Shall be a Full trip hydraulic reversing plow, with a 3/16" Hi-tensile steel moldboard and a slotted canister trip mechanism.	✓	—	_____
Cutting edge length: 11'	✓	—	_____
	—	—	_____
	—	—	_____

Moldboard will be roll formed and constructed from a minimum of seven (7) gauge *Hi-Tensile steel* and reinforced with full length ribs.

✓

Brake formed

The leading edge of the plow shall have a rubber deflector and one fluorescent wire plow guide.

✓

Plow shall be punched 12" on center.

✓

Plow shall come complete with KUPER XT

Armored carbide blade, and carbide frame shoes.

✓

HD sabre blades.

The lifting device shall be dual chain.

✓

Moldboard steel shall

painted black on the rear side.

✓

Drive frame steel shall be sandblasted, primed with an epoxy primer and painted black.

✓

Hydraulics

Yes

No

Deviations

A Tandem gear pump with an electronic clutch keyed not splined (no exceptions), the pump shall power all hydraulic functions.

✓

A Seven section valve for implement and spreader functions shall be mounted behind the cab on the passenger side of the chassis.

✓

All implement and spreader lines shall be plumbed with stainless steel tubing and short hose whips.

✓

Implement controls shall be run by Dell feathered air plow/wing & body controls.

✓

The controls will be mounted on a pedestal in the cab with the Town's approval for location.

✓

Spreader system functions shall be run with a Certified Cirrus EZ Spread electronic sander control. No exceptions.

✓

A minimum 40 gallon steel oil reservoir with return line filtration and ball valve shut off shall be mounted behind the cab on a pedestal.

✓

There will be a low hydraulic oil level alarm in the cab of the truck.

✓

Combination Spreader/Dump Body

Yes

No

Deviations

Heavy duty body serving as a spreader or dump body transformed by a *single wall* hydraulic tilting floor.

✓

Inside length: 14'

✓

Capacity: 12.35 cu/yd to 16 cu/yd with sides

No taller than 39" and a tail gate no taller than 52"

✓

Hoist cylinder; Mailhot, Single acting telescopic

✓

Cab shield: 24" overhang

✓

The entire body will be constructed from 1/4" & 3/16" Hardox 205,000 psi Hi-Tensile steel.

✓

Standard AR400 is not acceptable, it must be Hardox 450.

✓

The tailgate will be double acting, six panel, and constructed from 1/4" Hardox 205,000 psi steel.

✓

9 panel tailgate.

Tailgate shall be air operated and shall latch and unlatch with a double acting air cylinder. Tailgate will be equipped with locks on both sides

✓

The floor shall be constructed of 1/4" **Hardox**
high tensile steel with a minimum
205,000 psi tensile strength.

The sides and front will be constructed of 3/16"
Hardox with a minimum 205,000 psi steel strength.

The understructure of the body shall consist of two
10" longitudinal I-beams.



The complete body shall have a central lube kit, with all grease points brought out to the edge of the body.

✓

The side tilt floor shall be raised to reload the conveyor by use of two double acting cylinders.

The conveyor is an integral part of the body floor and runs longitudinally down the driver's side of the body, discharging in front of the rear wheels.

✓

There shall be a 1/4" Hardox 205,000 psi three section chain cover.

✓

✓

2 section.

The chain shall contain bar flights every link for greater strength and consistent material flow.

✓

A rear access plate with access to the conveyor chain in the rear apron.

✓

✓

Under rear chain door.

All chain links are protected by an integral chain guard leaving only the bar flights exposed.

✓

The chain shall be driven by a 25:1 ratio gearbox.

✓

The spinner shaft has a top mounted bi-rotational hydraulic motor to spin an 18" poly disc.

✓

The spinner assembly is chassis mounted and is both laterally and vertically adjustable and removable.

✓

A poly chute feeds the spreading disc. The chute is both adjustable and removable.

✓

All body parts will be Primed with rust inhibiting Epoxy primer and painted with epoxy Black.

✓

All hydraulic lines on the body will be 1/2" I.D. #304 stainless steel. Black iron pipe will not be accepted.

✓

Rear corner posts will be constructed of #201 stainless steel.

✓

✓

3/16" Corten steel. Blasted, zinc primed, epoxy primed, baked, painted, and baked again.

Sideboards to be constructed of 1/4 inch by 8 inches by 2 inches box tubing with welded caps on all ends

✓

Required Options

Yes

No

Deviations

The body shall have a fold up ladder with grip steps and a handle for 3 points of contact.

✓

A 3/4" pintle plate shall be installed with 2 D-rings, Primed and painted A 30-ton swivel pintle hook, and an EZ connector trailer plug.

✓

A shovel holder shall be installed.

✓

Front and rear mud flaps with anti-sail brackets on the front pair.

✓

A body UP indicator in the cab.

✓

An inner body step and handle.

✓

A Roll Rite Electric Load cover with a Tension bar and a mesh tarp.

✓

Lighting

Strobe system shall include a mini liberty LED bar light mounted on a rack above the cab,

four Heated LED rear corner post mounted amber warning lights. Two facing to the rear and two to the side.

✓

Stop/tail/turns and back up lights will be

Heated LED.

✓

Five Heated ABL LED work lights shall be supplied and installed with the Town's approval.

✓

The two rear facing work lights will turn on automatically when the truck is shifted into reverse.

✓

ABL LED heated plow lights shall be installed.

✓

Please state what your warranty is: 1 year



Commercial warranty for 4-Seasons MG DUMP BODIES

NEW LIMITED COMMERCIAL WARRANTY

COVERAGE AND DURATION

Équipements TWIN (Laval) Inc. warrants to the original purchaser of an MG 4-Seasons product that the steel structure of the dump body will be, for a period of five (5) years after its original date of purchase, free from defects in material and workmanship. This warranty does not guarantee that the product will be defect-free. The warranty on our product, based on normal use and service, is limited to the replacement or repair, at our factory, of all parts that will be returned to us, and that, after examination, have been found to be defective.

As for the other components delivered with an MG 4-Seasons dump body, including paint if applicable, Équipements Twin (Laval) inc. warrants to the original purchaser, for a period of one (1) year after its original date of purchase, that these will be free of any defects in material and workmanship. This warranty does not guarantee that the product will be defect-free. The warranty, according to normal use and service, is limited to the replacement or repair, at our factory, of all parts that will be returned to it, and that, after examination, have been found to be defective.

EXCLUSIONS

1. No refund or allowance will be granted for any work and repair carried out by other persons or companies other than Équipements Twin (Laval) Inc. and/or one of its dealers. However, it is possible to carry out certain work under warranty in a workshop, by obtaining prior authorization.
2. The company Équipements Twin will not be responsible for any sum that may be claimed for loss of use or any other claim that may result indirectly from a defect covered by the warranty.
3. The warranty may be refused if a breakage occurs because the recommended restrictions for pump installation, flow pressure and galonage have not been respected.
4. Excluded from this warranty is any material incorporated into the manufacture of Twin Equipment Inc. products already covered by the warranty of another manufacturer. In the event of a defect in such equipment, the buyer may contact a representative of Équipements Twin or directly the manufacturer of the component to enforce his warranty. The address of such

ADRESSE SUCCURSALE

2025, Rue Le Chatelier, Laval (Québec) H7L 5B3 T 514 353-1190 SF 877 300-8946 F 514-353-1119 info@twin.ca

ADRESSE CORRESPONDANCE

10401, Boulevard Parkway, Ville d'Anjou (Québec) H1J 1R4



manufacturer to make the extent of the warranty will then be provided by Équipements Twin on request.

5. The warranty becomes ineffective if the user does not comply with the maintenance set by Équipements Twin (Laval) inc., including those set out in the maintenance manual.

Whether during or after the warranty period, it is strongly suggested never to leave a defective part in operation, but to make the change as soon as possible. A delay in changing a defective part may result in breakage or malfunction and/or premature wear of other parts. This is also true for all parts and components of the box.

WARRANTY PROCEDURE

1. Prior authorization from Équipements Twin (Laval) inc. must be obtained for all warranty work.
2. Contact our authorized distributor or Twin Equipment with full details of your request, i.e. the unit in question, including the serial #, the date of purchase, from whom it was purchased, as well as the nature of the reason for your claim.
3. A claim # will be assigned to you, and is required, whenever a warranty must be paid in the form of credit, replacement parts, or service work. The assignment of a serial # does not guarantee that the warranty will be authorized. This # is to identify your request and allow tracking of parts that could be returned.
4. When warranty replacement parts are shipped, we may ask you to return the defective parts to us for inspection by Twin Equipment or the original manufacturer. In these cases, you will be charged for freight of shipping the replacement part to us until receipt of the defective part, at which time the freight charges will be credited to you.

Effective _____ # Series ____

info@twin.ca 1-877-300-7500

January 1, 2023

Monroe Truck Equipment Municipal Customers

July 12th, 2023

**Monroe Truck Equipment Municipal
Manufacturing Warranty & Return Policy as of July of 2023****This policy stands true of all excess and warranty parts that are to be returned to Monroe Municipal Manufacturing for credit.**

All returns must be pre-approved and are subject to the discretion of Monroe Truck Equipment's Municipal Manufacturing Warranty Department.

Returns are subject to an up to a 15% re-stock fee. A re-stock fee will not be applied to any warranty defects.

To obtain approval for a parts return, or warranty claim, call Monroe Truck Equipment's Municipal Manufacturing Warranty Department at 608-329-8544 or 800-880-0109 ext. 544 or email to Dan.Tuscan@aebi-schmidt.com.

When calling to request an RMA for a parts return, please have the following information ready: Original invoice number, part number, quantity, and serial number if applicable.

You will receive an RMA form by email, that must be included with the return. Also, you must print the RMA number on the outside of the return.

When calling to request a warranty number for a claim, please have the following information ready: Original invoice number, serial number, part number, quantity, VIN number (if available), phone number and e-mail address.

For a defective vendor part, a warranty number will be created.

- A new part will be sent to replace the defective part.
- Additional defective part info will be needed. This may be a serial number or other markings on the product.
- MTE will obtain an RGA number from the vendor for the defective part.
- The part will need to be boxed and ready for shipment. MTE will create a call tag to have the part picked up and returned to the vendor.

For a defective MTE Municipal manufactured part, a warranty number will be created.

- The warranty team will work with the customer to determine the defect in the part.
- A new part will be provided or labor to repair the part in question.
- A decision on returning the defective part will be made at that time.
- If returned an RMA will be e-mailed to the customer. This must be included with the return part.



Anything sent back without an RMA form and/or approval from Monroe Truck Equipment's Municipal Manufacturing Warranty Department will be sent back, freight pre-paid and billed to your account.

Warranty labor must be pre-approved and will be paid at a labor rate of \$____ per hour. Warranty policy does not cover travel expenses or mileage.

We do not accept returns of vendor parts over 6 months old, manufactured parts over 12 months old or special-order parts.

From the date the warranty number was issued, you will have 30 days to return the parts, or the warranty number will be canceled. Special circumstances will be considered.

Freight costs incurred to return excess or warranty parts are the responsibility of the customer sending the return. Freight costs that are to be credited will be made at ground costs only.

Credit will be issued upon inspection of the returned parts. If parts are deemed in condition not appropriate for re-sell, we will contact you. For a warranty return the customer will be charged for the new parts being shipped. A credit will be issued when the defective parts or correct parts are approved by the vendor. Credit notification will be given within 30 days after receipt of the parts.

Please see warranty policies for uninstalled parts and equipment. This will be included in the warranty packet and in your Monroe Truck Equipment parts manuals.

Vendor parts such as cylinders and motors will not be covered by warranty if welded on or taken apart. This is the warranty coverage of the vendor and is supported by MTE.

Monroe Truck Equipment reserves the right to change this policy at any time without notification.

Electronic equipment will not be considered for parts return.

All returns are to be sent to:
Monroe Truck Equipment, Inc.
ATTN: Dan Tuscan
1051 W. 7th Street
Monroe, WI 53566

DONOVAN

LIMITED WARRANTY POLICY

Donovan Equipment Co., Inc. warrants its products sold and installed at its facility in Londonderry, NH to be free of defects in material and workmanship under normal use and services.

The warranty covers work performed at Donovan Equipment Co., Inc by its employees and products sold by Donovan Equipment Co., Inc.

Donovan Equipment Co., Inc warrants its workmanship for a period of 12 months, commencing from the date of purchase.

- Exceptions:**
- 1) Hydraulic; PTO, Pump, Hoses and Fittings are Warranted for 90 days
 - 2) Paint is warranted for 90 days
 - 3) Heated Bodies; Due to the exhausts extreme temperature Donovan Equipment Co., Inc cannot warranty the paint on Heated Bodies.

This warranty is offered to the original purchaser only and is not transferable (excluding Truck Dealer).

This warranty is expressly limited to the work performed and products sold at Donovan Equipment Co., Inc. All products produced by others (The Original Equipment Manufacturer) will be warranted by their respective manufacturer and are subject to their terms and policy.

All warranty claims must be evaluated and authorized by the management of Donovan Equipment Co., Inc and all warranty work must be performed at Donovan's facility by Donovan Employees. **Customer is responsible for transport of the truck to and from our facility.**

Any work performed without pre-authorization of Donovan Equipment Co., Inc. voids this warranty. Changes, alteration or any other modifications to products and equipment as delivered by Donovan Equipment Co., Inc. voids this warranty.

Donovan Equipment Co., Inc. shall not be held liable for special, incidental or consequential damages of any nature, including but not limited to, lost opportunities, warranties of merchantability, fitness for a particular purpose, misuse or improper use of our products.



BLOG

[Suppliers Portal](#) [Sign Up](#) [About us](#) [Category](#) [Dimensions](#)
[ASTM](#) [Contact Us](#)

[ThePipingMart Blog](#) [Metals](#)

[Hardox vs AR Steel – What's the Difference](#)

Hardox vs AR Steel – What's the Difference

📅 August 15, 2023 | ⌚ 11:40 am

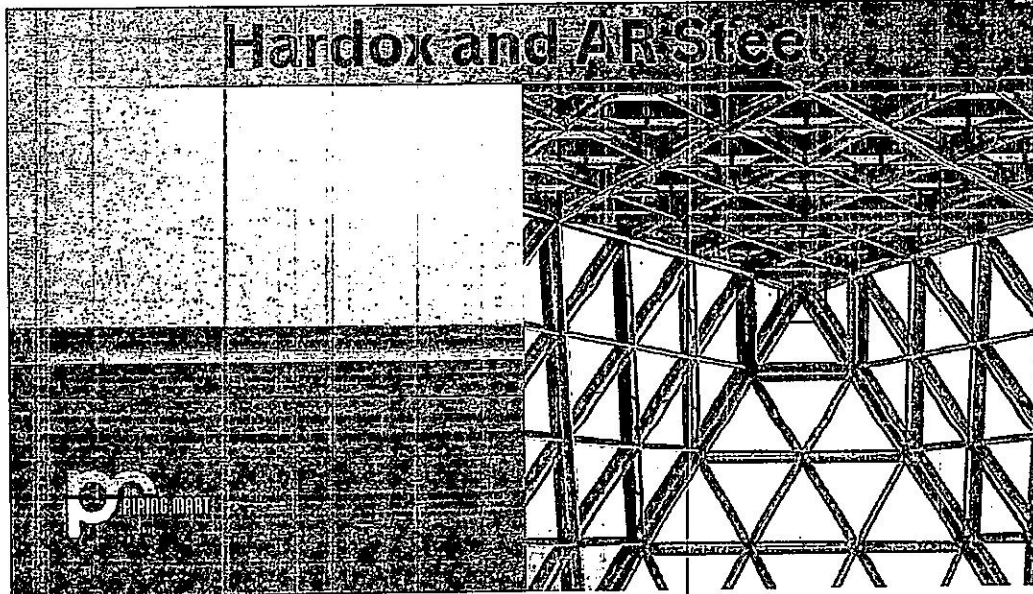

When choosing the right steel grade for a specific application, it's important to consider all the factors involved. Two of the most common steel grades are Hardox and AR, and while they share some similarities, they also have specific differences that set them apart. So, what are the differences between Hardox and AR steel? In this article, we'll take a closer look at both types of steel and compare them in various aspects.

What is Hardox?

Hardox is a wear-resistant steel ideal for challenging conditions with a risk of abrasion, impact, or sliding wear. It's used in mining, construction, and recycling industries and offers excellent toughness, durability and resistance to wear. One key difference between Hardox and AR steel is that Hardox is specifically designed to withstand extreme wear and tear. In contrast, AR steel is more general-purpose steel used in various applications. Hardox is also more resistant to cracking and surface damage than AR steel, making it more suitable for bending, drilling, or welding processes.

What is AR?

AR steel is a high-carbon steel known for its strength and hardness. It's often used in applications where toughness and durability are important, such as in the construction of heavy equipment and machinery. The 'AR' in AR steel stands for 'Abrasion Resistant', which means the steel is resistant to wear and tear caused by abrasion. However, it's important to note that AR steel has a lower resistance level than Hardox to certain types of wear, such as impact or sliding wear. AR steel is also more prone to surface damage and cracks, especially when exposed to high-stress conditions.

Difference Between Hardox and AR Steel

Hardness and Strength

When it comes to hardness and strength, both Hardox and AR steel are strong and durable materials. However, some differences in their physical properties set them apart. For example, Hardox has a higher Brinell hardness rating than AR steel. This means it's more resistant to indentation and deformation caused by rocks or gravel. Hardox also has higher

tensile and yield strength, which means it can support heavier loads and withstand more stress before deformation or failure.

Cost

Another important factor to consider when comparing Hardox and AR steel is cost. Since Hardox is a more specialized and high-performance steel, it's generally more expensive than AR steel. However, the higher cost also means a longer lifespan, reduced maintenance costs, and increased productivity. On the other hand, while AR steel may be more affordable, it may require frequent replacement and maintenance, impacting the project's overall cost in the long run.

Conclusion

In conclusion, Hardox and AR steel have unique properties that make them suitable for different applications. Hardox is ideal for applications where extreme wear and tear are expected, and it offers superior durability and toughness compared to AR steel. AR steel, conversely, is a more general-purpose steel suited for a wide range of applications and known for its strength and hardness. Ultimately, the choice between Hardox and AR steel depends on the application's specific requirements, the expected wear and tear, and the budget constraints. By understanding each steel type's key differences and benefits, you can make an informed decision and choose the right material for your project.



Bhavesh Yadav

Meet Bhavesh, a seasoned blogger with a wealth of knowledge and experience. From metal products manufacturing to retail, Bhavesh has a diverse background in various industries and is dedicated to sharing his insights and expertise with readers.



Town Hall
18 Depot Hill Road
Henniker, NH 03242

Tel: (603) 428-3221
Fax: (603) 428-4366

Incorporated November 10, 1768
"Only Henniker on Earth"

TOWN OF HENNIKER, NEW HAMPSHIRE

STAFF REPORT

DATE: 2/16/2024
TITLE: Paving Contract Extension
INITIATED BY: Leo Aucoin, Highway Superintendent
PREPARED BY: Leo Aucoin, Highway Superintendent
PRESENTED BY: Leo Aucoin, Highway Superintendent

AGENDA DESCRIPTION: The Highway Department and Superintendent would like the Selectboard to accept the paving proposal of Busby Construction for the 2024 construction season with increase. The Town has awarded the contract for three years running to Busby and has been pleased with the outcome of their work.

Although there are no specific amounts listed per road that we will be working on this year, the cost associated with that pricing is based on unit pricing which is included. Before any projects get started the budgetary amount for each road will be forwarded to the Selectboard for discussion. The modest increase in unit pricing was included in this proposal and is based mainly on wages. The Highway Department's primary objective to complete this season is Old Hillsboro Road overlay, Liberty Hill Road overlay, Western Ave. mill and fill, and Bacon Road and Deer Run shim and overlay, which Busby has started, and I would hope to have completed by them. Other projects discussed with the RMC for paving are as follows: Foster Hill Road reconstruction completion, Dodge Hill Road reconstruction, which will include the stretch of West Hopkinton Road from 202/9 to Dodge Hill Road intersection.

Legal Authority:

Financial Details:

Town Administrator Comment: N/A

Suggested Action/Recommendation:

Suggested Motion:

No formal action is required.



Busby Construction Co., Inc.

71 Route 111
Atkinson, NH 03811
P: 603-898-4800
F: 603-898-4808

PROPOSAL

Submitted To: Town of Henniker
Address: 18 Depot Hill Road
City, State, Zip: Henniker, NH 03242
Phone / Fax: 603 428 7200

Date: February 1, 2024
Job Name: Paving 2024
Job Location: Henniker NH
Contact Person: Leo Aucoin

We hereby submit specifications and estimates for the following scope of work:

- 1: Reclaim grade and compact with water @ \$1.75 s/y Blending of stone @ \$.30 s/y
- 2: Binder @ \$86.00 per ton Top @ \$88.00 per ton Hand work @\$165.00 per ton
Capcode berm 6" @ \$13.50 l.f
- 3: Trimming end joints day rate @ \$ 2,250.00
- 4: Shoulder work day rate @ \$ 6,000.00
- 5: Flagger traffic control @ \$55 per hour per flagger

Price based on: **AC @ \$662.5**

- 1 Mobilization
- Traffic control, dust control, and permits by others
- Not responsible for damage due to vibration
- Not responsible for damage to site lighting or irrigation

Terms: Net 30 Days, No Retainage

Busby Construction Co., Inc. reserves the right to charge a 1.5% late fee for all overdue payments.
Busby Construction Co., Inc. reserves the right to charge for attorney fees if needed to collect overdue balances.

Unless a lump sum price is to be paid for the foregoing work and is clearly set forth, it is understood and agreed that prices referred to above are only estimates and that payment shall be made at the stated unit prices on the actual quantities of work performed by the Contractor as determined upon completion of work. Above prices are subject to any applicable taxes.

Any additional work or services, other than those outlined in the "scope of work" above, that become(s) necessary to complete the in-place recycling and/or sub-base preparation will be charged as follows:

Lowbed Rental (portal to portal)	\$ _____ per hour	Dump Truck Rental	\$ 75.00 per hour
Grader Rental (as needed)	\$ 135.00 per hour	Loader / Backhoe Rental	\$ 70.00 per hour
Vibratory Roller Rental	\$ 85.00 per hour	Handwork Grading	\$ _____ per s.y.
Water Truck Rental	\$ 65.00 per hour	Structure Adjustment	\$ _____ per each
Excavator Rental	\$ _____ per hour	Saw cutting	\$ _____ per l.f.

By accepting this proposal, the purchaser acknowledges having read the "Conditions of Sale" on page 2 and further acknowledges having understood same. This proposal may be withdrawn by us if not accepted within 30 days. The above prices, specifications, and conditions are satisfactory and are hereby accepted.

Busby Construction Co., Inc.

Buyer Signature: _____

Authorized Signature: Harold Lafoe

Date: _____

Title: Reclamation Manager



Busby Construction Co., Inc.

9 Pond Lane
Atkinson, NH 03811
P: 603-362-4650
F: 603-362-5051

PROPOSAL

Submitted To: Town of Henniker
Address: 18 Depot Hill Road
City, State, Zip: Henniker, NH 03242
Phone / Fax: 603 428 7200

Date: February 1, 2024
Job Name: Foster Hill Road
Job Location: Henniker NH
Contact Person: Leo Aucoin

We hereby submit specifications and estimates for the following scope of work:

- 1: Reclaim grade compact with water \$1.75 s/y 9,350sy
- 2: 2.5" Binder \$86 per ton @ 1,360 tons
- 3: Blending of stone \$.30 s.y@9,350
- 4: Flaggers \$55.00 per hour @ 80 hours

\$140,527.00

Price based on: Liquid Asphalt @\$662.50
1 Mobilization

Not responsible for damage due to vibration
Not responsible for damage to site lighting or irrigation

Terms: Net 30 Days, No Retainage

Busby Construction Co., Inc. reserves the right to charge a 1.5% late fee for all overdue payments.

Busby Construction Co., Inc. reserves the right to charge for attorney fees if needed to collect overdue balances.

Unless a lump sum price is to be paid for the foregoing work and is clearly set forth, it is understood and agreed that prices referred to above are only estimates and that payment shall be made at the stated unit prices on the actual quantities of work performed by the Contractor as determined upon completion of work. Above prices are subject to any applicable taxes.

Any additional work or services, other than those outlined in the "scope of work" above, that become(s) necessary to complete the in-place recycling and/or sub-base preparation will be charged as follows:

Lowbed Rental (portal to portal)	\$ _____ per hour	Dump Truck Rental	\$ 75.00 per hour
Grader Rental (as needed)	\$ 135.00 per hour	Loader / Backhoe Rental	\$ 70.00 per hour
Vibratory Roller Rental	\$ 85.00 per hour	Handwork Grading	\$ _____ per s.y.
Water Truck Rental	\$ 65.00 per hour	Structure Adjustment	\$ _____ per each
Excavator Rental	\$ _____ per hour	Saw cutting	\$ _____ per l.f.

By accepting this proposal, the purchaser acknowledges having read the "Conditions of Sale" on page 2 and further acknowledges having understood same. This proposal may be withdrawn by us if not accepted within 30 days. The above prices, specifications, and conditions are satisfactory and are hereby accepted.

Busby Construction Co., Inc.

Buyer Signature: _____

Authorized Signature: Harold Lafoe

Date: _____

Title: Reclamation Manager



Busby Construction Co., Inc.

9 Pond Lane
Atkinson, NH 03811
P: 603-362-4650
F: 603-362-5051

PROPOSAL

Submitted To: Town of Henniker
Address: 18 Depot Hill Road
City, State, Zip: Henniker, NH 03242
Phone / Fax: 603 428 7200

Date: February 1, 2024
Job Name: Dodge Hill Road
Job Location: Henniker NH
Contact Person: Leo Aucoin

We hereby submit specifications and estimates for the following scope of work:

- 1: Reclaim grade compact with water \$1.75 s/y 9,500sy
- 2: 2.5" Binder \$86 per ton @ 1,375 tons
- 3: Blending of stone \$.30 s.y@9,500
- 4: Flaggers \$55.00 per hour @ 100 hours

\$143,225.00

Price based on: Liquid Asphalt @\$662.50
1 Mobilization

Not responsible for damage due to vibration
Not responsible for damage to site lighting or irrigation

Terms: Net 30 Days, No Retainage

Busby Construction Co., Inc. reserves the right to charge a 1.5% late fee for all overdue payments.

Busby Construction Co., Inc. reserves the right to charge for attorney fees if needed to collect overdue balances.

Unless a lump sum price is to be paid for the foregoing work and is clearly set forth, it is understood and agreed that prices referred to above are only estimates and that payment shall be made at the stated unit prices on the actual quantities of work performed by the Contractor as determined upon completion of work. Above prices are subject to any applicable taxes.

Any additional work or services, other than those outlined in the "scope of work" above, that become(s) necessary to complete the in-place recycling and/or sub-base preparation will be charged as follows:

Lowbed Rental (portal to portal)	\$ _____ per hour	Dump Truck Rental	\$ 75.00 per hour
Grader Rental (as needed)	\$ 135.00 per hour	Loader / Backhoe Rental	\$ 70.00 per hour
Vibratory Roller Rental	\$ 85.00 per hour	Handwork Grading	\$ _____ per s.y.
Water Truck Rental	\$ 65.00 per hour	Structure Adjustment	\$ _____ per each
Excavator Rental	\$ _____ per hour	Saw cutting	\$ _____ per l.f.

By accepting this proposal, the purchaser acknowledges having read the "Conditions of Sale" on page 2 and further acknowledges having understood same. This proposal may be withdrawn by us if not accepted within 30 days. The above prices, specifications, and conditions are satisfactory and are hereby accepted.

Busby Construction Co., Inc.

Buyer Signature: _____

Authorized Signature: Harold Lafoe

Date: _____

Title: Reclamation Manager



Busby Construction Co., Inc.

71 Route 111
Atkinson, NH 03811
P: 603-898-4800
F: 603-898-4808

PROPOSAL

Submitted To: Town of Henniker
Address: 18 Depot Hill Road
City, State, Zip: Henniker, NH 03242
Phone / Fax: 603 428 7200

Date: January 31, 2023
Job Name: Paving 2023
Job Location: Henniker NH
Contact Person: Leo Aucoin

We hereby submit specifications and estimates for the following scope of work:

- 1: Reclaim grade and compact with water @ \$1.75 s/y Blending of stone @ \$.30 s/y
- 2: Binder @ \$77.00 per ton Top @ \$80.00 per ton Hand work @\$165.00 per ton
Capcode berm 6" @ \$13.50 l.f
- 3: Trimming end joints day rate @ \$ 2,250.00
- 4: Shoulder work day rate @ \$ 6,000.00
- 5: Flagging traffic control @ \$50 per hour per flagger

Price based on: **AC @ \$665**

- 1 Mobilization
- Traffic control, dust control, and permits by others
- Not responsible for damage due to vibration
- Not responsible for damage to site lighting or irrigation

Terms: Net 30 Days, No Retainage

Busby Construction Co., Inc. reserves the right to charge a 1.5% late fee for all overdue payments.
Busby Construction Co., Inc. reserves the right to charge for attorney fees if needed to collect overdue balances.

Unless a lump sum price is to be paid for the foregoing work and is clearly set forth, it is understood and agreed that prices referred to above are only estimates and that payment shall be made at the stated unit prices on the actual quantities of work performed by the Contractor as determined upon completion of work. Above prices are subject to any applicable taxes.

Any additional work or services, other than those outlined in the "scope of work" above, that become(s) necessary to complete the in-place recycling and/or sub-base preparation will be charged as follows:

Lowbed Rental (portal to portal)	\$ _____ per hour	Dump Truck Rental	\$ <u>75.00</u> per hour
Grader Rental (as needed)	\$ <u>135.00</u> per hour	Loader / Backhoe Rental	\$ <u>70.00</u> per hour
Vibratory Roller Rental	\$ <u>85.00</u> per hour	Handwork Grading	\$ _____ per s.y.
Water Truck Rental	\$ <u>65.00</u> per hour	Structure Adjustment	\$ _____ per each
Excavator Rental	\$ _____ per hour	Saw cutting	\$ _____ per l.f.

By accepting this proposal, the purchaser acknowledges having read the "Conditions of Sale" on page 2 and further acknowledges having understood same. This proposal may be withdrawn by us if not accepted within 30 days. The above prices, specifications, and conditions are satisfactory and are hereby accepted.

Busby Construction Co., Inc.

Buyer Signature: _____

Authorized Signature: Harold Lafoe

Date: _____

Title: Reclamation Manager



Busby Construction Co., Inc.

9 Pond Lane
Atkinson, NH 03811
P: 603-362-4650
F: 603-362-5051

PROPOSAL

Submitted To: Town of Henniker
Address: 18 Depot Hill Road
City, State, Zip: Henniker, NH 03242
Phone / Fax: 603 428 7200

Date: March 7, 2022
Job Name: Paving 2022
Job Location: Henniker NH
Contact Person: Leo Aucoin

We hereby submit specifications and estimates for the following scope of work:

- 1: Reclaim grade compact with water \$1.60 s/y
- 2: 2.5" Binder \$73.00 per ton
- 3: 1.5" Top \$77.00 per ton
- 4: Flagger \$34.00 per hour
- 5: Berm \$ 14.00 per ton
- 6: Hand work \$ 145 per ton
- 7: Day rate shouldering crew \$6,440.00
- 8: Milling crew \$5.60 s/y

Price based on: Liquid Asphalt @\$650.00

- 1 Mobilization
- Traffic control, dust control, and permits by others
- Not responsible for damage due to vibration
- Not responsible for damage to site lighting or irrigation

Terms: Net 30 Days, No Retainage

Busby Construction Co., Inc. reserves the right to charge a 1.5% late fee for all overdue payments.
Busby Construction Co., Inc. reserves the right to charge for attorney fees if needed to collect overdue balances.

Unless a lump sum price is to be paid for the foregoing work and is clearly set forth, it is understood and agreed that prices referred to above are only estimates and that payment shall be made at the stated unit prices on the actual quantities of work performed by the Contractor as determined upon completion of work. Above prices are subject to any applicable taxes.

Any additional work or services, other than those outlined in the "scope of work" above, that become(s) necessary to complete the in-place recycling and/or sub-base preparation will be charged as follows:

Lowbed Rental (portal to portal)	\$ _____ per hour	Dump Truck Rental	\$ <u>75.00</u> per hour
Grader Rental (as needed)	\$ <u>135.00</u> per hour	Loader / Backhoe Rental	\$ <u>70.00</u> per hour
Vibratory Roller Rental	\$ <u>85.00</u> per hour	Handwork Grading	\$ _____ per s.y.
Water Truck Rental	\$ <u>65.00</u> per hour	Structure Adjustment	\$ _____ per each
Excavator Rental	\$ _____ per hour	Saw cutting	\$ _____ per l.f.

By accepting this proposal, the purchaser acknowledges having read the "Conditions of Sale" on page 2 and further acknowledges having understood same. This proposal may be withdrawn by us if not accepted within 30 days. The above prices, specifications, and conditions are satisfactory and are hereby accepted.

Busby Construction Co., Inc.

Buyer Signature: _____

Authorized Signature: Harold Lafoe

Date: _____

Title: Reclamation Manager

CONDITIONS OF SALE

- 1). This contract sets forth the entire agreement between the parties. There are no other representations or agreements, express or implied, nor conditions concerning the execution and delivery hereof, other than those set forth herein.
- 2). The Contractor shall not be responsible for failure to start or complete work nor for delays in the progress of the work due to causes beyond the Contractor's control, i.e. fire, floods, weather, accidents, strikes, war, or other similar causes. All work to be performed during Contractor's normal operating schedule, unless stated otherwise.
- 3). Any deviations from the specifications, any modifications of the terms of this contract, and any extra or incidental work or reductions, shall be negotiated and the contract prices adjusted accordingly.
- 4). The Contractor shall not be responsible for, and the customer agrees to indemnify and hold the Contractor harmless from any claims or liability resulting in whole or in part, from damages to utilities or other facilities or objects buried beneath the work area, or to sidewalks, driveways, or other improvements located within the work area or designated areas of access.
- 5). It is further agreed that the Contractor shall not be responsible for any damage to or deterioration of any of the Contractor's work, whether completed or in process, resulting from any cause or causes beyond the Contractor's control, such as failure or inadequacy of any labor or materials not furnished and installed by the Contractor, whether or not such failure or inadequacy was or could have been known at the time the Contractor's work was undertaken.
- 6). Unless the Customer owns the property on which the work is to take place, the Customer agrees to submit at the Contractor's request the name and address of the property owner and any other information reasonably necessary for the Contractor to give notices to effect a lien on the property.
- 7). It is understood and agreed the Customer will indemnify and save the Contractor harmless from any and all loss, damage, costs, expenses, and attorney's fees suffered or incurred, in whole or in part, on account of any breach of the obligations and covenants contained in this contract.
- 8). Unless otherwise specified, all permits, fees, lines, grades, stakes, engineering, layout, structure adjustment, traffic control, dust control, reclaiming of debris, removal of excess/unsuitable material, adding of sub-base materials, saw cutting, calcium chloride, sweeping, reclaiming of cobblestone, and trucking are not included in this contract.
- 9). If the customer elects to have the Contractor perform work during adverse weather conditions, such work will be performed at the Customer's sole risk and the Contractor will not guarantee or warranty any of the work performed.
- 10). If fine grading is included in the contract as the primary scope of work, the Customer agrees to provide suitable gravel base, and to rough grade this base within plus/minus one inch of finish base grade. If the Contractor's opinion is that the base is not suitable, any extra fees for needed work to be performed must be agreed upon in writing before work can commence.



TOWN OF HENNIKER, NEW HAMPSHIRE

Town Hall
18 Depot Hill Road
Henniker, NH 03242
Tel: (603) 428-3221

STAFF REPORT

DATE: 2/20/2024

TITLE: Selectmen Schedule for Town/School Election Day March 12

INITIATED BY: Town Clerk

PREPARED BY: Diane Kendall, Town Administrator

PRESENTED BY: Diane Kendall, Town Administrator

AGENDA DESCRIPTION: Sign up for election duties or appoint pro tem

LEGAL AUTHORITY: [RSA 659:9](#); [658:9 and 9-a](#); [658:21](#)

FINANCIAL DETAILS: none

BACKGROUND: Polls are open from 7:00am to 7:00pm

TOWN ADMINISTRATOR COMMENT: N/A

SUGGESTED ACTION or MOTION:

Suggested Action:

Sign up for times to attend or assign pro tem.

Kris Blomback:

Bill Marko:

Scott Osgood:

Neal Martin:

Jeff Morse:



Town Hall
18 Depot Hill Road
Henniker, NH 03242

Tel: (603) 428-3221
Fax: (603) 428-4366

Incorporated November 10, 1768
"Only Henniker on Earth"

TOWN OF HENNIKER, NEW HAMPSHIRE

STAFF REPORT

DATE: 02/20/2024

TITLE: Town Meeting – Warrant Article Presentations, Articles 9-23

INITIATED BY: Helga Winn, Executive Assistant

PREPARED BY: Helga Winn, Executive Assistant

PRESENTED BY: Diane Kendall, Town Administrator

AGENDA DESCRIPTION: The 2024 Town Meeting is scheduled for March 16th at 1:00 p.m. at the Henniker Community School. Chairman will assign motion and speaker for each article to board members.
See attached.

Legal Authority: N/A

Financial Details: N/A

Town Administrator Comment: N/A

Suggested Action/Recommendation:
Suggested Action: Assign members to read and move each article.

TOWN WARRANT

Addendum

2024

Town of Henniker
State of New Hampshire

Town Meeting begins at 1:00 PM
at the Henniker Community School Gymnasium
51 Western Avenue
Saturday, March 16, 2024

To the inhabitants of the Town of Henniker
in the County of Merrimack in the said State
qualified to vote in Town Affairs:

You are hereby notified to meet at the
Henniker Community School Gymnasium in Henniker
on Saturday the Sixteenth (16th) day of March 2024,
at one o'clock (1:00 p.m.) in the afternoon
to act upon the following:

9. To see if the Town will vote to raise and appropriate the sum of \$1,500,000 for the purpose of supplemental upgrades to the wastewater treatment facility, that will qualify the Town for federal and state funds, such sum to be raised by the issuance of serial bonds and notes not to exceed \$1,500,000 under, and in compliance with, the provisions of the Municipal Finance Act (NH RSA 33:1 et seq., as amended) and to authorize the Town officials to issue and negotiate such bonds or notes and determine the rate of interest thereon, and to take such actions as may be necessary to affect the issuance, negotiation, sale and delivery of such bonds or notes as shall be in the best interest of the Town. Additionally, to authorize the Town to apply for and accept grants or other funds that may reduce the amount to be repaid and participate in the State Revolving Fund (SRF) RSA 486.14 established for this purpose, and to allow the Town to expend such monies as become available from the federal and state governments and pass any vote relating thereto. It is anticipated that the Town will receive up to \$425,000 in principal forgiveness from the State Revolving Fund loan program. The remaining bond for this project will be funded by general taxation.

3/5 Ballot Vote Required

Selectmen / Sewer Commissioners Recommend 4-0-1

10. Shall the Town of Henniker vote to raise and appropriate the sum of \$100,000 (One Hundred Thousand Dollars) to hire a Lake Management Consulting Firm to study conditions and provide design solutions to reduce external and internal phosphate loading in French and Keyser Ponds -- to mitigate recurring Cyanobacteria algae blooms in these ponds. And to authorize the issuance of \$100,000 of bonds or notes in compliance with the Municipal Finance Act, RSA 33:1 et seq., as amended, with the amount of such bonds or notes to be reduced by any grant funding received for the project; to authorize the Selectmen to apply for, obtain and accept federal, state or other aid, if any, which may be available for said project and to comply with all laws applicable to said project; to authorize the Selectmen to issue, negotiate, sell and deliver said bonds and notes and to determine the rate of interest thereon and the maturity and other terms thereof; and to authorize the Selectmen to take any other action or to pass any other vote relative thereto. It is anticipated that there will be \$100,000 in principal loan forgiveness under the New Hampshire Department of Environmental Services Clean Water State Revolving Fund(NH CWSRF). Fiscal Impact Note: The tax impact associated with this will be \$0.00 per \$1,000 valuation. The principal loan amount of \$100,000 will be forgiven per the terms of the NH CWSRF agreement. No Tax Impact

3/5 Ballot Vote Required

Selectmen Recommend 4-0-1

SPACE LEFT INTENTIONALLY BLANK

11. To see if the Town will vote to raise and appropriate the sum of Six Million Six Hundred Sixty Thousand Six Hundred Forty-Two Dollars (\$6,660,642) for general municipal operations.

Majority Vote Required

Selectmen Recommend 3-1-1

	2024 Requested	2023 Approved	Difference
EXECUTIVE	355,201	31,686	323,515
TOWN CLERK	107,782	94,275	13,507
ELECTIONS	29,986	6,620	23,366
TAX MAP	4,950	4,950	-
FINANCE	245,518	790,173	(544,655)
TAX COLLECTOR	114,689	94,525	20,164
ASSESSING	55,400	-	55,400
LEGAL	40,000	20,000	20,000
PLANNING	31,726	30,679	1,047
ZONING	5,271	5,271	-
GENERAL GOV'T BLDG	107,758	-	107,758
CEMETERIES	35,030	21,330	13,700
INSURANCE	169,674	156,615	13,059
MUNICIPAL DUES	4,043	4,157	(114)
POLICE	1,487,263	1,435,378	51,885
FIRE & RESCUE	793,503	732,465	61,038
RESCUE	128,997	124,159	4,838
FIRE	175,455	166,347	9,108
CODE	32,388	29,993	2,395
EMERGENCY MGT	5,493	1,292	4,201
HIGHWAY	902,646	861,750	40,896
HIGHWAY & STREETS	874,000	697,500	176,500
STREET LIGHTS	13,500	13,500	-
SOLID WASTE	478,739	584,000	(105,261)
HEALTH	5,883	-	5,883
ANIMAL CONTROL	5,340	9,408	(4,068)
WELFARE	91,702	80,000	11,702
ATHLETIC	32,645	32,645	-
PARKS & PROPERTY	59,249	-	59,249
PATRIOTIC PURPOSES	3,210	3,173	37
CONCERTS	21,726	7,195	14,531
CONSERVATION	2,946	2,890	56
COMMUNITY - CAP PROGRAM	14,000	14,000	-
COMMUNITY - WHITE BIRCH	65,000	65,000	-
DEBT SERVICE - PRINCIPAL	92,596	130,163	(37,567)
DEBT SERVICE - INTEREST	16,265	19,039	(2,774)
DEBT SERVICE - LEASE	37,568	-	37,568
DEBT SERVICE - TAN INTEREST	13,500	13,500	-
Totals	6,660,642	6,283,678	376,964

12. Appropriation to Capital Reserve Funds To see if the Town will vote to raise and appropriate the sum of Four Hundred Seventy Thousand Dollars (\$470,000) to be added to previously established Capital Reserve Funds as follows:

Highway Equipment	200,000
Wastewater	100,000
Fire Equipment	100,000
Bridge Repair	25,000
Transfer Station	30,000
Property Revaluation	15,000
TOTAL	470,000

Majority Vote Required

Selectmen Recommend 4-0-1

13. To see if the Town will vote to raise and appropriate the sum of Eighty Thousand Dollars (\$80,000) to be added to the Ambulance Capital Reserve Fund established in 1988 under the provisions of RSA 35:1 for the purchase of an ambulance for the Rescue Squad, of which the amount of \$10,000 (Ten Thousand dollars) to come from the Town of Bradford. If these funds are not received, the appropriation will be reduced to \$70,000 which will be raised through general taxation.

Majority Vote Required

Selectmen Recommend 4-0-1

14. To see if the Town will vote to raise and appropriate the sum of One Hundred Forty-One Thousand Two Hundred-Two Dollars (\$141,202) for the purchase of a New Rescue Ambulance Chassis and Re-boxing of the 2016 ambulance body and authorize the withdrawal of One Hundred Forty-One Thousand Two Hundred-Two Dollars (\$141,202) from the Ambulance Capital Reserve Fund.

Majority Vote Required

Selectmen Recommend 4-0-1

15. Appropriation to Expendable Trust Funds to see if the Town will vote to raise and appropriate the sum of Eight Hundred Fifty-Five Thousand Dollars (\$855,000) to be added to previously established Expendable Trust Funds as follows:

Road Maintenance	700,000
Police Department Site Purchase, Building Engineering, Design and Construction	100,000
Fire & Rescue Building Maintenance	25,000
Police Department Equipment	10,000
Town Owned Building	10,000
Highway Building Maintenance	5,000
Parks	2,500
Town Technology	2,500
TOTAL	855,000

Majority Vote Required

Selectmen Recommend 4-0-1

16. To see if the Town will vote to raise and appropriate the sum of Three Hundred Five Thousand Dollars (\$305,000) for the purchase of a New Highway Dump/Plow Truck and authorize the withdrawal of Three Hundred Five Thousand Dollars (\$305,000) from the Highway Equipment Capital Reserve Fund established at the 2007 Town Meeting under the provision of RSA 35:1 for the purpose of purchasing highway equipment.

Majority Vote Required **Selectmen Recommend 4-0-1**
17. To see if the Town will vote to raise and appropriate the sum of Twenty thousand dollars (\$20,000) for the purpose of continued restoration of granite and mortar on the exterior of the Tucker Free Library. Furthermore, this appropriation is 100% reimbursable to the Town from a Conservation License Plate Grant Program offered through the State of New Hampshire. If the grant is not received, this article will be null and void.

Majority Vote Required **Selectmen Recommend 4-0-1**
Tucker Free Library Trustees Recommend
18. To see if the Town will vote to raise and appropriate the sum of Two Hundred Sixty-Six Thousand Two Hundred Forty-Four Dollars (\$266,244) for the Tucker Free Library with said amount to be funded by general taxation.

Majority Vote Required **Selectmen Recommend 4-0-1**
Tucker Free Library Trustees Recommend
19. To see if the Town will vote to raise and appropriate the sum of Ten Thousand Dollars (\$10,000) to be added to the Library Accessibility and Safety Project Expendable Trust Fund established at the 2022 Town Meeting under the provisions of RSA 31:19-a, with said amount to be funded by general taxation.

Majority Vote Required **Selectmen Recommend 4-0-1**
Tucker Free Library Trustees Recommend
20. To see if the Town will vote to raise and appropriate the sum of Seven Hundred Eighty Thousand Seven Hundred and Ninety-Two Dollars (\$780,792) for the operating expenses for the Wastewater Treatment Plant with Six Thousand Five Hundred Twenty-Five Dollars (\$6,525) to offset this appropriation by an anticipated water pollution grant and the remainder to be raised by Sewer assessments. No amount to come from general taxation.

Majority Vote Required **Selectmen/Sewer Commissioners Recommend 4-0-1**
21. To see if the Town will vote to raise and appropriate the sum of Five Hundred Fourteen Thousand Six Hundred Sixteen (\$514,616) for the operating expenses of Cogswell Spring Water Works with said funds to come from Water assessments. No amount to come from general taxation.

Majority Vote Required **Water Commissioners Recommend 3-0**
Selectmen Recommend 3-0-2

22. Shall we modify the income and asset limit qualifications for the elderly exemptions from property tax in the Town of Henniker, based on assessed value, for qualified taxpayers. To qualify, the person must have been a New Hampshire residence for at least 3 years, own real estate individually or jointly, or if the real estate is owned by such person's spouse, they must have been married for at least 5 years. In addition, the taxpayer must have a net income of not more than \$70,000 (currently \$48,800), or, if married, a combined net income of less than \$85,000 (currently \$61,000); and own net assets not to exceed \$400,000 (currently \$84,000).

Note: The person's residence equals actual residence and land upon which it is located up to the greater of 2 acres of the minimum single family residential lot size specified in the local zoning ordinances.

Submitted by Petition

23. To see if the Town will vote to eliminate monthly meeting space rental fees paid by an organization whose efforts benefit residents of Henniker.

An organization that raises or contributes cash, items, or public service work hours of \$2,000 per year or more (in value) for the benefit of the Town of Henniker or its residents will not be charged to pay rental fees to the Town for regularly scheduled meeting space (special event space rentals are not covered by this article). This authorization to remain in effect until rescinded by a vote of the Town Meeting. (Majority vote required)

Submitted by Petition

SPACE LEFT INTENTIONALLY BLANK

To transact any other business that may legally come before this meeting. (This article is meant to allocate time that public acknowledgments may be voiced and is not mean to add additional articles to the meeting. The final decision is the responsibility of the Town Moderator (per Henniker Town Counsel).

Given under our hands and seal the 14th day of February 2024

Kris Blomback, Chair

Scott Osgood, Selectman

William Marko, Vice Chair

Jeff Morse, Selectman

Neal Martin, Selectman

CONTINUED BUSINESS



Town Hall
18 Depot Hill Road
Henniker, NH 03242

Tel: (603) 428-3221
Fax: (603) 428-4366

Incorporated November 10, 1768
“Only Henniker on Earth”

TOWN OF HENNIKER, NEW HAMPSHIRE

STAFF REPORT

DATE: 2/20/2024

TITLE: PILOT Agreement – Solar Project, 1104 Old Concord Rd.

INITIATED BY: Andrew Kellar, New Hampshire Solar Gardens

PREPARED BY: Diane Kendall, Town Administrator

PRESENTED BY: Andrew Kellar, New Hampshire Solar Gardens via video connect

AGENDA DESCRIPTION: PILOT Agreement Negotiation

BACKGROUND: **Solar Garden, Andrew Kellar has proposed a revised PILOT Agreement**

HISTORY: The parcel owned by Henniker Holdings, LLC at 1104 Old Concord Road, map/lot 9-549-F2, has a total of 8.93 acres and is improved with a large storage building (former sawmill). The 2023 assessed taxable value is \$468,900 (assessment card attached). The 2022 total taxes for this property were \$10,053 and the first half of the 2023 tax bill is \$5,027. (Both tax bills are attached).

On March 22, 2023, the Henniker Planning Board approved the Conditional Use Permit and the application for a commercial-grade ground-mounted solar array. (Notice of Decision attached). The proposed project involves approximately a 6.2-acre portion of the parcel. The final installed Nameplate Capacity is expected to be approximately 1 megawatt (MW).

The Town’s assessor, Evan Roberge, has analyzed the information provided by Andrew Kellar. Provided the information is correct the estimated assessment range, using the size & number of panels along with an estimated NOI (Net Operating Income) for the 1 MW 6.2-acre project at today’s market conditions is \$1,110,000 to \$1,350,000 (Letter from Assessor attached). The estimated municipal portion of tax revenue at the 2022 municipal rate would yield the following in tax revenue.

Estimated Assessed Value Range:	1,110,000	1,228,500	1,350,000	
	2022 Tax Rate	Estimated Property Tax Range		
Municipal:	6.93	7,692	8,514	9,356
County:	1.79	1,987	2,199	2,417
Local School:	11.84	13,142	14,545	15,984
State School:	0.88	977	1,081	1,188
Totals:	21.44	23,798	26,339	28,944

Legal Authority: [RSA 72:74 – Payment in Lieu of Taxes](#)

Financial Details: New Proposed PILOT payment is \$5,000 per year for a 20-year agreement.

Assessors Comments: There is no known PILOT methodology that was vetted by the state to be the only method used.

The Income Approach to value is used to arrive at the opinion of market value and assessment. This would not be re-assessed annually like PSNH or any other Utility. So once complete and we determine the assessment as of April 1st (again the assessment estimates should be solid based on the information provided), that assessment (barring any improvement/changes) would stay the same until the next town-wide update. The only time it could change in between an update is if the market value of other classifications of property (residential, house, waterfront, etc.) increased at a much greater rate and due to the EQ ratio, needing to adjust commercial or just the solar farm, etc. to put them in line with others to be fair and equitable (this does not typically happen, but worth mentioning just in case).

IRV is not an assessment; it is only a formula to arrive at market value (Income / Cap Rate = Value). If there was no PILOT in place it would be on the MS-1 like any other commercial property, if there does end up being a PILOT in place, it would be under the PILOT section of the MS-1.

There is no way of knowing what the value will be at the next town-wide update, as it will be based on what is generated, being paid per kWh, expenses, at that time etc. and we would request their income and expenses again when that time comes.

Assessor suggests using 72:81 Commercial and Industrial Construction Exemption Statewide as a model for PILOT negotiations.

Town Administrator Comment: N/A

Suggested Action/Recommendation: N/A



PAYMENT IN LIEU OF TAXES AGREEMENT BETWEEN
The Town of Henniker AND Santa Fuel Inc.

This Payment in Lieu of Taxes (PILOT) Agreement (hereafter "Agreement") is made this _____ day of _____ 2024, under New Hampshire Revised Statutes Annotated (NHRSA) § 72:74, between the Town of Henniker, New Hampshire ("Town") and Santa Fuel Inc. ("Taxpayer"), a Connecticut Corporation with a business address at 154 Admiral Street, Bridgeport CT 06605

Background

Taxpayer seeks to develop a renewable solar power electric generating facility (the "Facility") to be located at 1106 Old Concord Road, Henniker NH 03242. Taxpayer expects the final installed Nameplate Capacity to be approximately 1 megawatt (MW/Ac). For the purposes of this Agreement, the term "Nameplate Capacity" shall mean the sum of all of the nameplate capacities for the total solar inverters installed and operating at the Facility. Once the project has reached commercial operation, defined below, the parties will sign a letter amendment to this Agreement specifying the actual Nameplate Capacity of the Facility (if applicable).

The Facility will be built on land leased by Taxpayer, identified on Town tax maps as tax parcels 549-F2

Under its lease agreements with landowners, Taxpayer will be responsible for the payment of local ad valorem real estate taxes on Facility structures and other improvements under NHRSA Chapter 72 (including the taxes on the value of the underlying land as defined by the approved (current or future) planning board site plan).

The Facility will be a "renewable generation facility", as defined in NHRSA §72:73 and NHRSA 374-F:3, V(f)(3). Under NHRSA §72:74, the owner of a renewable generation facility and the governing body of the municipality in which the facility is located may, enter into a voluntary agreement to make payments in lieu of taxes.

Taxpayer and the Town desire to enter into such a PILOT agreement under NHRSA §72:74.

NOW THEREFORE, the parties hereto agree as follows:

Terms and Conditions

1. Payments in Lieu of Taxes. Taxpayer will make payments in lieu of taxes to the Town for each tax year (April 1 to March 31) during the term of this Agreement, in accordance with Sections 3 and 4 below. These PILOT payments will be in lieu of any and all ad valorem real estate taxes otherwise payable under NHRSA Chapter 72, including all town, county, and local school district taxes.

2. Term. Mindful of RSA 72:74, VI and VII, the parties have determined that a long-term agreement providing predictability of tax revenues and expenses would be advantageous to both the Town and Taxpayer. Accordingly, the term of this Agreement shall be 20 (twenty) years as described in Section 4 below. If the Facility fails to achieve commercial operation by February 13, 2027, this Agreement shall be deemed void and of no effect. For the purposes of this Agreement, the term "commercial operation" shall be deemed to have occurred once (a) the solar power electric generating facility has been commissioned and accepted by Taxpayer in accordance with applicable commissioning and inspection procedures (b) the Facility has been interconnected to the utility electric grid, and (c) Taxpayer has commenced the sale of energy from the Facility on a commercial (rather than test) basis to one or more purchasers. The date on which Taxpayer commences energy sales on a commercial basis shall be deemed the "Commercial Operation Date." Taxpayer shall give the Town written notice of said Commercial Operation Date within seven (7) days after it occurs, together with a proposed letter amendment confirming the Facility's actual Nameplate Capacity.

3. PILOT Payments for 20-Year Operating Term. Subject to possible adjustments up or down under Section 4 below, annual PILOT payments to the Town for the 20-year Operating Term shall begin at the rate of \$5,000 per megawatt of Nameplate Capacity, in the tax year that begins on April 1 following the commercial operation date.

If the Facility's actual Commercial Operation Date occurs after March 31, then the schedule of annual PILOT payments during the Operating Term covered by this Section 3 will be amended to reflect that the first year of the Operating Term will be the tax year following the tax year in which commercial operation begins.

4. Potential Adjustment of PILOT Payments.

(a) Increase in Capacity. In the event that some or all of the Facility's increased in the nameplate capacity during the term of the Agreement in such a way as to increase the Facility's total capacity, then PILOT payments beginning in the next tax year will be adjusted upwards.

(b) Reduction in Capacity: If the Facility's installed and operating capacity as of April 1 in any tax year is materially reduced (due to causes beyond Taxpayer's control) from the previous tax year due to: (i) damage caused by natural forces, (ii) operational restrictions caused by a change in law, regulation, ordinance, or industry management standards, (iii) decommissioning and removal of inverters, or (iv) the permanent cessation of the Facility's operations, then the PILOT payment will be adjusted downward based on the total actual installed and operating Nameplate Capacity after the reduction in capacity, or in the case of clause (iv) above, this Agreement will terminate.

5. Payment of Amounts Due. Taxpayer shall make the PILOT payments due hereunder for any given tax year in the Operating Term to the Town in two equal installments, at the Town Tax Collector's office, on July 1st and December 1st.

6. Non-Payment. Non-payment of any payment due the Town shall constitute a default. Notice of non-payment or any other default shall be provided to Taxpayer (and to Taxpayer's Lender, as further specified in Section 7 below), in the manner and at the address provided for Notices in Section 9 of this Agreement. Taxpayer shall have 30 days to cure the default after receiving such notice. In the event the condition causing the default is not cured within 30 days, the Town may commence an action to collect any non-payment under RSA 80:50, seek specific performance of a non-monetary default or proceed against the real estate under RSA 80:58-80. It shall not be a defense to such a proceeding that Taxpayer is obligated under this Agreement to make payments in lieu of taxes rather than taxes.

7. Lender's Right to Cure. The Town shall send a copy of any notice of default sent to Taxpayer to Taxpayer's Lender by certified mail at the same time such notice is sent to Taxpayer, and no such notice of default to Taxpayer shall be effective unless and until a copy of such notice has been delivered to Taxpayer's Lender. Taxpayer's Lender shall have the same time and rights to cure any default as Taxpayer, and the Town shall accept a cure by Taxpayer's Lender as if such cure had been made by Taxpayer. Taxpayer shall provide written notice to the Town as to the name and address of Taxpayer's Lender for such notices to be sent.

8. Other Taxes Not Covered. This Agreement covers only ad valorem real estate taxes payable under NHRSA Chapter 72. It does not include or cover other local, state, or federal taxes which may be payable on account of Facility revenues or activities, including the Land Use Change Tax, Timber Tax, State Utility Property Tax, Business Enterprise Tax, or Federal Income Tax.

9. Notices. Any notice to be provided under this Agreement shall be in writing and shall be deemed to have been given when delivered personally or by certified mail at the following addresses:

For the Town: Town of Henniker, 18 Depot Hill Road, Henniker NH 03242

For Taxpayer: Santa Fuel, Inc., 154 Admiral Street, Bridgeport CT 06605

In the event of a change in the address of any party listed above, the responsible signatory (Taxpayer in the case of itself, its Lender and/or its counsel) shall give the other party prompt written notice of such change of address, which shall be effective upon receipt.

12. Miscellaneous.

(a) This Agreement shall be construed and interpreted in accordance with the laws of the State of New Hampshire. In the event any term of this Agreement or the application of any such term shall be held invalid by any court having jurisdiction, the other terms of this Agreement and their application shall not be affected thereby and shall remain in full force and effect, provided that the remaining terms continue to preserve the essential economic terms of this Agreement.

(b) The terms and provisions contained in this Agreement constitute the final Agreement between the parties with respect to this Agreement and supersede all previous communications, representations or agreements, either verbal or written. No modification or amendment to this Agreement shall be valid unless it is in writing and signed by both parties hereto.

(c) Taxpayer shall have the right, in its sole discretion, to assign this Agreement to any bona fide purchaser, transferee, or assignee, provided that said purchaser, transferee or assignee has the financial, managerial, and technical capacity to construct and operate the Facility as contemplated by the parties hereto. All covenants, agreements, terms and conditions contained in this Agreement shall apply to and be binding upon the parties, their assigns and successors. Taxpayer shall provide written notice to the Town of any sale, transfer, or assignment.

(d) Section titles or subject headings in this Agreement are provided for the purpose of reference and convenience only and are not intended to affect the meaning of the contents or scope of this Agreement.

(e) This Agreement may be executed in multiple counterparts, each of which shall be deemed an original instrument, but all of such counterparts together will constitute but one Agreement.

Town of HENNIKER, NEW HAMPSHIRE

By:
Name:
Date:

Santa Fuel, Inc.

By:
Name:
Date:

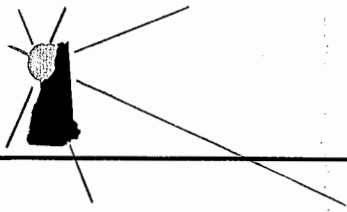

Avitar Associates of New England, Inc.

A Municipal Services Company

July 27, 2023

**Town of Henniker
Helga Winn
Board of Selectmen
18 Depot Hill Road
Henniker, NH 03242**

Re: NH Solar Garden – 1MW Solar Farm Assessment Estimate

Dear Helga & Board Members:

NH Solar Garden is proposing a 1MW Solar Farm consisting of about 2,664 panels. Pursuant to information provided by NH Solar Garden to assist in this assessment estimation, specifically, the nameplate capacity (maximum rated output under specific conditions), Group Net Metering rate (GNM), estimated land lease agreement amount, total estimated cost of the project and estimated annual expenses to operate (including replacement/reserves). This information was used to construct an Income Approach, essentially, doing the math to determine their Potential Gross Income, then subtracting the estimated cost for expenses to arrive at the estimated net operating income (NOI), then once the estimated NOI is known, using a loaded capitalization rate of 11.14% (9% Cap Rate + Taxes) divided into the NOI, indicates a value of the Solar Farm at \$1,228,500 (rounded). The above estimate is for the potential Solar Farm only, and while it is based on information and rates provided, it is only for estimation purposes until the project is complete. The original estimated figure of \$1,336,000, did not included the land lease amount and once that information was provided, the expenses were increased to account for the amount they pay to lease the land the solar farm is situated on, which in turn lowers the Net Operating Income, thus lowering the value of the property. At this point, since we have received all the information needed to have a solid estimation (IRV Formula, $\text{Income/Rate}=\text{Value}$), we feel strongly that the best estimate of where the assessment will be once constructed will be in the low range of \$1,100,000 and high range \$1,350,000. Indicating, using the 2022 Tax Rate of \$21.44, a tax bill range of \$23,600 to \$28,900 (if 100% taxable).

Please know once constructed, the Solar Farm would be on its own PRC (Property Record Card) with the assessment for the Solar Farm only (Under a PILOT or not), the landowner will continue to be assessed/taxed for the residual land; however, their assessment will now include an amount attributed to the land lease.

As always, should you have questions or concerns, please do not hesitate to contact me.

Sincerely,

**Evan Roberge
Assessor Supervisor**

ER/sjc

150 Suncook Valley Highway • Chichester, NH 03258 • (603) 798-4419

www.avitarassociates.com



TOWN OF HENNIKER, NEW HAMPSHIRE

Town Hall
18 Depot Hill Road
Henniker, NH 03242
Tel: (603) 428-3221

STAFF REPORT

DATE: 2/20/2024

TITLE: Comcast Cable Franchise Renewal Agreement – Part 2

INITIATED BY: Diane Kendall, Town Administrator

PREPARED BY: Diane Kendall, Town Administrator

PRESENTED BY: Diane Kendall, Town Administrator

AGENDA DESCRIPTION: Updated information from Comcast regarding the proposed franchise agreement and high-speed internet deployment.

LEGAL AUTHORITY: Federal law ([47 U.S.C. § 521](#), et seq., and the rules of the FCC at 47 C.F.R. Part 76) and state law ([RSA Ch. 53-C](#)). FCC regulations relating to cable franchising are set forth at 47 C.F.R. 76.41 - 76.43. On August 2, 2019, [the Federal Communications Commission \(FCC\)](#) passed an order **that restricts local government cable franchise fees and agreements**. The ruling was published in the Federal Register on August 27 and took effect on September 26, 2019. FCC regulations relating to cable franchising are set forth at 47 C.F.R. 76.41 - 76.43.

FINANCIAL: Legal costs for contract negotiation; potential revenue from Franchise Fees

BACKGROUND: Comcast presented the Board of Selectmen with an early franchise agreement renewal. The current Comcast Franchise Agreement was initially executed in May 1983 through May 2008 and per Section III was extended in 2008 for an additional 25 years expires in 2033. The existing agreement is outdated and not consistent with more recent federal laws.

The governing body is the “franchising authority” to negotiate a renewal agreement with the existing cable tv provider because the cable company will occupy public (town) rights-of-way. Municipalities are entitled to charge the cable company “franchise fees” for that right to occupy public land, just like any other “tenant” of municipal property. **The current franchise fee is \$0.** The town also has a cable franchise agreement with TDS. Both companies shall have similar agreements.

- **The municipality can’t use franchise cable television agreements as an opportunity to regulate parallel broadband services, dictating things like Internet coverage, speed, or prices.**
- The town can negotiate “in-kind” contributions as part of franchise agreements, which cover everything from cable access for low-income areas to planting flowers in public parks.
- The maximum franchise fee is 5% of gross revenue.
- The **gross revenue amount is to be based only on cable television services**, not other services that might also be delivered, such as Internet access, phone, or smart home applications.
- The new ruling requires local governments to count most non-monetary "in-kind" contributions toward the maximum 5% franchise fee.
- Consumers may ultimately bear the burden of extra costs imposed by local municipalities.

As then industry moves towards more broadband-delivered streaming services instead of traditional cable-tv, revenue from cable municipal franchise fees will likely continue to fall and towns charging franchise fees will see decreasing revenues.

Board members and interested public are encouraged to view the recorded [NHMA webinar What Municipal Officials Need to Know about Cable TV Franchising](#). More information: [Cable Franchise Renewal and Local Right of Way Management](#)

TOWN ADMINISTRATOR COMMENT: At the February 6th Selectmen meeting members of the public and the Board asked questions about the current Comcast deployment of high-speed internet. Comcast is currently updating its Henniker infrastructure to deploy high-speed internet that meets the requirements set forth by the Broadband Committee. A construction update with estimated timeline is provided with this report and posted to the Broadband Committee page on the town website.

- Broadband is an information service and not subject to local regulations.
- Comcast will deploy Fiber to the node (FTTN) then coax. According to www.technopedia.com “Fiber to the node helps to provide broadband connection and other data services through a common network box, which is often called a node. Fiber to the node may also be called fiber to the neighborhood.”
- Comcast is deploying the infrastructure for up to 673 passings (110 of them are at a campground). They have been adding to our list as they build.

TA recommend the board convene a Henniker Cable TV Committee to negotiate the agreement and make recommendations to the Board of Selectmen. The Broadband Committee has completed its charge. Some members may be willing to serve on the Cable TV Committee. Keep it small, 3 to 5 members.

Survey of Franchise Fees in other communities:

Franchise Fees				
Peterborough	1.5%			
Jaffrey	5%			
New Ipswich	3%	100% to video committee		
Lyndeborough	0%			
Hopkinton	0%			
Francestown	3%			
Deering	4%			

SUGGESTED ACTION OR MOTION:

Motion to convene an ad-hoc Cable TV Committee (3 members) with charge to:

- ***Review current and proposed agreement with Comcast and TDS***
- ***Ascertain future cable-related needs and interests of the community.***
- ***Negotiate the agreement with or without franchise fees and “in-kind” contributions.***
- ***Make recommendations to the Board of Selectmen.***
- ***Discharge committee when mission is complete.***

2023 Henniker Broadband ~ Town of Henniker Annual Report

The Henniker Broadband Committee has been meeting under the direction of Carol Miller, Director of Broadband Initiatives, the National Collaborative for Digital Equity. The Committee goals were to improve access to high-speed, affordable, reliable, and future ready broadband for all in town.

The Henniker Broadband Committee was established on November 3, 2022, because of a growing concern of resident taxpayers with regards to access to internet services. Town Administrator Dianne Kendall recruited members of the community to serve on the committee that were interested in investigating and analyzing the availability and high-speed capacity of current broadband service. The Committee attended monthly meetings (12) held on the 1st Wednesday of the month and stepped through a process of gathering information and interviewing internet service providers who were in a position to improve service capacity and options while filling gaps of adequate coverage in areas of town with poor performing internet access and low-speed broadband.

The committee is made of the following members: Marc McMurphy, Chair, Paul Knudsen, Jesse Pinnell, Robert Pagano, Scott Osgood, Carol Conforti-Adams and Diane Kendall.

The committee has identified all residences in Henniker that do not have access to high-speed broadband. The committee also communicated the town's desire for those locations to have access to providers already providing service in Henniker. After interviews with existing providers, seeing their plans, and hearing verbal commitments to extend high-speed broadband to the remaining unserved residences in a reasonable amount of time, the committee feels that no further action is required at this time.

We are pleased with the outcome of our work and minutes of our meetings and a final report are available on the town website at <https://www.henniker.org/henniker-broadband-committee>. We look forward and feel confident that Henniker residents and businesses have access to the broadband capacity to take advantage of economic opportunity, and access to health care, government services, and educational advancement.

Sincerely,

Marc McMurphy

Chair—Henniker Broadband Committee

Comcast General Construction Overview

February 8, 2024

If a Street is listed with an estimated launch date and the street(s) under it do not have an estimated launch date, they are grouped in with the Street(s) above them.

Street	Estimated Release	# of Passings
Bear Hill Rd	6/14/24	30
Peasley Rd		7
Western Ave	6/14/24	19
Cote Hill Rd		13
Patterson Hill Rd	7/19/24	2
Quaker St		4
Bear Hill Rd		1
Faulker Rd		2
Ryan Rd		1
Huntington Rd		7
Peasley Rd	7/19/24	2
Lyman Rd		1
Matthews Rd		4
Baker Rd		4
Butter Rd	8/16/24	8
Gulf Rd		13
Quaker St	8/16/24	12
Dudley Pond Rd		1
Craney Hill Rd	9/20/24	11
Flanders Rd		32
Stonehenge Dr		8
Craney Pond Rd		7
Chase Rd		2
Snowshoe Rd		10
Mt Hunger Rd	9/20/24	18
Morse Rd		3
Keyser Pond Campground	10/18/24	110
Old West Hopkinton Rd	10/18/24	1
Dodge Hill Rd	10/18/24	9
French Rd		13
French Pond Rd		13
Eastside Dr		2
Depot Hill Rd	10/18/24	4
Locust Ln		4
Freeman Colby Rd	10/18/24	6
Old Hillsboro Rd		3
White Birch Ln	10/18/24	6
Craney Hill Rd		25
Craney Pond Rd		2
Tower Rd		2
Corbin Rd		6
Old Hay Rd		2

Comcast General Construction Overview

February 8, 2024

If a Street is listed with an estimated launch date and the street(s) under it do not have an estimated launch date, they are grouped in with the Street(s) above them.

Street	Estimated Release	# of Passings
245 Flanders Rd - Pvt Trench	10/18/24	1
Colby Crossing Rd	11/15/24	7
Weare Rd		8
Rte 114		6
Ruffled Rd		17
Patch Rd	11/15/24	15
Quarry Hill Ct		4
Weare Rd		6
Bound Tree Rd	12/13/24	2
Dodge Hill Rd		5
Echo Ln		3
Hemlock Cir		3
Hemlock Corner Loop		5
Ray Rd		70
Goodwin Rd	12/13/24	2
Patch Rd		1
River Rd		1
Weare Rd		3
Bennett Rd		6
Elm St		9
Weare Rd / Rte 114		3
Temple Rd		2
Liberty Hill Rd	1/17/25	5
Colby Hill Rd	1/17/25	3
Emery Rd		1
Rand Rd		2
Whitney Rd		2
Dodge Hill Rd	1/17/25	2
French Rd		3
Line Hill Rd		1
Lone Pine Rd		3
Robertson Rd		2
Browns Way	1/17/25	1
Western Ave		15
Colleague Pond Rd	1/17/25	5
Hemlock Corner Loop		13
Cross Rd		4
Warner Rd		2

August 24, 2023

Ms. Diane Kendall
Town Administrator
Town Hall
18 Depot Hill Road
Henniker, NH 03242

RE: Comcast Response to Town of Henniker Request for Proposal Broadband Improvement Implementation

Dear Ms. Kendall:

Comcast Cable Communications, LLC (“Comcast”¹) has reviewed the Request for Proposals for Improvement of Broadband Services (the “RFP”) issued by the Town of Henniker (the “Town”) with respect to deploying broadband infrastructure to unserved locations identified in the RFP. Comcast is pleased to inform the Town that its ongoing network investments within the Town will include broadband serviceable locations as provided through the RFP. After further analysis and review of the locations, Comcast was able to identify 106 unserved locations that will be included in its current broadband deployment project. Comcast plans to submit pole permit applications within the next two weeks. The locations will be serviceable within 6-12 months, pending there are no make-ready delays, thus, achieving near universal broadband coverage in the Town.

Comcast is committed to investing in the communities in which we live and serve. Comcast has served Town residents and businesses for over 20 years, providing them with state-of-the-art broadband service. As previously discussed with Town officials, our current broadband deployment project is extending infrastructure to 246 locations within the Town. This project will continue without seeking a contribution from the Town or its residents and includes broadband serviceable locations identified in the RFP. The locations in the RFP have become more economical to build because our current broadband deployment project will extend our infrastructure closer to other unserved locations within the Town. Additionally, the availability of our construction contractors allows us to complete the unserved locations in a timely manner.

¹ **Note:** Comcast Cable Communications, LLC is a wholly owned indirect subsidiary of Comcast Corporation. Comcast Corporation is a publicly traded company that through its cable division subsidiaries, including, but not limited to Comcast Cable Communications, LLC, provides cable television, voice and internet services. For the purposes of this response, the term “Comcast” throughout this response may refer to Comcast Corporation, Comcast Cable Communications, LLC, or the Comcast Corporation cable division operating Comcast subsidiaries or affiliates holding cable television franchises in the relevant jurisdictions. In the event of a grant award, for the avoidance of any doubt, the contracting entity for Comcast will be Comcast Cable Communications, LLC and all grant obligations binding upon Comcast Cable Communications, LLC must be agreed to in a separate writing between the parties.

For a brief overview of Comcast network performance and ongoing investments that directly impact the Town of Henniker and its residents, please find below the highlights of our network capacity, resiliency, and scalability; services provided; and broadband adoption efforts.

Comcast's Network Performance and Ongoing Investments

Over the past three years, Comcast has invested nearly \$278 million in private, at-risk capital in New Hampshire, building, maintaining, and operating one of the most extensive fiber-based networks in the country. This investment enables Comcast to stay ahead of consumer demand, which was especially important in 2020 when Internet traffic spiked more than 30% as people transitioned to working and learning from home, and our network continued to deliver fast speeds, even under the heaviest usage.

In addition to an all-fiber backbone that connects communities coast-to-coast, Comcast has consistently added and expanded fiber throughout the portion of its network that serves customers directly (called the "access" network). Comcast has extended its fiber network closer to customers' homes, including numerous fiber-to-the-home ("FTTH") and fiber-to-the-premise ("FTTP") deployments delivering Comcast's full range of services to both commercial and residential customers. Comcast's fiber network is continuously monitored and protected by proprietary, internally developed artificial intelligence ("AI") and machine learning technologies that can automatically detect issues like fiber tears, and dramatically reduce the estimated time to repair. In a world where fiber cuts and tears are a daily experience across the country, smart AI that detects and mitigates such incidents can mean the difference between customers being offline for a few minutes or several hours.

Comcast's significant ongoing network and technology investments enable us to continually deliver innovative products and services that keep residents and businesses on the cutting edge. In fact, we are currently rolling out the nation's largest and fastest multi-gig network deployment, reaching more than 50 million homes and business before end of 2025. The Xfinity 10G Network is next-generation broadband for our residential customers and provides a combination of reliability, security, power, resilience and innovation, and will provide even faster multi-gig symmetrical speeds.

For additional information on Comcast's Network Performance, please see Comcast's Network Performance Report at https://update.comcast.com/wp-content/uploads/sites/33/dlm_uploads/2022/02/0222_2021NetworkReport_V19.pdf

Xfinity 10G Network - Background

Recently, Comcast announced its launch of even faster, 10G-enabled multi-gig symmetrical speeds that begin this year. In addition to the immediate performance boost, this work also accelerates the transition to DOCSIS 4.0 and 10G. 10G is a technology platform that Comcast is using to digitize and virtualize much of the physical device technology and to move many of those activities into the cloud, allowing Comcast to innovate at the speed of software and to

deliver multigigabit upload and download speeds to tens millions of Americans over the connections they already have in their homes.

Comcast has been deploying similar technologies for years as part of this evolution – in the industry it is known as Distributed Access Architecture (DAA) and “virtualized” Cable Modem Termination Systems (vCMTS). By leveraging full duplex and extended spectrum capabilities, Comcast will be able to deliver those multi-gigabit speeds over its existing hybrid fiber coaxial network. In preparation for faster network speeds, earlier this year, Comcast launched its latest Wi-Fi 6E Gateway, one of the first in the world to support multi-gigabit symmetrical Wi-Fi.

Because Comcast is evolving its entire network architecture, equipment, and customer devices, we are uniquely positioned to deliver these advancements in speed, reliability, and performance to everyone we serve, not just a select few. And because much of this work is powered by software, these changes can be made with far less disruption to customers than other technologies. For more information on Comcast’s multi-gig network deployment, see <https://corporate.comcast.com/press/releases/comcast-expand-evolve-wifi-largest-multi-gigabit-network>.

Xfinity 10G Network - Customer Impact

Comcast’s next-generation network and Internet experience are powering homes today and into the future:

- **Ultimate Capacity:** Xfinity customers connect nearly 1 billion devices across the Company’s network annually. The Xfinity 10G Network with the next-generation Xfinity gateways deliver the most advanced WiFi technology carrying three times more bandwidth to power streaming, gaming, videoconferencing, and more, simultaneously.
- **Fastest Internet:** Approximately one third of Xfinity Internet customers subscribe to gigabit speed products, and Ookla rated Xfinity the fastest Internet provider at the end of 2022*. Symmetrical gig speeds to the first homes are planned for later this year.
- **Unprecedented Coverage:** The latest Xfinity Gateway provides a more reliable connection throughout the home. Customers can get wall-to-wall WiFi coverage with a powerful xFi Pod that extends coverage to hard-to-reach areas, with plans for an offering of increased support for in-home WiFi through a “boost guarantee” later this year.
- **Most Reliable Connection:** Comcast is scaling the nation’s largest and most reliable network – the Xfinity 10G Network – that passes 61 million homes and business and counting. The Company plans to launch a new device that is “storm-ready” with cellular and battery backup to help keep customers connected even when the power goes out.
- **Ultra-Low Latency:** The Xfinity 10G Network and the latest xFi Gateway are a powerful combination that deliver ultra-low latency for those moments when response times matter most like video games, a fast-growing category with Xfinity households averaging more than one gaming console per home.

For more information, visit <https://www.xfinity.com/10G>.

Xfinity Services

Comcast offers customers multiple choices of residential and commercial broadband services, depending on the customers' specific needs. Attachment A to this letter outlines the service tiers, speeds and pricing currently available in the Town, and is provided for informational purposes only. We have also introduced xFi, the ultimate in-home WiFi experience powered by our xFi Gateway. xFi features in the Xfinity app enable customers with an xFi Gateway to monitor, control and pause their network and devices, giving them total control over all their devices, all in one place. In addition to our Xfinity Internet service, Comcast also offers a full suite of products and services, including voice, video, mobile and home security services. For more information on these services, please visit www.Comcast.com.

Broadband Adoption Efforts – Comcast Internet Essentials and ACP

Comcast has long been committed to addressing the broadband adoption issue through [Comcast Internet Essentials](#), the most comprehensive and successful low-income broadband adoption program in the nation. Since its introduction in 2011, Internet Essentials has connected 64,000 low-income New Hampshire residents in 16,000 homes. The program provides qualifying households with broadband service at speeds of up to 50 Mbps/10 Mbps for \$9.95 a month or speeds of up to 100Mbps/20Mbps for \$29.95/month as well as free digital skills training in person and online. Customers have the option to purchase a low-cost Internet-ready computer.

Comcast is also proud to be a participating provider in the federal government's Affordable Connectivity Program ("ACP"). Under ACP, qualifying households may receive a credit of up to \$30/month (\$75/month in Tribal lands) toward any Xfinity Internet service tier, including Internet Essentials and Internet Essentials Plus, and/or Xfinity Mobile service. If customers have both Xfinity Internet and Xfinity Mobile, the ACP credit will first be applied toward Internet and any remaining credit will be automatically applied to their Xfinity Mobile data usage and/or services fees.

As of August 21, 2023, ACP has helped to connect more than 20 million households to broadband access. At a May 2022 White House event, Comcast was recognized for stepping up with innovative offerings like Internet Essentials Plus to help eligible households take full advantage of the ACP credit.

Internet Essentials and Internet Essentials Plus are each fully covered by the ACP credit. In addition, an Internet Essentials customer (paying \$9.95/month) who is enrolled in ACP can have the remaining ACP credit applied to their Xfinity Mobile service. For example, an Internet Essentials participant (paying \$9.95/month) who adds one line of Unlimited on Xfinity Mobile (\$45/month) will only pay \$24.95/month after applying the remainder of the ACP credit. For more information, see <https://corporate.comcast.com/press/releases/comcast-affordable-connectivity-program-internet-essentials-service-xfinity-mobile>.

Comcast's outreach efforts to increase ACP awareness and participation include leveraging numerous marketing channels (such as radio, TV, print, social media, in-person events and online ads) to reach eligible households. Furthermore, the Company works closely with government officials and our community partners to bring awareness to the community. These partners include the Falmouth Public Schools, the Falmouth Housing Authority, and the Falmouth Senior Center.

I hope this information is useful in providing an overview of the power, speed and resiliency of Comcast's network, as well as our broadband adoption efforts. As you can see, Comcast is well positioned to meet the needs of residents and businesses in the Town now and into the future.

Please contact me at bryan_christiansen@comcast.com or 617-279-6956 if you would like to set up a meeting or if you have any questions related to the contents of this letter or our current network investments in the Town.

Sincerely,

A handwritten signature in black ink that reads "Bryan Christiansen". The signature is written in a cursive style with a long horizontal flourish extending to the right.

Bryan Christiansen
Director, Government & Regulatory Affairs
Comcast Greater Boston Region

C.c Monica Thibault, Comcast Manager of Government & Regulatory Affairs

PAST MEETING MINUTES

DRAFT

Disclaimer – The following are Draft Minutes, which could include errors and are subject to change upon approval of the Select Board.



**Town of Henniker
Board of Selectmen Meeting
Tuesday February 6, 2024 6:15 PM
Henniker Community Center**

Members Present: Selectman Neal Martin, Selectman Jeff Morse, Selectman Scott Osgood
Member’s Excused: Chairman Kris Blomback, Vice-Chairman Bill Marko,
Town Administrator: Diane Kendall
Recording Secretary: Hank Bernstein
Guests: See attached Sign-In Sheet

CALL TO ORDER/PLEDGE OF ALLEGIANCE

Item #1 - Nominate meeting chairman in absence of Chairman and Vice-Chairman

Selectman Osgood moved to Nominate Selectman Neal Martin to be Acting Chairman for this meeting, seconded by Selectman Morse. The motion passed, unanimously.

ANNOUNCEMENTS

- Hearings for the 2024 Budgets, Warrant Articles and Borrowing will be held on February 13, 2024, at 6:30pm at the Community Center.
- The Board of Selectmen and Fire/Rescue Chiefs announce the resignation of Will Amos, full-time Firefighter/Paramedic. Will has been an asset to the department in his current position. We wish him well in his future endeavors.
- Best wishes to Jim Donison, Cogswell Water Department Superintendent as he is traveling to Washington, DC for the Rural Water Rally Great American Water Taste Test on Wednesday February 7th!
- Water Main Repair on Friday February 16, 2024, residents on Hall Ave will be without water between the hours of 8:00 a.m. and 5:00 p.m. The shutdown will impact properties on Hall Ave only between Prospect Street and Post Office Place.
- Please remember to sign up for Alerts and Notification on the town website www.henniker.org.

CONSENT AGENDA

Item #2 - Selectman Osgood motioned to approve the Consent Agenda February 6, 2024, seconded by Selectman Morse. The motion passed, unanimously.

APPOINTMENTS WITH THE BOARD

Item #3 - Monica Thibault, Manager, Comcast Government Relations and Bryan Christiansen, Comcast Director of Government & Regulatory Affairs

Ms. Thibault and Mr. Christiansen explained the current cable TV franchise agreement with the town was initially executed in 1983 and auto renewed and automatically renewed for 25 years in 2008. Comcast is seeking early renewal to update the agreement to be consistent with Federal Communications Commission (FCC) rules. The governing body (Board of Selectmen) is the “franchising authority” to negotiate a renewal agreement with the existing cable TV provider because the cable company will occupy public (town) rights-of-way. Municipalities are entitled to charge the company “franchise fees” for that right to occupy public land, just like any other “tenant” of municipal property. The current franchise fee is \$0. This is known as an Informal Process under the law which provides that renewal can be requested by a cable operator at any time. Cable TV providers may only be denied

DRAFT

Disclaimer – The following are Draft Minutes, which could include errors and are subject to change upon approval of the Select Board.

renewal of their franchises in a community once initially granted if they are in default of their current franchise agreements or their proposals are not “reasonable.” Additionally, if the municipality has a Franchise Agreement with another cable TV company, the town shall provide a similar agreement. The town also has a cable franchise agreement with TDS. Discussion and questions ensued. **Acting Chair Martin moved to research the item further, seconded by Selectman Morse. The motion passed unanimously.**

PUBLIC COMMENT #1

Susan Adams, of Ramsdell Rd, asked if there had been updates to the Ramsdell Rd request for action regarding speed and traffic on the road. TA Kendall shared that the Highway Safety Committee was directed by the Board of Selectmen to convene on the subject. A meeting date has not been set. Ms. Adams and others will be contacted, and notices will be posted on the website and bulletin board.

CONTINUED BUSINESS

Item #4 - ARPA Funds

a. Electronic Sign

Highway Superintendent Leo Aucoin solicited three quotes for the electronic sign. Aucoin recommended the low quote from Work-Safe and commented the department rents a similar sign from Work-Safe. Supt. Aucoin noted that this sign will be useful for multiple departments. Discussion ensued and Aucoin answered questions from the board regarding specifications. **Selectman Morse moved to waive Purchasing Policy Exception to Bid Process #16 as strict adherence to the sealed bid process is not in the best interest of the town, seconded by Selectman Osgood. Motion carried unanimously.**

Selectman Morse moved to accept the quote from Work-Safe and to expend \$19,930 of remaining local ARPA funds for the purpose of purchasing an electronic sign board made by Ver-Mac model PCMS 548, seconded by Selectman Osgood. Motion carried unanimously.

b. Azalea Park

Susan Adams, of the Azalea Park Committee, provided an update to the original request for ARPA funds for Azalea Park walkway stabilization. The committee presented a quote for design and permitting service related to stabilizing a section of bank at Azalea Park for \$40,641. Ms. Adams said the committee is still requesting at least \$75,000 in ARPA funds for the project. Discussion ensued. The Selectboard will reconsider at another meeting of the full board. No motions were made.

APPOINTMENTS WITH THE BOARD

Conservation Commission Warrant Article

Mark Mitch, Co-Chair the Conservation Commission, shared that commission has submitted a warrant article for the next steps in addressing the cyanobacteria blooms. This warrant article is for a loan through the Department of Environmental Services and is 100% forgivable. No taxpayer funds will be raised from the town for the project and will be completed within the year. The hearing for the warrant article is posted for Tuesday February 13th.

CONTINUED BUSINESS

Item #5 - Town Meeting Location and Production

TA Kendall said Henniker Community School (HCS) could provide annual Town Meeting support for audio/visual operations for minimal cost; After attending an event at the Putnam Center, Supervisor of the Checklist Lori Marko and Selectman Marko expressed preference for HCS. TA Kendall expressed gratitude that New England College gave the opportunity to use their facility and recommended

DRAFT

Disclaimer – The following are Draft Minutes, which could include errors and are subject to change upon approval of the Select Board.

holding Town Meeting at HCS. **Selectman Morse moved to hold Town Meeting at HCS, seconded by Acting Chair Martin. Motion carried unanimously.**

Item #6 - Budget

TA Kendall shared the changes to the 2024 draft budget since the last presentation. Reports provided to the board.

NEW BUSINESS

Item #7 - Hazard Mitigation Update and Committee Appointment

TA Kendall shared that it is time to update the Hazard Mitigation Plan (HMP). There is no cost to the town, and it is funded by Homeland Security. This HMP is important to remain eligible for FEMA funding.

Acting Chair Martin moved to authorize the Central New Hampshire Regional Planning Commission Letter of Agreement for the Henniker HMP Update 2025 by signature, seconded by Selectman Morse. Motion carried unanimously.

Selectman Morse moved to appoint Selectman Neal Martin to the HMP Committee, seconded by Selectman Osgood. Motion carried unanimously. Acting Chair Martin asked that this vote be ratified at the next meeting.

Selectman Morse moved to appoint the following Municipal Appointee positions to the HMP Committee and appoint a volunteer member representative from each of the following committees; committees to notify the Town Administrator of member name and contact information. Acting Chair Martin seconded the motion. Motion carried Unanimously.

Municipal Appointee	Member
Emergency Management Director	Stefanie Costello
Town Administrator	Diane Kendall
Fire Chief or Designee	Jim Morse
Police Chief or Designee	Matt French
Health Officer	Greg Aucoin
Building Inspector/Code Enforcement	Bob Garside
Highway Dept Road Agent or Designee	Leo Aucoin
Transfer Station Manager or Designee	Marc Boisvert

Committees
Energy Committee
Conservation Commission
Athletic Committee
Planning Board
Economic Development Committee

Item #8 - Accept [2022 Audited Financial Statements](#)

Acting Chair Martin moved to accept the 2022 Independent Audit and Financial Statements, seconded by Selectman Morse. Motion carried unanimously.

PAST MEETING MINUTES

Item #9 - Board of Selectmen Meeting Minutes January 16, 2024, 6:15pm

Acting Chair Martin moved to accept these minutes, seconded by Selectman Morse. Motion carried unanimously.

COMMUNICATIONS

Item #10 - Town Administrator Report

TA Kendall reported on:

- Working with the Fire and Police Chiefs on wage budgets.
- February 20th the Board of Selectmen will have a public hearing for changes to fees related to Police, Fire, and Rescue details.
- PSNH appeals.

DRAFT

Disclaimer – The following are Draft Minutes, which could include errors and are subject to change upon approval of the Select Board.

- Challenges associated with NEC Student and Faculty parking.
- Clean up in the Community Center closet.
- Comcast Cable TV Franchise Agreement.

Item #11 - Correspondence

None

Item #12 - Selectmen Reports

Selectman Martin had nothing to report.

Selectman Morse had nothing to report

Selectman Osgood reported on an event he attended.

PUBLIC COMMENT #2

Ruth Zax, of Hall Ave, asked about grant opportunities for the Azalea Park Committee, and asked about existing trust funds for Azalea Park. TA Kendall noted that the Trustees of the Trust Funds would be the group to reach out to on that matter.

ADJOURNMENT

Selectman Morse motioned to adjourn at 7:52 PM, seconded by Selectman Osgood. The motion passed, unanimously.

Respectfully submitted,

Hank Bernstein
Minute Taker

Minutes Approved:



Meeting: BOARD OF SELECTMEN

Date: February 6, 2024

PLEASE PRINT

Name

Address

SUEAN ADAMS

32 Ramsdell Rd

Joan O'Connor

7 Echo Lane

Ruth Zax

247 Hall Ave

Alison Miroho

10 Ramsdell Rd

Marie Mitch

Henniker

DRAFT

Disclaimer – The following are Draft Minutes, which could include errors and are subject to change upon approval of the Select Board.



**Town of Henniker
Board of Selectmen Meeting
Tuesday February 9, 2024 5:00 PM
Henniker Town Hall**

Members Present: Chairman Kris Blomback, Neal Martin, Scott Osgood
Member’s Excused: Vice-Chairman Bill Marko, Jeff Morse
Town Administrator: Diane Kendall
Others Present: Jim Morse, Fire Chief; Rescue Chief Greg Aucoin
Recording Secretary: Diane Kendall

CALL TO ORDER

Chairman Blomback called the meeting to order at 5:00pm

NEW BUSINESS

At 5:01pm Chairman Blomback motioned to enter non-public session citing RSA 91-A:3, II(b) The hiring of any person as a public employee, seconded by Selectman Martin. Roll call vote Blomback, yes; Martin, yes; Osgood, yes.

The board entered non-public session at 5:01pm.

The public session reconvened at 5:40pm.

Selectman Osgood motioned to seal the minutes because it is determined that divulgence of this information likely would render a proposed action ineffective, seconded by Selectman Martin. Roll call vote Blomback, yes; Martin, yes; Osgood, yes.

ADJOURNMENT

Selectman Martin motioned to adjourn at 5:41PM, seconded by Selectman Osgood and passed, unanimously.

Respectfully submitted,

Diane Kendall
Minute Taker

Minutes Approved:



**Town of Henniker
Board of Selectmen/Wastwater Commissioners 2024 Budget and
Warrant Articles Public Hearing
Tuesday February 13, 2024 6:30 PM
Henniker Community Center**

- Members Present:** Chairman Kris Blomback, Vice-Chairman Bill Marko, Selectman Jeff Morse, Selectman Scott Osgood
- Member's Excused:** Selectman Neal Martin
- Town Administrator:** Diane Kendall
- Finance Director:** Sherry Bradstreet
- Recording Secretary:** Hank Bernstein
- Department Heads:** Greg Aucoin, Rescue Chief; Debbie Aucoin, Tax Collector/Town Clerk; Leo Aucoin, Highway Superintendent; Marc Boisvert, Solid Waste/Buildings Grounds/Parks and Properties Superintendent; Lynn M. Piotrowicz, Tucker Free Library Director; Richard Slager, Wastewater Superintendent.
- Guests:** David J. Mercier, P.E. (NH,VT) Vice President Underwood Engineers, Inc.
Marc Mitch, Conservation Commission Co-Chair
Joe Petrick, Tucker Free Library Trustee
See attached Sign-In Sheet

CALL TO ORDER/PLEDGE OF ALLEGIANCE

Chairman Kris Blomback opened the meeting with recitation of the Pledge of Allegiance and called the meeting to order at 6:30pm.

ANNOUNCEMENTS

Chairman Blomback gave background on the municipal budgeting process and summary of the 2024 budget.

- The general fund operating budget request is \$6,926,886 which is an expenditure increase of \$ 400,998 or 6.14% over \$6,525,888 in 2023. Since \$130,000 of the operating budget increase is 100% offset by highway block grant revenue, the net general fund operating increase is \$ 270,998 or 4.15% over 2023.
- General fund operating revenue is estimated to be \$2,897,544, an increase of \$382,617 or 15% over \$2,514,927 estimated 2023. If we exclude the \$130,000 in offsetting revenue from the Highway Block grant, the net increase to revenue is \$252,617 or 10%.
- The estimated net to be raised by taxation for general fund operating expenditures is \$4,029,342 increase of \$18,381 or .5% over \$4,010,961 estimated in 2023.
- The valuation used for the town tax rate in 2023 was \$737,302,447. 2024 values will be reported as of April 1, 2024. We can estimate that \$737,302 of appropriation or the same in non-tax revenue will impact the tax rate by \$1.00; \$73,730 will impact the tax rate by .10 cents; \$7,373 will impact the tax rate by .01 cent.
- The annual tax rate is set in the fall of the current budget year, after towns, schools and counties have submitted annual budgets, prior year audited financial statements, and revised revenue estimates. The 2023 town rate per \$1,000 of assessed value was \$6.93. To estimate the 2024 town portion of the tax rate we use the 2023 valuation of \$737,302,447 divided by the estimated 2024 net amount to be raised \$5,546,342 to arrive at \$7.52.
- The Board of Selectmen adopted a Fund Balance Policy that may appropriate any amount of the UFB more than the designated percentage minimum of 6% and maximum of 10% to offset property taxes as part of the final adopted budget for the fiscal year. In addition, excess funds may be used, upon town meeting approval, for capital improvement projects, equipment replacement and other similar budgetary needs. The current unassigned fund balance is \$1,718,373 or 8.67% of general fund expenses. Retaining a minimum UFB of 6%

DRAFT

Disclaimer – The following are Draft Minutes, which could include errors and are subject to change upon approval of the Select Board.

would allow a maximum \$529,771 to be used upon town meeting approval. We recommend the use of excess current UFB in the amount of \$400,000 to offset the operating budget. Additional fund balance may be used to offset tax rate in the fall in the tax rate setting period, after 2023 audited financial statements are available.

- Based on the town's Personnel Policy, regular employees are entitled to 0% to 4% merit adjustments effective the first pay period in April. For budgeting purposes based on incoming performance rating scores, an average merit adjustment of 3.5% has been applied to 2023 wage data. The Board of Selectmen agreed to a draft budget to include a 2% COLA adjustment to 2023 wage data. Wages, stipends, payroll taxes, insurances, and retirement benefits combine to the amount of \$3,979,033 and account for about 57% of the general fund operating budget. The total is increase \$120,998 \$3,858,035 in 2023.
- The town provides health/dental/life and disability insurance benefits to eligible full-time employees. The guaranteed maximum rates (GMR) for the July 1, 2024, renewal is a 14% increase. The configuration of employees with family plans to individuals and opt-opts has changed offsetting the impact of the premium rate increase. Dental rates are also cost shared at approximately 50% and have a GMR of 4.7%.
- Other items included in the budget increases include property liability insurance, energy costs, technology services, legal services, welfare applications, and costs of materials and equipment for road maintenance, level of service increases.

2024 HEARING WARRANT ARTICLE #3 FOR WASTEWATER BOND/NOTE

- Board of Selectmen/Wastewater Commissioner Chairman Blomback opened the public hearing.
- TA Kendall explained the warrant article is to borrow \$1,500,000 for the purpose of supplemental upgrades to the wastewater treatment facility. It is anticipated that the Town will receive up to \$425,000 in principal forgiveness from the State Revolving Fund loan program.
- David Mercier, VP Underwood Engineers provide the board history, summary of the current upgrade and scope of work for the supplemental funds covered under the bond/note funding request.
- Chairman Blomback opened discussion to comments from the public.
 - **Matt Center, of Dodge Hill Rd, asked clarifying questions.**
 - **AJ Heinrich, of Snowshoe Rd, asked clarifying questions.**
- Chairman Blomback closed the hearing to public comment.

Selectman Marko moved to support Warrant Article #3 Wastewater Bond/Note, seconded by Selectman Morse. Motion carried 4-0-1 (Selectmen Martin Absent)

2024 HEARING WARRANT ARTICLE #4 FOR CONSERVATION COMMISSION BOND/NOTE

- Chairman Blomback opened the public hearing to borrow \$100,000 for Lake Management Consulting
- Mark Mitch, co-chairman of the Conservation Commission provided a summary of the project scope to hire a Lake Management Consulting Firm to study conditions and provide design solutions to reduce external and internal phosphate loading in French and Keyser Ponds -- to mitigate recurring Cyanobacteria algae blooms in these pond. The project will be funded 100% by \$100,000 in principal loan forgiveness under the New Hampshire Department of Environmental Services Clean Water State Revolving Fund.
- Chairman Blomback opened discussion to comments from the public.
 - **Matt Center, of Dodge Hill Rd, asked clarifying questions.**
 - **Mike French, of French Rd, spoke in support of this warrant article.**
- Chairman Blomback closed the hearing to public comment.

Selectman Marko moved to support Warrant Article #4 Conservation Commission Bond/Note, seconded by Selectman Morse. Motion carried 4-0-1. (Selectmen Martin Absent)

2024 HEARING ON WARRANTS GENERAL MUNICIPAL AND WASTEWATER OPERATIONAL BUDGETS, AND OTHER WARRANT ARTICLES

- Chairman Blomback opened the public hearing.

WARRANT ARTICLE #5 GENERAL MUNICIPAL OPERATIONS

DRAFT

Disclaimer – The following are Draft Minutes, which could include errors and are subject to change upon approval of the Select Board.

- Warrant Article #5 includes the operating budgets for all general fund operations except the Tucker Free Library which is included in another warrant article for a total of \$6,660,642. Department Heads, TA Kendall, FD Bradstreet presented the summary of budget requests provided line by line summary of department requests.

	2024 Requested	2023 Approved	Difference
EXECUTIVE	355,201	31,686	323,515
TOWN CLERK	107,782	94,275	13,507
ELECTIONS	29,986	6,620	23,366
TAX MAP	4,950	4,950	-
FINANCE	245,518	790,173	(544,655)
TAX COLLECTOR	114,689	94,525	20,164
ASSESSING	55,400	-	55,400
LEGAL	40,000	20,000	20,000
PLANNING	31,726	30,679	1,047
ZONING	5,271	5,271	-
GENERAL GOV'T BLDG	107,758	-	107,758
CEMETERIES	35,030	21,330	13,700
INSURANCE	169,674	156,615	13,059
MUNICIPAL DUES	4,043	4,157	(114)
POLICE	1,487,263	1,435,378	51,885
FIRE & RESCUE	793,503	732,465	61,038
RESCUE	128,997	124,159	4,838
FIRE	175,455	166,347	9,108
CODE	32,388	29,993	2,395
EMERGENCY MGT	5,493	1,292	4,201
HIGHWAY	902,646	861,750	40,896
HIGHWAY & STREETS	874,000	697,500	176,500
STREET LIGHTS	13,500	13,500	-
SOLID WASTE	478,739	584,000	(105,261)
HEALTH	5,883	-	5,883
ANIMAL CONTROL	5,340	9,408	(4,068)
WELFARE	91,702	80,000	11,702
ATHLETIC	32,645	32,645	-
PARKS & PROPERTY	59,249	-	59,249
PATRIOTIC PURPOSES	3,210	3,173	37
CONCERTS	21,726	7,195	14,531
CONSERVATION	2,946	2,890	56
COMMUNITY - CAP PROGRAM	14,000	14,000	-
COMMUNITY - WHITE BIRCH	65,000	65,000	-
DEBT SERVICE - PRINCIPAL	92,596	130,163	(37,567)
DEBT SERVICE - INTEREST	16,265	19,039	(2,774)
DEBT SERVICE - LEASE	37,568	-	37,568
DEBT SERVICE - TAN INTEREST	13,500	13,500	-
Totals	6,660,642	6,283,678	376,964

- The Board discussed the budget and asked TA Kendall to explain the request to include the conversion of the part-time assistant position to full-time status. **TA Kendall said the impact to the 2024 budget to converting the part-time admin position to full-time status is approximately \$17,000.**
- Selectman Marko noted his objection to the Executive Budget as presented because he is opposed to the additional cost of converting the part-time admin position to full-time.

DRAFT

Disclaimer – The following are Draft Minutes, which could include errors and are subject to change upon approval of the Select Board.

- Chairman Blomback opened discussion to comments from the public.
 - Heidi Aucoin, of Weare Rd, expressed concern about converting a position to full time and provided opinion on health insurance options.
 - Peter Flynn, of Main St, spoke in support converting the position to full time, and explained the positions, while reorganized in some duties were originally full time.
 - Rescue Chief Greg Aucoin spoke in support of converting the position to full time.
 - Matt Center, of Dodge Hill Rd, asked clarifying questions.
- Chairman Blomback closed the hearing to public comment. Board discussion ensued. Chairman Blomback asked the TA and FD if they could reduce another budget line item to offset the \$17,000 increase. Discussion ensued. Kendall and Bradstreet agreed they would reduce the department 4150 Finance by \$17,000 to offset the increase to 4130 Executive.

Chairman Blomback moved authorize the part-time to full-time reduce the finance budget by \$17,000; Selectman Marko seconded for discussion. Discussion ensued. Motion failed 2-2-1. (Selectman Marko and Selectman Osgood opposed, Selectmen Martin Absent)

Selectman Marko moved to not change the position from part to full time and to decrease the executive budget by \$17,000. Without a second the motion died.

Chairman Blomback moved to approve the Article #5 General Municipal Operations as presented, seconded by Selectman Morse. Motion carried 3-1-1 (Selectman Marko opposed, Selectmen Martin Absent)

WARRANT ARTICLE #6 APPROPRIATION TO CAPITAL RESERVE FUNDS

- TA Kendall and FD Bradstreet presented the summary of request to appropriate funds to the Capital Reserve Funds for a total of \$470,000. Kendall explained the Capital Reserve are planned by recommendation of the Capital Improvement Plan and expenditure from the funds requires approval of the legislative body at Town Meeting.

Highway Equipment	200,000
Wastewater	100,000
Fire Equipment	100,000
Bridge Repair	25,000
Transfer Station	30,000
Property Revaluation	15,000
TOTAL	470,000

- Chairman Blomback opened discussion to comments from the public. No public input.
 - Chairman Blomback closed the hearing to public comment.
- Selectman Marko moved to support Warrant Article #6 Appropriation to Capital Reserve Funds, seconded by Selectman Morse. Motion carried 4-0-1 (Selectmen Martin Absent)**

WARRANT ARTICLE #7 APPROPRIATION TO AMBULANCE CAPITAL RESERVE

- Rescue Chief Aucoin explained the warrant article to add \$80,000 to the Ambulance Capital Reserve of which the amount of \$10,000 is to come from the Town of Bradford. If these funds are not received, the appropriation will be reduced to \$70,000.
- Chairman Blomback opened discussion to comments from the public. No public input.
- Chairman Blomback closed the hearing to public comment.

Selectman Marko moved to support Warrant Article #7 Ambulance Capital Reserve, seconded by Selectman Osgood. Motion carried 4-0-1 (Selectmen Martin Absent)

WARRANT ARTICLE #8 APPROPRIATION TO EXPENDABLE TRUST FUNDS

- TA Kendall and FD Bradstreet presented the summary of the request to appropriate funds to the Expendable Trust Funds for a total of \$855,000. Expendable Trusts Funds may be expended upon approval of the agents to expend.

DRAFT

Disclaimer – The following are Draft Minutes, which could include errors and are subject to change upon approval of the Select Board.

Road Maintenance	700,000
Police Department Site Purchase, Building Engineering, Design and Construction	100,000
Fire & Rescue Building Maintenance	25,000
Police Department Equipment	10,000
Town Owned Building	10,000
Highway Building Maintenance	5,000
Parks	2,500
Town Technology	2,500
TOTAL	855,000

- Chairman Blomback opened discussion to comments from the public. No public input.
- Chairman Blomback closed the hearing to public comment.

Selectman Marko moved to support Warrant Article #8 Appropriation to Expendable Trust Funds, seconded by Selectman Morse. Motion carried 4-0-1 (Selectmen Martin Absent)

WARRANT ARTICLE #9 APPROPRIATION FROM HIGHWAY EQUIPMENT CAPITAL RESERVE FUND

- Highway Superintendent Leo Aucoin to explain the request to withdraw \$305,000 from the Highway Capital Reserve Funds to purchase a New Highway Dump/Plow Truck. Board discussion ensued.
- Chairman Blomback opened discussion to comments from the public. No public input.
- Chairman Blomback closed the hearing to public comment.

Selectman Marko moved to support Warrant Article #9 Highway Equipment Capital Reserve, seconded by Selectman Osgood. Motion carried 4-0-1 (Selectmen Martin Absent)

Chairman Blomback asked Library Trustees if they objected to allowing Wastewater Superintendent Slager ahead in the agenda. With no objection the board proceeded to Agenda item #20 Warrant Article 13 Wastewater Operation Budget.

WARRANT ARTICLE #13 WASTEWATER OPERATION BUDGET

- Richard Slager, Wastewater Superintendent provided a summary of the wastewater budget totaling \$780,792 to the Board of Selectmen/Wastewater Commissioners. Board discussion ensued.
- Chairman Blomback opened discussion to comments from the public. No public input.
- Chairman Blomback closed the hearing to public comment.

Selectman Marko moved to support Warrant Article #13 Wastewater Operation Budget, seconded by Selectman Osgood. Motion carried 4-0-1 (Selectmen Martin Absent)

WARRANT ARTICLE #10 APPROPRIATE GRANT FUNDS FOR TUCKER FREE LIBRARY

- Library Trustee Joe Petrick provided a summary of the request to raise and appropriate \$20,000 for purpose of continued restoration of granite and mortar on the exterior of the Tucker Free Library to be offset 100% by a Conservation License Plate Grant Program offered through the State of New Hampshire.
- Chairman Blomback opened discussion to comments from the public. No public input.
- Chairman Blomback closed the hearing to public comment.

Selectman Marko moved to support Warrant Article #10 Grant Funds for Tucker Free Library, seconded by Selectman Osgood. Motion carried 4-0-1 (Selectmen Martin Absent)

WARRANT ARTICLE #11 APPROPRIATE FUNDS FOR THE TUCKER FREE LIBRARY OPERATION

- Library Trustee Joe Petrick provided a summary of the request to raise and appropriate \$266,244 to support Tucker Free Library operating expenses.
- Chairman Blomback opened discussion to comments from the public. AJ Heinrich, of Snowshoe Rd, spoke in opposition to the library operating budget.
- Chairman Blomback closed the hearing to public comment.

DRAFT

Disclaimer – The following are Draft Minutes, which could include errors and are subject to change upon approval of the Select Board.

Selectman Marko moved to support Warrant Article #11 Appropriate Funds for the Tucker Free Library Operation, seconded by Selectman Osgood. Motion carried 4-0-1 (Selectmen Martin Absent)

WARRANT ARTICLE #12 APPROPRIATION TO LIBRARY ACCESSIBILITY AND SAFETY PROJECT EXPENDABLE TRUST

- Library Trustee Joe Petrick provided a summary of the request to raise and appropriate \$10,000 to fund the Library Accessibility and Safety Expendable Trust Fund.
- Chairman Blomback opened discussion to comments from the public. AJ Heinrich, of Snowshoe Rd, provided objection to the warrant article.
- Chairman Blomback closed the hearing to public comment. Board discussion and questions ensued. Selectman Marko explained the CIP Committee endorsed the funding request.

Selectman Marko moved to support Warrant Article #12 Appropriation to the Library Accessibility and Safety Project Expendable Trust, seconded by Selectman Osgood. Motion carried 4-0-1. (Selectmen Martin Absent)

WARRANT ARTICLE #14 COGSWELL SPRING WATER OPERATION BUDGET

- TA Kendall explained the Cogswell Spring Water Operation Budget of \$514,616 was adopted by the Water Commissioners after a duly noticed public hearing.
- Selectman Marko noted that the Cogswell Spring Water Operation Budget does not fall under the purview of the Board of Selectmen.
- Chairman Blomback opened discussion to comments from the public. Matt Center, of Dodge Hill Rd, asked clarifying questions.
- Chairman Blomback closed the hearing to public comment.

Chairman Blomback moved to support Warrant Article #14 Cogswell Spring Water Operation Budget, seconded by Selectman Morse. Motion carried 3-0-2. (Selectman Marko abstained, Selectmen Martin Absent)

Rescue Chief Greg Aucoin requested to the Boards consideration of a warrant article to authorize expenditure of funds from the Ambulance Capital Reserve Fund to appropriate the sum of One Hundred \$141,202 for the purchase of a New Rescue Ambulance Chassis and Re-boxing of the 2016 ambulance body. Chief Aucoin and TA Kendall explained the omission of the article from the Draft warrant was an error. Chief Aucoin explained, in 2023 the legislative body authorized \$64,000 withdrawal from the fund for the purchase of an ambulance cab and chassis.

- Board discussion ensued.
- Chairman Blomback directed TA Kendall and FD Bradstreet to craft the warrant article language.
- Chairman Blomback opened the discussion to comments from the public. No public input.
- Chairman Blomback closed public comment.

Selectman Marko moved support a warrant article to see if the Town will vote to raise and appropriate the sum of One Hundred Forty-One Thousand Two Hundred-Two Dollars (\$141,202) for the purchase of a New Rescue Ambulance Chassis and Re-boxing of the 2016 ambulance body and authorize the withdrawal of One Hundred Forty-One Thousand Two Hundred-Two Dollars (\$141,202) from the Ambulance Capital Reserve Fund. Seconded by Selectman Morse. Motion carried 4-0-1 (Selectmen Martin Absent)

Chairman Blomback asked if there was any more public input before closing the public hearing on the 2024 general operating budget and other Warrant Articles.

- Ms. Marko also inquired about the balance of total unpaid taxes. FD Bradstreet shared the balance is approximately \$1.1 million at the end of 2023. FD Bradstreet also share there was approximately \$800,000 in ambulance receivables. Ms. Marko expressed concern that budget increases would affect those already struggling to pay their taxes.
- Allison Mrohs, of Ramsdell Rd, addressed a typographical error in the petition warrant article request to eliminate monthly meeting space rental fees paid by an organization whose efforts benefit residents of Henniker. TA Kendall will make the correction.

DRAFT

Disclaimer – The following are Draft Minutes, which could include errors and are subject to change upon approval of the Select Board.

ADJOURNMENT

Chairman Blomback closed the public hearing on the 2024 Hearing on Warrants General Municipal and Wastewater Operational Budgets, and Other Warrant Articles.

Selectman Marko motioned to adjourn at 9:48 PM, seconded by Selectman Morse. The motion passed, unanimously.

Respectfully submitted,

Minute Taker

Minutes Approved:



Meeting: BOARD OF SELECTMEN

Date: February 13, 2024

PLEASE PRINT

Name	Address
Sherry Bradstreet	France
Marc Boirvert	Transfer Station
Loyd Marko	Henniker
Richard Sleser	clarendon
Joe Patrick	Henniker
SUSAN ADAMS	Ramsdell Rd.
Alumkinds	10 Ramsdell Rd
J Scott Osmond	128 Foster
A.J. Heinrich	133 Snowshoe Rd
L1 Parker	521 Liberty Hill
Lynn Piotrowski	Taken Free Library
Kirk Spufford	Western Ave
Maric Mitch	Henniker
Greg Auccin	Henniker, Fairview Ave
Matthew French	HPD
Matt Center	Unc Dodge Hill Rd.
Richard Dreher	150 Maple St
Correll Johnston	480 Shaker Hill Rd
Stephanie Teas	179 Shore Rd.
Loe Krueger	68 Juniper Ridge
Rueh Jay	247 Hall Ave
Danny & Heidi Arcum	2460 Weare Rd

TOWN ADMINISTRATOR REPORT

CORRESPONDENCE

Cogswell Spring Water Works



Town of Henniker Water Department
146 Davison Road, Henniker, NH 03242

2/5/2024

TO:

Senator Jeane Shaheen,
and
Senator Margaret Hassan
and
Representative Chris Pappas
and
Representative Ann Kuster

RE: Town of Henniker Water System Requesting your assistance with an existing water supply well on United States Army Corps of Engineers (USACE) land and amending an agreement

Dear Senator Shaheen, Senator Hassan, Representative Pappas and Representative Kuster;

Cogswell Springs Water Works CSWW, which is the Town of Henniker Water Dept, is requesting your assistance with a water supply issue. Specifically, CSWW sent a letter to the USACE on 10/13/2022 to formally request a change to the USACE Supplemental Agreement No. 8 to allow the withdrawal of water from the water well (see attached copy of letter and agreements).

Unfortunately, to date we have only received correspondence via emails that the situation is being investigated without any real answer to our request (see attached emails).

The original April 1, 1980, signed lease agreement allowed the Town of Henniker to withdraw water from a groundwater water supply well situated on USACE land. Unfortunately, a supplemental Agreement No. 6 to the lease dated April 15, 2014, revised the withdrawal to state "2. Effective October 1, 2013, the lessee is prohibited from withdrawing water from the leased premises. The lessee may take water samples for water quality monitoring purposes only."

This water source is a valuable resource to the Town of Henniker as a backup and to provide redundancy in the event that the two existing wells are not available to provide water to the town or in the event of a watermain break across the Contoocook River.

CSWW is requesting your assistance to contact the USACE to amend the USACE lease agreement to allow the withdrawal of water from the approved well and that the amended agreement does not contain a clause whereas the USACE would assess a fee for water withdrawal.

Any assistance regarding this matter will be appreciated. We thank you in advance and look forward to the successful resolution of the matter.

Sincerely,

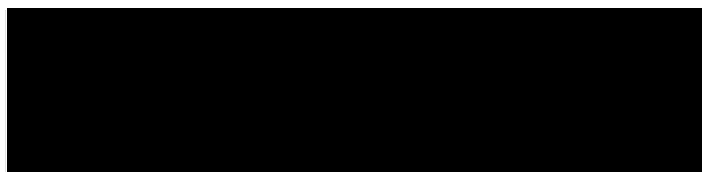
A large black rectangular redaction box covering the signature area.

James Donison, P.E. Superintendent

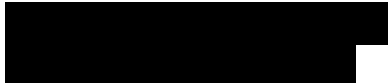
A black rectangular redaction box covering the contact information.

603-428-3237

CC: Diane Kendall, Town of Henniker Town Administrator

DEPARTMENT REPORTS

January 2024 Department Reports

Assessing Department

Building Department

Finance Department

Fire Department

Highway Department

Town Clerk/Tax Collector

Transfer Station/Parks & Properties

Wastewater Treatment Plant

MEMORANDUM

Helga Winn, Assessing Technician
18 Depot Hill Road
Henniker, NH 03242
Phone 603-428-3221 x 1 ≈≈ Fax 603-428-4366



TO: Diane Kendall, Town Administrator
DATE: February 6, 2024
RE: Monthly Report

Assessing Report for January 2024

- Monthly maintenance of new deeds, address changes, and GIS updates.
- Permit tracking in Avitar as needed.
- Two Intents to Cut received.
- Four abatement applications received.
- One solar exemption application received.
- Completed Town Valuation of Exempt Properties report for Town Report.
- 5-year review letters sent to taxpayers who receive elderly/disabled exemptions and veteran's credits.
- Lot changes due to lot line adjustments, subdivisions, acreage changes, and mergers, etc. compiled and reviewed by Assessor's as part of the annual pick-ups.
- Field work of 2024 cyclical inspections and pick-ups began.
- Warrant for Cogswell Spring Water Works created for first billing.
- Continued review of all current use properties with stewardships.
- Ongoing filing of deed backlog.



Monthly Building Department Report January 2024

TO: Diane Kendall, Town Administrator

FROM: Hank Bernstein, Land Use and General Administrative Assistant

The following is a record of permits, certificates of occupancy, inspections and revenue collected for the month listed above.

Permits	Quantity	Revenue
Building - Residential	1	\$190.40
Building - Commercial	0	\$0.00
Electrical	5	\$300.00
Plumbing	2	\$150.00
Mechanical	4	\$250.00
Demolition	0	\$0.00
Driveway	1	\$75.00
Trench	0	\$0.00
Sign	0	\$0.00
Assembly	1	\$0.00
Raffle	2	\$0.00
Tent	0	\$0.00
Hawk & Peddler	0	\$0.00
Total # of Permits	16	\$965.40
Inspections Performed	14	
Certificates of Occupancy	2	

Town building rental/use:

Town Buildings	Rented/Reserved	Revenue
Community Center (upstairs)	1	\$200.00
Grange <i>(Does not include Caseworker & CAP)</i>	Food Pantry open twice a week Al-Anon every Sunday 1	Food Pantry-permanent No Charge for AA \$25.00
Bandstand/Community Park	0	\$0.00
Total:	6	\$225.00

Respectfully submitted,
Hank Bernstein

Town of Henniker, NH

Permits Issued January 2024

Date In	Owner	Address	Map/Lot	Type	Description	Contractor	Estimated cost	Fees	Issue Date
1/2/2024	New England College	58 Depot Hill Rd	5D-425	Mechanical	revising heat piping & duct work and add appliances	Precision Temperature Control, Inc		\$100.00	1/2/2024
1/2/2024	New England College	58 Depot Hill Rd	5D-425	Plumbing	New Sinks and eyewash	Precision Temperature Control, Inc		\$100.00	1/2/2024
12/20/2023	Forrestall, Rebecca	100 Elm St	9-540-X4A	Building	27 panel rm solar arra; 8.64kW, No ESS	Summit Energy Group	\$44,384.76	\$190.40	1/3/2024
12/20/2023	Forrestall, Rebecca	100 Elm St	9-540-X4A	Electrical	27 panel rm solar arra; 8.64kW, No ESS	Summit Energy Group		\$50.00	1/3/2024
1/5/2024	Laliberte, Paul & Lianna	1493 Western Ave	7-569	Plumbing	Plumbing for new construction	Next Gen Plumbing & Heating		\$50.00	1/5/2024
1/5/2024	New England College	58 Depot Hill Rd	5D-425	Electrical	Lighting, Power, and Alarm Systems	Wayne J Griffin Electric		\$100.00	1/10/2024
1/11/2024	Lyons, Melissa	175 Elm St	9-541	Mechanical	Install piping for wall heater	Shawn Oesterreich		\$50.00	1/11/2024
1/16/2024	Laliberte, Paul & Lianna	1493 Western Ave	7-569	Electrical	Install service & wiring for house & ADU	Libby Contracting & Electric LLC		\$50.00	1/16/2024
1/17/2024	State 9 Racing	Various Roads	8-588-A	Special Event	Bicycle Race	State 9 Racing		\$0.00	1/16/2024
1/18/2024	Canty, Jeanne	284 Butter Rd	8-577-X1	Mechanical	Generac Generator	JN Electric LLC		\$50.00	1/19/2024
1/18/2024	Canty, Jeanne	284 Butter Rd	8-577-X1	Electrical	18kW Generator; 200A ATS, Replacement of existing service panel	JN Electric LLC		\$50.00	1/19/2024
1/23/2024	Laliberte, Paul & Lianna	1493 Western Ave	7-569	Mechanical	Two nes Gas furnaces and piping	AJ Lebanc Heating		\$50.00	1/24/2024
1/24/2024	Judith Perrotti			Raffle	50/50	Lions Club		\$0.00	1/24/2024
1/26/2024	Concert Committee	Community Center		Raffle	Ice Cream, possible 50/50	Ruth Zax		\$0.00	1/29/2024
1/25/2024	Woodhill LLC	Foster Hill Rd	6-278-B	Driveway	Temporary Logging Driveway	Sterling Timber		\$75.00	1/30/2024
1/31/2024	Simeone, David & Val	231 Highland	9-554-32	Electrical	Heat Pump	Trombly Enterprises		\$50.00	1/31/2024

DEPARTMENTAL HOURS AND GROSS SUMMARY REPORT FOR TOWN OF HENNIKER
For 01/01/2024 to 01/31/2024

Pay Code	Regular Hours	Suppl. Hours	Regular Gross	OT Hours	OT Gross
Department: CODE CODE					
Department Totals For: CODE					
GASOLINE	0.00	0.00	200.00	0.00	0.00
SALARY	90.00	0.00	2,427.85	0.00	0.00
Totals:	90.00	0.00	2,627.85	0.00	0.00
Department: CSWW CSWW					
Department Totals For: CSWW					
HOLIDAY	56.00	0.00	2,957.76	0.00	0.00
REGULAR	167.50	0.00	8,007.61	0.00	0.00
SICK	1.00	0.00	69.93	0.00	0.00
Totals:	224.50	0.00	11,035.30	0.00	0.00
Department: ELECTION ELECTION					
Department Totals For: ELECTION					
REGULAR	87.50	0.00	634.39	0.00	0.00
Totals:	87.50	0.00	634.39	0.00	0.00
Department: EXECUTIVE EXECUTIVE					
Department Totals For: EXECUTIVE					
BEREAVEMENT	24.00	0.00	685.92	0.00	0.00
CELL PHONE	0.00	0.00	75.00	0.00	0.00
HOLIDAY	86.00	0.00	2,650.21	0.00	0.00
REGULAR	208.00	0.00	4,637.85	0.00	0.00
SALARY	213.00	0.00	8,816.50	0.00	0.00
SICK	30.00	0.00	792.60	0.00	0.00
USECOMP	33.00	0.00	943.14	0.00	0.00
VACATION	7.25	0.00	128.91	0.00	0.00
Totals:	601.25	0.00	18,730.13	0.00	0.00
Department: FINANCE FINANCE					
Department Totals For: FINANCE					
DISABILITY	0.00	0.00	2,444.28	0.00	0.00
HOLIDAY	40.00	0.00	1,318.24	0.00	0.00
SALARY	189.50	0.00	7,314.56	0.00	0.00
Totals:	229.50	0.00	11,077.08	0.00	0.00
Department: FIRE FIRE					
Department Totals For: FIRE					
FIRE MEETING	5.00	0.00	1.25	0.00	0.00
REGULAR	105.00	0.00	1,548.00	0.00	0.00
STIPEND	0.00	0.00	2,083.33	0.00	0.00
Totals:	110.00	0.00	3,632.58	0.00	0.00
Department: FIRE/RESCUE FIRE/RESCUE					
Department Totals For: FIRE/RESCUE					
FIRE MEETING	2.00	0.00	0.50	0.00	0.00
OVERTIME	0.00	0.00	0.00	26.50	959.43
REGULAR	558.75	0.00	11,648.32	0.00	0.00
STIPEND	0.00	0.00	2,695.51	0.00	0.00
Totals:	560.75	0.00	14,344.33	26.50	959.43
Department: HIGHWAY HIGHWAY					
Department Totals For: HIGHWAY					
CELL PHONE	0.00	0.00	130.00	0.00	0.00
FT LONGEVITY	0.00	0.00	500.00	0.00	0.00

DEPARTMENTAL HOURS AND GROSS SUMMARY REPORT FOR TOWN OF HENNIKER

For 01/01/2024 to 01/31/2024

Pay Code	Regular Hours	Suppl. Hours	Regular Gross	OT Hours	OT Gross
HOLIDAY	144.00	0.00	3,969.60	0.00	0.00
MILEAGE	0.00	0.00	340.00	0.00	0.00
OVERTIME	0.00	0.00	0.00	402.75	17,317.18
REGULAR	1,086.50	0.00	30,439.94	0.00	0.00
SICK	51.00	0.00	1,271.32	0.00	0.00
SICK BUYOUT	5.75	0.00	171.58	0.00	0.00
USECOMP	1.00	0.00	26.40	0.00	0.00
VACATION	36.50	0.00	942.76	0.00	0.00
Totals:	1,324.75	0.00	37,791.60	402.75	17,317.18

Department: LIBRARY LIBRARY

Department Totals For: LIBRARY

REGULAR	427.25	0.00	9,058.87	0.00	0.00
SALARY	200.00	0.00	8,042.00	0.00	0.00
Totals:	627.25	0.00	17,100.87	0.00	0.00

Department: POLICE POLICE

Department Totals For: POLICE

EVENING OT	0.00	0.00	0.00	26.00	1,135.14
EVENING PAY	453.50	0.00	14,168.53	0.00	0.00
HOLIDAY	48.00	0.00	1,189.12	0.00	0.00
MIDNIGHT OT	0.00	0.00	0.00	3.00	111.11
MIDNIGHT PAY	421.25	0.00	10,588.78	0.00	0.00
OUTSIDE DETAIL	90.00	0.00	4,061.70	0.00	0.00
REGULAR	923.75	0.00	30,334.11	0.00	0.00
REGULAR OT	0.00	0.00	0.00	50.00	2,378.69
SICK	48.00	0.00	1,609.26	0.00	0.00
SICK BUYOUT	17.20	0.00	717.24	0.00	0.00
USECOMP	42.50	0.00	1,077.80	0.00	0.00
VACATION	144.00	0.00	4,898.52	0.00	0.00
Totals:	2,188.20	0.00	68,645.06	79.00	3,624.94

Department: RESCUE RESCUE

Department Totals For: RESCUE

COMP OVER BASE	4.50	0.00	116.79	0.00	0.00
HALFTIME - FIRE	24.00	0.00	327.00	0.00	0.00
HOLIDAY	128.50	0.00	3,517.48	0.00	0.00
OVERTIME	0.00	0.00	0.00	124.50	4,535.18
REGULAR	1,263.25	0.00	32,473.17	0.00	0.00
SICK	32.00	0.00	842.80	0.00	0.00
VACATION	24.00	0.00	654.00	0.00	0.00
Totals:	1,476.25	0.00	37,931.24	124.50	4,535.18

Department: SW/GGB/P&P SOLID WASTE/GEN GOV BLDG/P&P

Department Totals For: SW/GGB/P&P

HOLIDAY	145.00	0.00	3,412.78	0.00	0.00
OVERTIME	0.00	0.00	0.00	17.00	608.20
PT LONGEVITY	0.00	0.00	500.00	0.00	0.00
REGULAR	659.00	0.00	15,144.43	0.00	0.00
SICK	13.00	0.00	328.77	0.00	0.00
VACATION	22.00	0.00	591.50	0.00	0.00
Totals:	839.00	0.00	19,977.48	17.00	608.20

Department: TC/TX TOWN CLERK / TAX COLLECTOR

Department Totals For: TC/TX

HOLIDAY	67.00	0.00	1,757.65	0.00	0.00
OVERTIME	0.00	0.00	0.00	9.00	269.47
REGULAR	168.00	0.00	3,353.28	0.00	0.00
SALARY	188.25	0.00	5,365.63	0.00	0.00
Totals:	423.25	0.00	10,476.56	9.00	269.47

DEPARTMENTAL HOURS AND GROSS SUMMARY REPORT FOR TOWN OF HENNIKER

For 01/01/2024 to 01/31/2024

Pay Code	Regular Hours	Suppl. Hours	Regular Gross	OT Hours	OT Gross
Department: WELFARE WELFARE					
Department Totals For: WELFARE					
HOLIDAY	9.00	0.00	191.16	0.00	0.00
REGULAR	45.50	0.00	966.42	0.00	0.00
SICK	2.00	0.00	42.48	0.00	0.00
VACATION	3.50	0.00	74.34	0.00	0.00
Totals:	60.00	0.00	1,274.40	0.00	0.00
Department: WWTP WASTE WATER TREATMENT PLANT					
Department Totals For: WWTP					
HOLIDAY	96.00	0.00	2,741.76	0.00	0.00
OVERTIME	0.00	0.00	0.00	20.00	850.77
REGULAR	445.50	0.00	12,723.44	0.00	0.00
SICK	48.00	0.00	1,376.94	0.00	0.00
USECOMP	7.50	0.00	187.13	0.00	0.00
VACATION	3.00	0.00	106.74	0.00	0.00
Totals:	600.00	0.00	17,136.01	20.00	850.77
Grand Totals:					
BEREAVEMENT	24.00	0.00	685.92	0.00	0.00
CELL PHONE	0.00	0.00	205.00	0.00	0.00
COMP OVER BASE	4.50	0.00	116.79	0.00	0.00
DISABILITY	0.00	0.00	2,444.28	0.00	0.00
EVENING OT	0.00	0.00	0.00	26.00	1,135.14
EVENING PAY	453.50	0.00	14,168.53	0.00	0.00
FIRE MEETING	7.00	0.00	1.75	0.00	0.00
FT LONGEVITY	0.00	0.00	500.00	0.00	0.00
GASOLINE	0.00	0.00	200.00	0.00	0.00
HALFTIME - FIRE	24.00	0.00	327.00	0.00	0.00
HOLIDAY	819.50	0.00	23,705.76	0.00	0.00
MIDNIGHT OT	0.00	0.00	0.00	3.00	111.11
MIDNIGHT PAY	421.25	0.00	10,588.78	0.00	0.00
MILEAGE	0.00	0.00	340.00	0.00	0.00
OUTSIDE DETAIL	90.00	0.00	4,061.70	0.00	0.00
OVERTIME	0.00	0.00	0.00	599.75	24,540.23
PT LONGEVITY	0.00	0.00	500.00	0.00	0.00
REGULAR	6,145.50	0.00	160,969.83	0.00	0.00
REGULAR OT	0.00	0.00	0.00	50.00	2,378.69
SALARY	880.75	0.00	31,966.54	0.00	0.00
SICK	225.00	0.00	6,334.10	0.00	0.00
SICK BUYOUT	22.95	0.00	888.82	0.00	0.00
STIPEND	0.00	0.00	4,778.84	0.00	0.00
USECOMP	84.00	0.00	2,234.47	0.00	0.00
VACATION	240.25	0.00	7,396.77	0.00	0.00
Totals:	9,442.20	0.00	272,414.88	678.75	28,165.17

BUDGET REPORT FOR TOWN OF HENNIKER

Calculations As of 01/31/2024

GL Number	Description	2024		2024	
		PUBLIC HEARING	FINAL	Activity	PUBLIC HEARING FINAL
Fund: 01 GENERAL FUND					
EXECUTIVE					
01-4130-4110-000	WAGES FT	195,159.00		22,028.65	173,130.35
01-4130-4111-000	WAGES PT	7,073.00		3,920.50	3,152.50
01-4130-4115-001	SELECTMEN STIPEND	7,500.00			7,500.00
01-4130-4140-000	OVERTIME	1,000.00			1,000.00
01-4130-4211-000	BENEFIT INSURANCE	66,006.00		10,040.66	55,965.34
01-4130-4220-000	FICA/MEDICARE	16,121.00		1,920.56	14,200.44
01-4130-4230-000	RETIREMENT	12,096.00			12,096.00
01-4130-4231-000	TA RETIREMENT	14,595.00		1,897.77	12,697.23
01-4130-4330-000	TUITUIN REIMBURSE	7,500.00			7,500.00
01-4130-4341-000	TELEPHONE CHGS	900.00		150.00	750.00
01-4130-4550-000	PRINTING	500.00			500.00
01-4130-4552-000	TOWN REPORT	2,900.00			2,900.00
01-4130-4560-000	DUES/MEMBERSHIPS	850.00		40.00	810.00
01-4130-4570-000	ADVERTISING	1,800.00		338.00	1,462.00
01-4130-4610-000	SELECTMEN EXPENSE	2,000.00			2,000.00
01-4130-4614-000	LOSS PREVENTION	300.00			300.00
01-4130-4615-000	HISTORIC DISTRICT	1.00			1.00
01-4130-4620-000	OFFICE SUPPLIES	4,000.00			4,000.00
01-4130-4625-000	POSTAGE	1,000.00			1,000.00
01-4130-4637-000	MILEAGE	500.00			500.00
01-4130-4810-000	INFORMATION TECHNOLOGY	13,400.00		640.00	12,760.00
Total Department EXECUTIVE:		355,201.00		40,976.14	314,224.86
TOWN CLERK					
01-4140-4111-000	WAGES DEPUTY CLERK	21,537.00		2,714.79	18,822.21
01-4140-4130-000	STIPEND - TOWN CLERK	34,561.00		4,525.06	30,035.94
01-4140-4140-000	OVERTIME - DEPUTY CLERK	1,556.00		11.26	1,544.74
01-4140-4211-000	BENEFIT INSURANCE	25,131.00		4,340.94	20,790.06
01-4140-4220-000	FICA/MEDICARE	4,411.00		528.47	3,882.53
01-4140-4230-000	RETIREMENT	7,801.00			7,801.00
01-4140-4240-000	TRAINING/SEMINARS	1,500.00			1,500.00
01-4140-4560-000	DUES/MEMBERSHIPS	60.00			60.00
01-4140-4570-000	ADVERTISING	200.00			200.00
01-4140-4620-000	OFFICE SUPPLIES	1,400.00		23.98	1,376.02
01-4140-4625-000	POSTAGE	2,500.00			2,500.00
01-4140-4637-000	MILEAGE	550.00			550.00
01-4140-4810-000	INFORMATION TECHNOLOGY	4,930.00		282.00	4,648.00
01-4140-4814-000	PHOTOCOPY EXPENSE	490.00			490.00
01-4140-4815-000	PRINTER USAGE	705.00		83.37	621.63
01-4140-4832-000	ANIMAL LICENSES	450.00			450.00
Total Department TOWN CLERK:		107,782.00		12,509.87	95,272.13
ELECTIONS					
01-4141-4110-001	WAGES FULL TIME DEP CLERK	1,780.00		179.64	1,600.36
01-4141-4110-002	WAGES FULL TIME PARKS AND PRO	759.00			759.00
01-4141-4111-000	WAGES PART TIME BALLOT CLERK	6,048.00		634.39	5,413.61
01-4141-4111-001	WAGES PART TIME PARKS AND PRO	0.00		119.91	(119.91)
01-4141-4115-000	STIPEND SUPERVISORS OF CHECKL	3,900.00			3,900.00
01-4141-4140-000	OVERTIME DEPUTY CLERK	0.00		247.01	(247.01)
01-4141-4140-001	OVERTIME PARKS AND PROPERTIES	0.00		265.55	(265.55)
01-4141-4220-000	FICA/MEDICARE	955.00		108.81	846.19
01-4141-4230-000	RETIREMENT	344.00			344.00
01-4141-4570-000	ADVERTISING	200.00			200.00
01-4141-4620-000	VOTING SUPPLIES	200.00			200.00
01-4141-4625-000	POSTAGE	700.00			700.00
01-4141-4690-000	ELECTION EXPENSE	1,000.00		296.75	703.25
01-4141-4740-000	EQUIPMENT PURCHASE	8,000.00			8,000.00
01-4141-4802-000	BALLOTS	6,000.00		1,042.00	4,958.00
01-4141-4803-000	VOTING BOOTH MAINT.	100.00			100.00
Total Department ELECTIONS:		29,986.00		2,894.06	27,091.94
TAX MAP					
01-4142-4312-000	CARTOGRAPHER	2,400.00		575.00	1,825.00
01-4142-4400-000	DIGITAL MAPPING	2,300.00			2,300.00
01-4142-4550-000	PRINTING	250.00			250.00
Total Department TAX MAP:		4,950.00		575.00	4,375.00
FINANCE					
01-4150-4110-000	WAGES FT	127,211.00		13,026.98	114,184.02
01-4150-4112-000	WAGES PART TIME	1.00			1.00

BUDGET REPORT FOR TOWN OF HENNIKER

Calculations As of 01/31/2024

GL Number	Description	2024		2024	
		PUBLIC HEARING	FINAL	Activity	PUBLIC HEARING FINAL
Fund: 01 GENERAL FUND					
FINANCE					
01-4150-4115-001	TREASURER STIPEND		1,500.00		1,500.00
01-4150-4115-002	DEPUTY TREASURER STIPEND		100.00		100.00
01-4150-4115-003	STIPEND		900.00		900.00
01-4150-4211-000	BENEFIT INSURANCE		16,520.00	2,012.96	14,507.04
01-4150-4220-000	FICA/MEDICARE		10,486.00	1,154.53	9,331.47
01-4150-4230-000	RETIREMENT		18,208.00		18,208.00
01-4150-4240-000	TRAINING/SEMINARS		1,000.00		1,000.00
01-4150-4301-000	CONSULT/AUDITORS		16,000.00		16,000.00
01-4150-4310-000	CONSULTANT - ROBERT HALF		4,850.00	2,710.32	2,139.68
01-4150-4341-000	TELEPHONE CHGS		6,000.00	462.99	5,537.01
01-4150-4550-000	PRINTING		1,000.00		1,000.00
01-4150-4560-000	DUES/MEMBERSHIP		200.00		200.00
01-4150-4620-000	OFFICE SUPPLIES		500.00	384.32	115.68
01-4150-4625-000	POSTAGE		6,200.00		6,200.00
01-4150-4637-000	MILEAGE		500.00		500.00
01-4150-4670-000	BOOKS		0.00	286.00	(286.00)
01-4150-4740-000	EQUIPMENT PURCHASE		1,000.00		1,000.00
01-4150-4810-000	INFORMATION TECHNOLOGY		0.00	2,688.02	(2,688.02)
01-4150-4810-001	INFORMATION TECH - SOFTWARE		15,000.00		15,000.00
01-4150-4810-002	INFORMATION TECH - SUPPORT		16,692.00		16,692.00
01-4150-4815-000	COPIER LEASE		1,650.00	218.21	1,431.79
Total Department FINANCE:			245,518.00	22,944.33	222,573.67
TAX COLLECTOR					
01-4151-4111-000	WAGES DEPUTY		21,537.00	2,714.33	18,822.67
01-4151-4130-000	WAGES		34,561.00	4,525.38	30,035.62
01-4151-4140-000	OVERTIME		1,556.00	11.20	1,544.80
01-4151-4211-000	BENEFIT INSURANCE		25,132.00	4,340.94	20,791.06
01-4151-4220-000	FICA/MEDICARE		4,411.00	528.38	3,882.62
01-4151-4230-000	RETIREMENT		7,801.00		7,801.00
01-4151-4240-000	TRAINING/SEMINAR		1,000.00		1,000.00
01-4151-4560-000	DUES/MEMBERSHIP		60.00		60.00
01-4151-4570-000	ADVERTISING		200.00		200.00
01-4151-4620-000	OFFICE SUPPLIES		1,300.00	16.82	1,283.18
01-4151-4625-000	POSTAGE		5,000.00		5,000.00
01-4151-4637-000	MILEAGE		350.00		350.00
01-4151-4810-000	INFORMATION TECHNOLOGY		6,281.00	282.00	5,999.00
01-4151-4814-000	PHOTOCOPY EXP		500.00		500.00
01-4151-4825-000	COUNTY REGISTRY		700.00		700.00
01-4151-4827-000	LEIN RESEARCH		4,300.00		4,300.00
Total Department TAX COLLECTOR:			114,689.00	12,419.05	102,269.95
ASSESSING					
01-4152-4312-001	CONSULTANT GEN ASSESSING		39,300.00		39,300.00
01-4152-4312-002	CONSULTANT UTILITY ASSESSING		10,000.00		10,000.00
01-4152-4312-003	CONSULTANT TIMBER ASSESSING		600.00		600.00
01-4152-4810-000	INFORMATION TECHNOLOGY		5,500.00		5,500.00
Total Department ASSESSING:			55,400.00	0.00	55,400.00
LEGAL					
01-4153-4320-000	LEGAL FEES - GENERAL		10,000.00	45.00	9,955.00
01-4153-4320-321	LEGAL FEES - PSNH		20,000.00		20,000.00
01-4153-4320-322	LEGAL FEES - CODE		5,000.00		5,000.00
01-4153-4320-323	LEGAL FEES - DEEDING		5,000.00		5,000.00
Total Department LEGAL:			40,000.00	45.00	39,955.00
PLANNING					
01-4191-4110-000	WAGES		1,500.00	31.12	1,468.88
01-4191-4220-000	FICA/MEDICARE		115.00	2.38	112.62
01-4191-4240-000	TRAINING/SEMINARS		250.00		250.00
01-4191-4390-000	CONSULTING FEES		21,450.00	2,880.00	18,570.00
01-4191-4560-000	DUES/MEMBERSHIPS		5,907.00	5,907.00	0.00
01-4191-4570-000	ADVERTISING		1,000.00		1,000.00
01-4191-4620-000	OFFICE SUPPLIES		300.00		300.00
01-4191-4625-000	POSTAGE		100.00		100.00
01-4191-4810-000	INFORMATION TECHNOLOGY		1,104.00	184.00	920.00
01-4191-4901-000	ESCROW ACCT EXPENSES		0.00	1,196.72	(1,196.72)
Total Department PLANNING:			31,726.00	10,201.22	21,524.78
ZONING					

BUDGET REPORT FOR TOWN OF HENNIKER

Calculations As of 01/31/2024

GL Number	Description	2024		2024	
		PUBLIC HEARING FINAL	Activity	PUBLIC HEARING FINAL	2024 Amt Change
Fund: 01 GENERAL FUND					
ZONING					
01-4192-4110-000	WAGES	600.00			600.00
01-4192-4220-000	FICA/MEDICARE	46.00			46.00
01-4192-4390-000	CONSULTANT	3,000.00	318.75		2,681.25
01-4192-4391-000	LEGAL	800.00			800.00
01-4192-4570-000	ADVERTISING	300.00			300.00
01-4192-4620-000	OFFICE SUPPLIES	225.00			225.00
01-4192-4625-000	POSTAGE	300.00			300.00
Total Department ZONING:		5,271.00	318.75		4,952.25
GENERAL GOVERNMENT BUILDINGS					
01-4194-4110-000	WAGES FULL TIME	15,092.00	1,150.36		13,941.64
01-4194-4111-000	WAGES PART TIME	24,947.00	2,093.55		22,853.45
01-4194-4140-000	OVERTIME	5,417.00	427.12		4,989.88
01-4194-4211-000	BENEFIT INSURANCE	2,150.00	386.36		1,763.64
01-4194-4220-000	FICA/MEDICARE	3,477.00	279.97		3,197.03
01-4194-4230-000	RETIREMENT	2,775.00			2,775.00
01-4194-4341-300	TELECOM - COMM CTR	1,635.00			1,635.00
01-4194-4409-100	CUSTODIAL SERVICE - TOWN HALL	6,480.00	532.21		5,947.79
01-4194-4409-200	CUSTODIAL SERVICE - GRANGE	5,400.00	443.51		4,956.49
01-4194-4409-300	CUSTODIAL SERVICE - COMM CTR	3,000.00	246.40		2,753.60
01-4194-4410-100	ELECTRICITY - TOWN HALL	3,600.00	266.92		3,333.08
01-4194-4410-200	ELECTRICITY - GRANGE	1,750.00	261.05		1,488.95
01-4194-4410-300	ELECTRICITY - COMM CTR	5,000.00	519.04		4,480.96
01-4194-4411-100	HEAT FUEL - TOWN HALL	6,000.00	358.65		5,641.35
01-4194-4411-200	HEAT FUEL - GRANGE	2,500.00			2,500.00
01-4194-4411-300	HEAT FUEL - COMM CTR	500.00			500.00
01-4194-4412-100	WATER/SEWER - TOWN HALL	1,135.00	327.60		807.40
01-4194-4412-200	WATER/SEWER - GRANGE	800.00	211.35		588.65
01-4194-4412-300	WATER/SEWER - COMM CTR	1,000.00	163.80		836.20
01-4194-4414-100	ALARM - TOWN HALL	1,000.00			1,000.00
01-4194-4414-200	ALARM - GRANGE	500.00			500.00
01-4194-4414-300	ALARM - COMM CTR	500.00			500.00
01-4194-4430-100	BLD REPAIR/MAINT - TOWN HALL	5,000.00	77.00		4,923.00
01-4194-4430-200	BLD REPAIR/MAINT - GRANGE	1,000.00			1,000.00
01-4194-4430-300	BLD REPAIR/MAINT - COMM CTR	1,500.00			1,500.00
01-4194-4689-100	SUPPLIES OTHER - TOWN HALL	1,600.00			1,600.00
01-4194-4689-200	SUPPLIES OTHER - GRANGE	500.00			500.00
01-4194-4689-300	SUPPLIES OTHER - COMM CTR	500.00			500.00
01-4194-4740-100	EQUIPMENT - TOWN HALL	1,000.00			1,000.00
01-4194-4740-200	EQUIPMENT - GRANGE	1,000.00			1,000.00
01-4194-4740-300	EQUIPMENT - COMM CTR	1,000.00			1,000.00
Total Department GENERAL GOVERNMENT BUILDING		107,758.00	7,744.89		100,013.11
CEMETERIES					
01-4195-4650-000	GROUND MAINT	11,780.00			11,780.00
01-4195-4655-000	STONE REPAIR	3,250.00			3,250.00
01-4195-4657-000	TREE REMOVAL	19,500.00			19,500.00
01-4195-4660-000	REPAIRS	500.00			500.00
Total Department CEMETERIES:		35,030.00	0.00		35,030.00
INSURANCE					
01-4196-4520-000	WORKERS COMPENSATION	55,573.00	55,573.00		0.00
01-4196-4522-000	GENERAL LIABILITY	111,192.00			111,192.00
01-4196-4523-000	UNEMPLOYMENT INS	909.00	909.00		0.00
01-4196-4524-000	DEDUCTIBLE	2,000.00			2,000.00
Total Department INSURANCE:		169,674.00	56,482.00		113,192.00
MUNICIPAL DUES					
01-4197-4560-000	MEMBERSHIPS	4,043.00	4,043.00		0.00
Total Department MUNICIPAL DUES:		4,043.00	4,043.00		0.00
POLICE					
01-4210-4109-000	WAGES CLERICAL	73,926.00	6,904.80		67,021.20
01-4210-4110-000	WAGES FT	681,634.00	78,888.49		602,745.51
01-4210-4111-000	PART TIME WAGES	40,800.00	5,905.75		34,894.25
01-4210-4112-000	DETAIL WAGES (REVENUE)	4,000.00	2,707.80		1,292.20
01-4210-4120-000	PARKING ENFORCEMENT	1.00			1.00
01-4210-4121-000	CROSSING GUARDS	6,059.00			6,059.00
01-4210-4140-000	WAGES OT	25,000.00	5,507.06		19,492.94
01-4210-4211-000	BENEFIT INSURANCE	215,312.00	29,891.46		185,420.54

BUDGET REPORT FOR TOWN OF HENNIKER

Calculations As of 01/31/2024

GL Number	Description	2024		2024	
		PUBLIC HEARING	FINAL	Activity	PUBLIC HEARING FINAL
Fund: 01 GENERAL FUND					
POLICE					
01-4210-4220-000	FICA/MEDICARE		19,792.00	2,238.29	17,553.71
01-4210-4230-000	RETIREMENT		222,286.00		222,286.00
01-4210-4230-001	RETIREMENT - G1 POLICE DEPT		10,002.00		10,002.00
01-4210-4240-000	TRAINING/LICENSE		5,000.00	1,397.48	3,602.52
01-4210-4241-000	TRAINING/AMMUNITION		4,000.00		4,000.00
01-4210-4291-000	UNIFORMS		8,000.00	102.00	7,898.00
01-4210-4320-000	PROSECUTING ATTN		12,023.00		12,023.00
01-4210-4341-000	TELEPHONE		10,500.00	844.09	9,655.91
01-4210-4342-000	DISPATCH TELEPHONE		1,200.00	105.51	1,094.49
01-4210-4391-000	TOWING		500.00		500.00
01-4210-4392-000	ASSESSMENT CENTER		1,150.00		1,150.00
01-4210-4394-000	MERR COUNTY DISPATCH		54,570.00		54,570.00
01-4210-4410-000	ELECTRICITY		4,886.00	472.92	4,413.08
01-4210-4411-000	HEAT		4,300.00	1,164.47	3,135.53
01-4210-4412-000	WATER/SEWER		900.00	163.80	736.20
01-4210-4430-000	BLDNG REPAIR/MAINT.		4,000.00	804.50	3,195.50
01-4210-4431-000	CUSTODIAN		10,080.00	827.88	9,252.12
01-4210-4550-000	PRINTING		500.00		500.00
01-4210-4560-000	DUES/MEMBERSHIPS		3,500.00		3,500.00
01-4210-4620-000	OFFICE SUPPLIES		4,000.00	370.19	3,629.81
01-4210-4625-000	POSTAGE		600.00		600.00
01-4210-4635-000	VEHICLE FUEL		14,500.00		14,500.00
01-4210-4637-000	BLOOD TEST MILEAGE		1,250.00		1,250.00
01-4210-4660-000	VEHICLE REPAIR/MAINT		7,500.00		7,500.00
01-4210-4661-000	VEHICLE TIRES		2,500.00		2,500.00
01-4210-4662-000	VEHICLE PARTS/ACCESS		2,500.00		2,500.00
01-4210-4670-000	BOOKS/PERIODICALS		350.00		350.00
01-4210-4740-000	EQUIPMENT PURCHASE		1.00		1.00
01-4210-4805-000	EQUIPMENT MAINTENANCE		500.00		500.00
01-4210-4810-000	INFORMATION TECHNOLOGY		27,141.00	3,637.80	23,503.20
01-4210-4814-000	PHOTOCOPY EXPENSE		1,000.00		1,000.00
01-4210-4840-000	COMMUNICATION REPAIR		1,500.00		1,500.00
Total Department POLICE:			1,487,263.00	141,934.29	1,345,328.71
FIRE & RESCUE					
01-4214-4110-000	FULL TIME WAGES		151,191.00	19,987.01	131,203.99
01-4214-4111-000	PART TIME WAGES		382,512.00	50,633.11	331,878.89
01-4214-4140-000	OVER TIME WAGES		20,000.00	4,111.52	15,888.48
01-4214-4211-000	BENEFIT INSURANCE		50,610.00	410.18	50,199.82
01-4214-4220-000	FICA/MEDICARE		31,744.00	4,455.99	27,288.01
01-4214-4230-000	RETIREMENT		51,997.00		51,997.00
01-4214-4341-000	TELEPHONE		10,353.00	624.14	9,728.86
01-4214-4350-000	MEDICAL/HEP B		500.00		500.00
01-4214-4394-000	DISPATCH FEES		48,356.00		48,356.00
01-4214-4410-000	ELECTRICITY		10,500.00	764.63	9,735.37
01-4214-4411-000	HEAT		6,000.00		6,000.00
01-4214-4412-000	WATER		1,600.00	623.73	976.27
01-4214-4430-000	BLDNG MAINTENANCE		12,500.00	(6.80)	12,506.80
01-4214-4610-000	OFFICE SUPPLIES		6,000.00	397.56	5,602.44
01-4214-4690-000	SUPPLIES OTHER		2,800.00	217.90	2,582.10
01-4214-4810-000	INFORMATION TECHNOLOGY		6,840.00	1,140.00	5,700.00
Total Department FIRE & RESCUE:			793,503.00	83,358.97	710,144.03
RESCUE					
01-4215-4110-000	WAGES FULL TIME		20,000.00		20,000.00
01-4215-4115-000	STIPEND		6,500.00	2,775.67	3,724.33
01-4215-4220-000	FICA/MEDICARE		787.00	207.20	579.80
01-4215-4230-000	RETIREMENT		6,070.00		6,070.00
01-4215-4240-000	TRAINING/LICENSE		8,750.00		8,750.00
01-4215-4635-000	VEHICLE FUEL		12,000.00	803.55	11,196.45
01-4215-4660-000	VEHICLE REPAIR/MAINT		14,000.00		14,000.00
01-4215-4680-000	MEDICAL SUPPLIES		12,000.00		12,000.00
01-4215-4740-000	EQUIPMENT PURCHASE		18,400.00		18,400.00
01-4215-4750-000	COMMUNICATION EQUIP		8,490.00		8,490.00
01-4215-4887-000	INTERCEPTOR FEES		2,000.00		2,000.00
01-4215-4888-000	COMSTAR BILLING FEES		20,000.00	654.45	19,345.55
Total Department RESCUE:			128,997.00	4,440.87	124,556.13
FIRE					
01-4220-4111-000	WAGES PT		75,327.00	10,395.73	64,931.27

BUDGET REPORT FOR TOWN OF HENNIKER

Calculations As of 01/31/2024

GL Number	Description	2024		2024	
		PUBLIC HEARING FINAL	Activity	PUBLIC HEARING FINAL	2024 Amt Change
Fund: 01 GENERAL FUND					
FIRE					
01-4220-4220-000	FICA/MEDICARE	5,763.00	795.25		4,967.75
01-4220-4240-000	TRAINING/SEMINARS	6,502.00	100.00		6,402.00
01-4220-4635-000	VEHICLE FUEL	6,810.00	220.10		6,589.90
01-4220-4660-000	VEHICLE REPAIR/MAINT.	20,000.00			20,000.00
01-4220-4690-000	SUPPLIES OTHER	2,125.00			2,125.00
01-4220-4740-000	EQUIPMENT PURCHASES	27,985.00			27,985.00
01-4220-4750-000	COMMUNICATION EQUIPMENT	11,030.00			11,030.00
01-4220-4805-000	EQUIPMENT REPAIR/MAINT.	15,963.00			15,963.00
01-4220-4900-000	CSWW HYDRANT RENTAL	3,950.00			3,950.00
Total Department FIRE:		175,455.00	11,511.08		163,943.92
CODE					
01-4240-4110-000	WAGES	26,417.00	3,398.99		23,018.01
01-4240-4220-000	FICA/MEDICARE	2,021.00	260.03		1,760.97
01-4240-4341-000	TELEPHONE	600.00			600.00
01-4240-4560-000	DUES/MEMBERSHIPS	200.00			200.00
01-4240-4635-000	VEHICLE FUEL/MILEAGE	2,400.00	400.00		2,000.00
01-4240-4670-000	BOOKS/PERIODICAL	600.00			600.00
01-4240-4689-000	SUPPLIES OTHER	150.00			150.00
Total Department CODE:		32,388.00	4,059.02		28,328.98
EMERGENCY MANAGEMENT					
01-4290-4115-000	STIPEND	1,200.00			1,200.00
01-4290-4220-000	FICA	92.00			92.00
01-4290-4341-000	TELEPHONE CHGS	1,200.00			1,200.00
01-4290-4410-000	ELECTRICITY	1,200.00	54.36		1,145.64
01-4290-4411-000	PROPANE	1,151.00			1,151.00
01-4290-4414-000	ALARM MONITOR	500.00			500.00
01-4290-4430-000	BLD REPAIR/MAINT	100.00			100.00
01-4290-4689-000	SUPPLIES OTHER	50.00			50.00
Total Department EMERGENCY MANAGEMENT:		5,493.00	54.36		5,438.64
HIGHWAY					
01-4311-4110-000	WAGES FT	359,944.00	46,804.57		313,139.43
01-4311-4120-000	WAGES PT	25,000.00	5,317.50		19,682.50
01-4311-4140-000	WAGES OT	59,881.00	23,003.32		36,877.68
01-4311-4211-000	BENEFIT INSURANCE	111,876.00	19,310.32		92,565.68
01-4311-4220-000	FICA/MEDICARE	34,029.00	5,592.48		28,436.52
01-4311-4230-000	RETIREMENT	56,802.00			56,802.00
01-4311-4235-000	ADVERTISING	200.00			200.00
01-4311-4240-000	TRAINING/LICENSE	5,000.00			5,000.00
01-4311-4291-000	UNIFORMS	6,000.00	373.70		5,626.30
01-4311-4341-000	TELEPHONE	4,660.00	432.36		4,227.64
01-4311-4350-000	DRUG/ALCOHOL TESTING	3,000.00			3,000.00
01-4311-4410-000	ELECTRICITY	4,200.00	484.67		3,715.33
01-4311-4411-000	HEAT	8,500.00	1,439.44		7,060.56
01-4311-4412-000	WATER/SEWER	3,000.00	565.89		2,434.11
01-4311-4414-000	ALARM	1,500.00	444.00		1,056.00
01-4311-4430-000	BUILDING MAINTENANCE	8,000.00	600.00		7,400.00
01-4311-4560-000	DUES/MEMBERSHIP	50.00			50.00
01-4311-4620-000	OFFICE SUPPLIES	1,200.00	30.99		1,169.01
01-4311-4635-000	FUEL GASOLINE	4,500.00			4,500.00
01-4311-4636-000	FUEL DIESEL	81,000.00	4,064.79		76,935.21
01-4311-4637-000	MILEAGE	4,200.00	680.00		3,520.00
01-4311-4660-000	VEHICLE REPAIR/MAINT	25,000.00	664.33		24,335.67
01-4311-4661-000	VEHICLE TIRES	15,000.00			15,000.00
01-4311-4662-000	VEHICLE PARTS/ACCESS	30,000.00	5,404.97		24,595.03
01-4311-4689-000	SUPPLIES OTHER	1,000.00	4,358.54		(3,358.54)
01-4311-4740-000	EQUIPMENT	4,000.00			4,000.00
01-4311-4805-000	EQUIP MAINT/REPAIR	40,000.00	404.69		39,595.31
01-4311-4810-000	INFORMATION TECHNOLOGY	1,104.00	300.00		804.00
01-4311-4840-000	COMM EQUIP MAINT.	4,000.00	1,556.08		2,443.92
Total Department HIGHWAY:		902,646.00	121,832.64		780,813.36
HIGHWAY & STREETS					
01-4312-4711-000	GRAVEL	26,000.00			26,000.00
01-4312-4712-000	SAND	7,000.00			7,000.00
01-4312-4713-000	SALT	154,000.00	42,754.10		111,245.90
01-4312-4806-000	BRIDGE REPAIR	3,000.00			3,000.00
01-4312-4884-000	ROADSIDE MAINT.	28,000.00			28,000.00

BUDGET REPORT FOR TOWN OF HENNIKER

Calculations As of 01/31/2024

GL Number	Description	2024		2024	
		PUBLIC HEARING	FINAL	Activity	PUBLIC HEARING FINAL
Fund: 01 GENERAL FUND					
HIGHWAY & STREETS					
01-4312-4885-000	ROAD REPAIRS		80,000.00	(3,710.00)	83,710.00
01-4312-4886-000	SIGNS/GUARDRAIL		13,500.00		13,500.00
01-4312-4887-000	STRIPE/SWEEP		14,000.00		14,000.00
01-4312-4888-000	CULVERTS/DRAINS		24,000.00		24,000.00
01-4312-4889-000	TREES		15,000.00	3,500.00	11,500.00
01-4312-4904-000	CHIP SEAL/CRACK SEAL		122,000.00		122,000.00
01-4312-4905-000	ENGINEERING & DESIGN		7,500.00		7,500.00
01-4312-4906-000	ROAD CONSTRUCTION		250,000.00		250,000.00
01-4312-4906-001	ROAD CONSTRUCTION - HBG		130,000.00		130,000.00
Total Department HIGHWAY & STREETS:			874,000.00	42,544.10	831,455.90
STREET LIGHTS					
01-4316-4410-000	ELECTRICITY		13,500.00	337.84	13,162.16
Total Department STREET LIGHTS:			13,500.00	337.84	13,162.16
SOLID WASTE					
01-4324-4110-000	WAGES FT		58,154.00	11,587.63	46,566.37
01-4324-4111-000	PART TIME WAGES		51,287.00	10,438.95	40,848.05
01-4324-4140-000	OT		774.00		774.00
01-4324-4211-000	BENEFIT INSURANCE		10,718.00	1,178.42	9,539.58
01-4324-4220-000	FICA/MEDICARE		8,431.00	1,674.76	6,756.24
01-4324-4230-000	RETIREMENT		7,973.00		7,973.00
01-4324-4240-000	TRAINING/LICENSE		900.00	515.00	385.00
01-4324-4291-000	UNIFORMS		3,000.00	762.48	2,237.52
01-4324-4341-000	TELEPHONE		3,216.00	147.17	3,068.83
01-4324-4355-000	HOUSE HAZ WASTE		25,000.00		25,000.00
01-4324-4410-000	ELECTRICITY		7,500.00	709.63	6,790.37
01-4324-4414-000	ALARM		800.00		800.00
01-4324-4430-000	BLD REPAIR		31,800.00	113.00	31,687.00
01-4324-4560-000	DUES/MEMBERSHIPS		450.00		450.00
01-4324-4570-000	ADVERTISING		200.00		200.00
01-4324-4620-000	OFFICE SUPPLIES		400.00		400.00
01-4324-4635-000	VEHICLE FUEL		5,500.00		5,500.00
01-4324-4637-000	MILEAGE		900.00		900.00
01-4324-4660-000	VEHICLE REPAIR		8,000.00	75.85	7,924.15
01-4324-4688-000	SUPPLIES - STICKERS		2,500.00		2,500.00
01-4324-4689-000	SUPPLIES OTHER		2,500.00		2,500.00
01-4324-4805-000	EQUIP MAINT/REPAIR		18,000.00	45.06	17,954.94
01-4324-4810-000	INFORMATION TECH		2,136.00	356.00	1,780.00
01-4324-4855-000	SAFETY SUPPLIES		1,500.00		1,500.00
01-4324-4901-000	FREON, GLASS, CMPTR		5,000.00		5,000.00
01-4324-4902-000	TRANSPORTATION		22,000.00		22,000.00
01-4324-4903-000	TIPPING FEE		140,000.00		140,000.00
01-4324-4905-000	MONITORING WELLS		17,100.00		17,100.00
01-4324-4906-000	DEMOLITION DISPOSE		43,000.00		43,000.00
Total Department SOLID WASTE:			478,739.00	27,603.95	451,135.05
HEALTH					
01-4411-4115-000	HEALTH OFFICER STIPEND		5,000.00	673.05	4,326.95
01-4411-4220-000	FICA/MEDICARE		383.00	51.46	331.54
01-4411-4689-000	SUPPLIES OTHER		500.00		500.00
Total Department HEALTH:			5,883.00	724.51	5,158.49
ANIMAL CONTROL					
01-4414-4111-000	WAGES		1.00		1.00
01-4414-4115-000	STIPEND		2,080.00		2,080.00
01-4414-4220-000	FICA/MEDICARE		159.00		159.00
01-4414-4240-000	TRAINING		350.00		350.00
01-4414-4291-000	UNIFORMS		150.00		150.00
01-4414-4343-000	ANIMAL RESCUE		700.00	70.00	630.00
01-4414-4637-000	MILEAGE		1,200.00		1,200.00
01-4414-4740-000	EQUIPMENT		100.00		100.00
01-4414-4840-000	RADIO PAGER		600.00		600.00
Total Department ANIMAL CONTROL:			5,340.00	70.00	5,270.00
WELFARE					
01-4442-4111-000	DIRECTOR WAGES PART TIME		13,867.00	1,784.16	12,082.84
01-4442-4220-000	FICA/MEDICARE		1,061.00	136.49	924.51
01-4442-4341-000	TELEPHONE CHGS		1,320.00	103.89	1,216.11
01-4442-4620-000	OFFICE SUPPLIES		200.00		200.00

BUDGET REPORT FOR TOWN OF HENNIKER

Calculations As of 01/31/2024

GL Number	Description	2024		2024	
		PUBLIC HEARING FINAL	Activity	PUBLIC HEARING FINAL	2024 Amt Change
Fund: 01 GENERAL FUND					
WELFARE					
01-4442-4689-000	DIRECTOR EXPENSES	150.00	20.00		130.00
01-4442-4810-000	INFORMATION TECHNOLOGY	1,104.00	184.00		920.00
01-4442-4907-000	GENERAL ASSISTANCE	2,500.00			2,500.00
01-4442-4910-000	ASSIST ELECTRICITY	3,000.00			3,000.00
01-4442-4911-000	ASSIST HEAT	8,000.00			8,000.00
01-4442-4912-000	ASSIST FOOD	2,500.00			2,500.00
01-4442-4913-000	ASSIST RENT	57,000.00	3,682.58		53,317.42
01-4442-4914-000	MEDICAL	1,000.00			1,000.00
Total Department WELFARE:		91,702.00	5,911.12		85,790.88
ATHLETIC					
01-4520-4680-000	MEDICAL FIRST AID SUPPLIES	300.00			300.00
01-4520-4741-000	BASEBALL	9,750.00			9,750.00
01-4520-4742-000	SOCCER	10,050.00	7.50		10,042.50
01-4520-4743-000	BASKETBALL	7,745.00	1,759.85		5,985.15
01-4520-4745-000	SOFTBALL	4,050.00			4,050.00
01-4520-4810-000	TECHNOLOGY WEBSITE	750.00			750.00
Total Department ATHLETIC:		32,645.00	1,767.35		30,877.65
PARKS AND PROPERTY					
01-4530-4110-000	WAGES FT	22,638.00	1,007.95		21,630.05
01-4530-4111-000	WAGES PT	8,470.00	508.13		7,961.87
01-4530-4140-000	OVERTIME	1,548.00			1,548.00
01-4530-4211-000	BENEFIT INSURANCE	3,226.00	367.04		2,858.96
01-4530-4220-000	FICA/MEDICARE	2,498.00	115.51		2,382.49
01-4530-4230-000	RETIREMENT	3,499.00			3,499.00
01-4530-4410-000	ELECTRICITY	720.00	72.82		647.18
01-4530-4412-000	WATER/SEWER	350.00			350.00
01-4530-4430-000	BLD REPAIR/MAINT	500.00			500.00
01-4530-4620-000	SUPPLIES LANDSCAPING	3,500.00			3,500.00
01-4530-4635-000	VEHICLE FUEL	1,000.00			1,000.00
01-4530-4660-000	VEHICLE REPAIRS	1,000.00			1,000.00
01-4530-4688-000	FLOWER PLANTERS	1,000.00			1,000.00
01-4530-4689-000	SUPPLIES OTHER	300.00			300.00
01-4530-4740-000	EQUIPMENT PURCHASE	2,000.00			2,000.00
01-4530-4805-000	EQUIP MAINT/REPAIR	1,000.00			1,000.00
01-4530-4855-000	SAFETY SUPPLIES	500.00			500.00
01-4530-4889-000	TREES	3,000.00			3,000.00
01-4530-4904-000	BEAUTIFICATION PROJECTS	2,500.00			2,500.00
Total Department PARKS AND PROPERTY:		59,249.00	2,071.45		57,177.55
LIBRARY					
01-4550-4110-000	WAGES	192,597.00	23,626.04		168,970.96
01-4550-4211-000	BENEFIT INSURANCE	24,754.00	3,683.34		21,070.66
01-4550-4220-000	FICA/MEDICARE	14,734.00	1,785.25		12,948.75
01-4550-4230-000	RETIREMENT	11,709.00			11,709.00
01-4550-4341-000	TELECOM - INTERNET	2,510.00			2,510.00
01-4550-4410-000	ELECTRICITY	3,200.00			3,200.00
01-4550-4411-000	HEAT	6,154.00			6,154.00
01-4550-4412-000	WATER/SEWER	708.00			708.00
01-4550-4413-000	HEAT FUEL	0.00	865.35		(865.35)
01-4550-4414-000	ALARM MONITOR	408.00			408.00
01-4550-4430-000	BLD REPAIR/MAINT	8,094.00			8,094.00
01-4550-4523-000	WORKERS/UNEMP INS	1,376.00	318.00		1,058.00
Total Department LIBRARY:		266,244.00	30,277.98		235,966.02
PATRIOTIC PURPOSES					
01-4583-4610-000	PATRIOTIC PURPOSES	3,210.00			3,210.00
Total Department PATRIOTIC PURPOSES:		3,210.00	0.00		3,210.00
BAND					
01-4589-4240-000	LICENSES	125.00			125.00
01-4589-4449-000	PORTABLE TOILET RENTAL	3,200.00			3,200.00
01-4589-4570-000	CONCERT ADVERTISING	1,500.00			1,500.00
01-4589-4625-000	POSTAGE	100.00			100.00
01-4589-4689-000	CONCERT SUPPLIES OTHER	500.00			500.00
01-4589-4740-000	EQUIPMENT PURCHASE	1.00			1.00
01-4589-4746-000	CONCERT SERIES PERFORMERS	15,400.00			15,400.00
01-4589-4810-000	CONCERT MUSIC LICENSES	900.00			900.00
Total Department BAND:		21,726.00	0.00		21,726.00

BUDGET REPORT FOR TOWN OF HENNIKER
Calculations As of 01/31/2024

GL Number	Description	2024		2024	
		PUBLIC HEARING	FINAL	Activity	PUBLIC HEARING FINAL
Fund: 01 GENERAL FUND					
CONSERVATION					
01-4611-4112-000	MINUTE TAKER		484.00	84.46	399.54
01-4611-4220-000	FICA/MEDICARE		37.00	6.46	30.54
01-4611-4240-000	TRAINING		420.00		420.00
01-4611-4560-000	DUES/MEMBERSHIP		345.00		345.00
01-4611-4620-000	OFFICE SUPPLIES		25.00		25.00
01-4611-4951-000	PUBLIC AWARENESS		235.00		235.00
01-4611-4952-000	LAKE MONITOR		1,400.00		1,400.00
	Total Department CONSERVATION:		<u>2,946.00</u>	<u>90.92</u>	<u>2,855.08</u>
COMMUNITY CAP PROGRAM					
01-4652-4610-000	COMMUNITY CAP PROGRAM		14,000.00		14,000.00
	Total Department COMMUNITY CAP PROGRAM:		<u>14,000.00</u>	<u>0.00</u>	<u>14,000.00</u>
WHITE BIRCH CENTER					
01-4659-4612-000	WHITE BIRCH CENTER		65,000.00		65,000.00
	Total Department WHITE BIRCH CENTER:		<u>65,000.00</u>	<u>0.00</u>	<u>65,000.00</u>
DEBT SERVICE PRINCIPAL					
01-4711-4940-000	PRINCIPAL		92,596.00		92,596.00
	Total Department DEBT SERVICE PRINCIPAL:		<u>92,596.00</u>	<u>0.00</u>	<u>92,596.00</u>
DEBT SERVICE INTEREST					
01-4721-4940-000	INTEREST		16,265.00	656.25	15,608.75
	Total Department DEBT SERVICE INTEREST:		<u>16,265.00</u>	<u>656.25</u>	<u>15,608.75</u>
DEBT SERVICE LEASE					
01-4722-4800-000	DEBT SERVICE LEASE		37,568.00		37,568.00
	Total Department DEBT SERVICE LEASE:		<u>37,568.00</u>	<u>0.00</u>	<u>37,568.00</u>
DEBT SERVICE TAN					
01-4723-4940-000	TAN INTEREST		13,500.00		13,500.00
	Total Department DEBT SERVICE TAN:		<u>13,500.00</u>	<u>0.00</u>	<u>13,500.00</u>
WARRANT ARTICLES					
01-4903-4039-000	FIRE-RESCUE BUILDING ETF		0.00	19,482.00	(19,482.00)
	Total Department WARRANT ARTICLES:		<u>0.00</u>	<u>19,482.00</u>	<u>(19,482.00)</u>
Fund 01 - GENERAL FUND:					
	TOTAL APPROPRIATIONS		<u>6,926,886.00</u>	<u>669,882.01</u>	<u>6,257,003.99</u>

BUDGET REPORT FOR TOWN OF HENNIKER

Calculations As of 01/31/2024

GL Number	Description	2024	
		PUBLIC HEARING FINAL	Activity
		2024	
		PUBLIC HEARING FINAL	FINAL Amt Change
Fund: 01 GENERAL FUND			
4902	WARRANT ARTICLES	270,000.00	270,000.00
4903	WARRANT ARTICLES	100,000.00	80,518.00
4915	CAPITAL RESERVE	1,315,000.00	1,315,000.00
Fund 01 - GENERAL FUND:			
TOTAL APPROPRIATIONS		1,685,000.00	1,665,518.00

BUDGET REPORT FOR TOWN OF HENNIKER
Calculations As of 01/31/2024

GL Number	Description	2024	2024	2024
		PUBLIC HEARING FINAL	Activity	PUBLIC HEARING FINAL Amt Change
Fund: 01 GENERAL FUND				
4130	EXECUTIVE	355,201.00	40,976.14	314,224.86
4140	TOWN CLERK	107,782.00	12,509.87	95,272.13
4141	ELECTIONS	29,986.00	2,894.06	27,091.94
4142	TAX MAP	4,950.00	575.00	4,375.00
4150	FINANCE	245,518.00	22,944.33	222,573.67
4151	TAX COLLECTOR	114,689.00	12,419.05	102,269.95
4152	ASSESSING	55,400.00		55,400.00
4153	LEGAL	40,000.00	45.00	39,955.00
4191	PLANNING	31,726.00	10,201.22	21,524.78
4192	ZONING	5,271.00	318.75	4,952.25
4194	GENERAL GOVERNMENT BUILDINGS	107,758.00	7,744.89	100,013.11
4195	CEMETERIES	35,030.00		35,030.00
4196	INSURANCE	169,674.00	56,482.00	113,192.00
4197	MUNICIPAL DUES	4,043.00	4,043.00	0.00
4210	POLICE	1,487,263.00	141,934.29	1,345,328.71
4214	FIRE & RESCUE	793,503.00	83,358.97	710,144.03
4215	RESCUE	128,997.00	4,440.87	124,556.13
4220	FIRE	175,455.00	11,511.08	163,943.92
4240	CODE	32,388.00	4,059.02	28,328.98
4290	EMERGENCY MANAGEMENT	5,493.00	54.36	5,438.64
4311	HIGHWAY	902,646.00	121,832.64	780,813.36
4312	HIGHWAY & STREETS	874,000.00	42,544.10	831,455.90
4316	STREET LIGHTS	13,500.00	337.84	13,162.16
4324	SOLID WASTE	478,739.00	27,603.95	451,135.05
4411	HEALTH	5,883.00	724.51	5,158.49
4414	ANIMAL CONTROL	5,340.00	70.00	5,270.00
4442	WELFARE	91,702.00	5,911.12	85,790.88
4520	ATHLETIC	32,645.00	1,767.35	30,877.65
4530	PARKS AND PROPERTY	59,249.00	2,071.45	57,177.55
4550	LIBRARY	266,244.00	30,277.98	235,966.02
4583	PATRIOTIC PURPOSES	3,210.00		3,210.00
4589	BAND	21,726.00		21,726.00
4611	CONSERVATION	2,946.00	90.92	2,855.08
4652	COMMUNITY CAP PROGRAM	14,000.00		14,000.00
4659	WHITE BIRCH CENTER	65,000.00		65,000.00
4711	DEBT SERVICE PRINCIPAL	92,596.00		92,596.00
4721	DEBT SERVICE INTEREST	16,265.00	656.25	15,608.75
4722	DEBT SERVICE LEASE	37,568.00		37,568.00
4723	DEBT SERVICE TAN	13,500.00		13,500.00
Fund 01 - GENERAL FUND:				
TOTAL APPROPRIATIONS		6,926,886.00	650,400.01	6,276,485.99

BUDGET REPORT FOR TOWN OF HENNIKER
Calculations As of 01/31/2024

GL Number	Description	2024	2024	2024
		PUBLIC HEARING FINAL	Activity	PUBLIC HEARING FINAL Amt Change
Fund: 03 WASTEWATER TREATMENT PLANT				
03-4326-4110-000	WAGES FT	189,744.00	23,990.41	165,753.59
03-4326-4130-000	COMM/TREAS/ACCTNG	2,435.00		2,435.00
03-4326-4140-000	WAGES OT	7,729.00	1,064.25	6,664.75
03-4326-4211-000	BENEFIT INSURANCE	68,581.00	10,564.64	58,016.36
03-4326-4220-000	FICA/MEDICARE	15,293.00	1,856.94	13,436.06
03-4326-4230-000	RETIREMENT	26,718.00		26,718.00
03-4326-4240-000	TRAINING/LICENSE	1,200.00		1,200.00
03-4326-4291-000	UNIFORMS	1,071.00		1,071.00
03-4326-4301-000	ACCOUNTING	1,050.00		1,050.00
03-4326-4320-000	LEGAL FEES/CONSULTING	20,000.00		20,000.00
03-4326-4341-000	TELEPHONE	4,000.00	245.67	3,754.33
03-4326-4408-000	ELECTRICITY PUMP STATION	4,500.00	651.54	3,848.46
03-4326-4409-000	ELECTRICITY	52,000.00	6,473.99	45,526.01
03-4326-4410-000	ELEC MAPLE STREET	1,510.00	272.95	1,237.05
03-4326-4411-000	HEAT BELT PRESS BLDING	7,000.00	451.99	6,548.01
03-4326-4412-000	WATER	27,500.00	11,901.85	15,598.15
03-4326-4413-000	HEAT PLANT	10,557.00	779.53	9,777.47
03-4326-4414-000	ALARM SERVICE	850.00		850.00
03-4326-4415-000	PROPANE	2,000.00	148.38	1,851.62
03-4326-4430-000	BUILDING REPAIR/MAINT	2,040.00		2,040.00
03-4326-4520-000	WORKERS COMP INSURANCE	2,915.00	2,915.00	0.00
03-4326-4521-000	GENERAL LIAB INS.	12,423.00	100.00	12,323.00
03-4326-4550-000	PRINTING	700.00		700.00
03-4326-4560-000	DUES/MEMBERSHIPS	763.00		763.00
03-4326-4620-000	OFFICE SUPPLIES	885.00		885.00
03-4326-4625-000	POSTAGE	700.00		700.00
03-4326-4635-000	VEHICLE FUEL	1,300.00		1,300.00
03-4326-4650-000	LAWN TRACTOR REPAIR	600.00		600.00
03-4326-4660-000	VEHICLE REPAIR	1,000.00		1,000.00
03-4326-4662-000	VEHICLE PARTS/ACCESSORIES	2,200.00		2,200.00
03-4326-4689-000	SUPPLIES OTHER	2,780.00		2,780.00
03-4326-4741-000	TOOL PURCHASES	1,680.00		1,680.00
03-4326-4805-000	EQUIPMENT REPAIR/MAINT.	39,830.00		39,830.00
03-4326-4810-000	COMPUTER REPAIR/MAINT.	3,310.00	300.00	3,010.00
03-4326-4855-000	SAFETY SUPPLIES	2,886.00	379.46	2,506.54
03-4326-4860-000	LAB REPAIR/MAINTENANCE	4,055.00		4,055.00
03-4326-4862-000	IN HOUSE LAB	9,400.00		9,400.00
03-4326-4864-000	OUTSIDE LAB	9,500.00	177.00	9,323.00
03-4326-4869-000	SLUDGE PROCESSING	11,167.00		11,167.00
03-4326-4870-000	SLUDGE DISPOSAL EXPENSE	59,180.00	1,994.54	57,185.46
03-4326-4871-000	GRIT DISPOSAL	2,700.00		2,700.00
03-4326-4875-000	COLLECTION SYSTEM	28,864.00		28,864.00
03-4326-4940-000	DEBT SERVICE	36,920.00		36,920.00
03-4326-4988-000	PH ADJUSTMENT	49,256.00	4,107.00	45,149.00
03-4326-4990-000	EMERGENCY EXPENDITURES	50,000.00		50,000.00
Fund 03 - WASTEWATER TREATMENT PLANT:				
TOTAL APPROPRIATIONS		780,792.00	68,375.14	712,416.86



The month of January 2024 consisted of 23 calls for Henniker Fire Department. The calls ranged from the following:

- 3 Fire Alarm Activations
- 2 EMS Assists
- 2 Motor Vehicle Accidents
- 1 Animal Rescue
- 1 Chimney Fire
- 3 Building Fires
- 6 Tree's/ Wires
- 2 Co calls
- 3 Smoke in buildings

This month's trainings consisted of CPR training, Dam tour of Hopkinton Everett

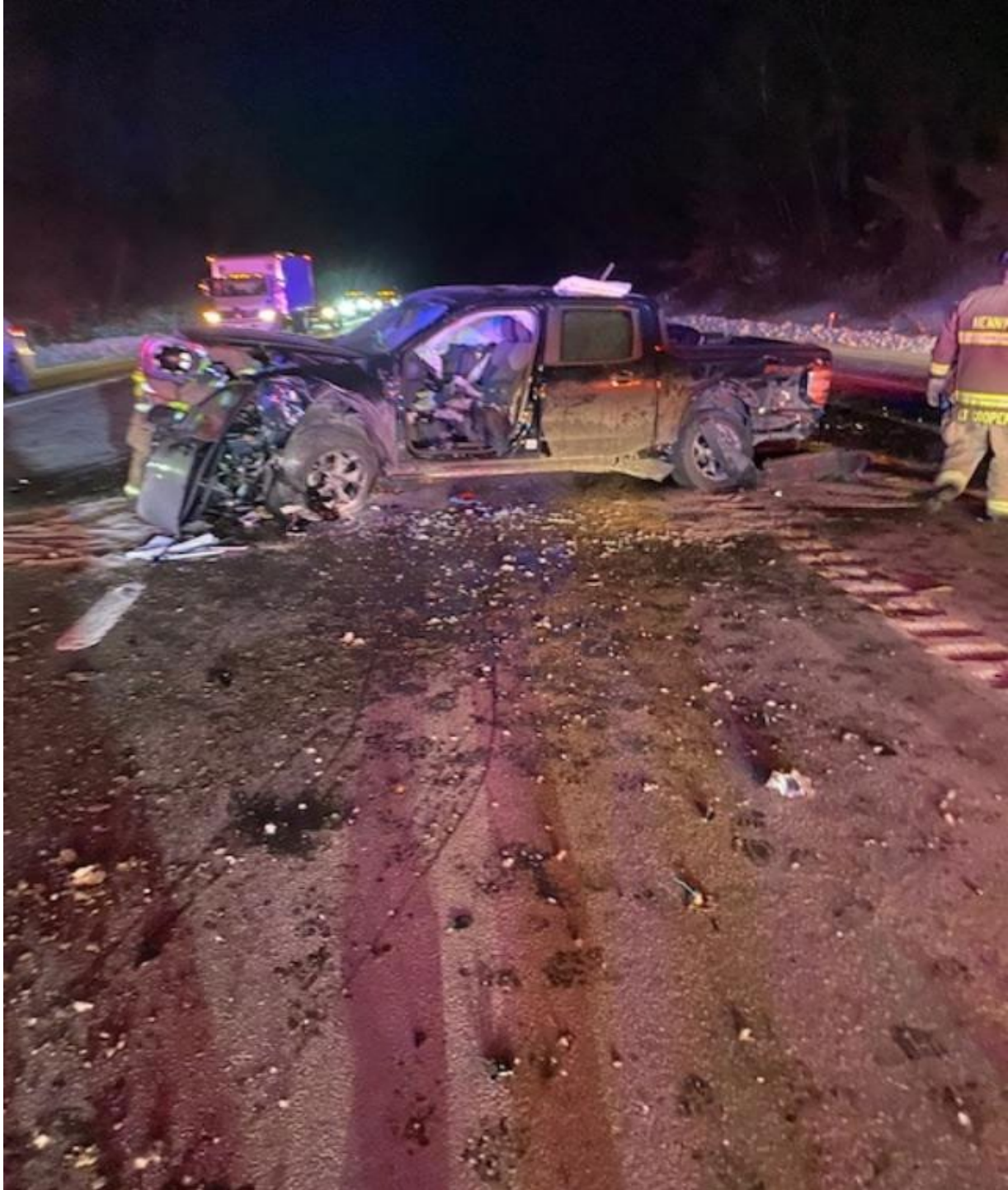

Thank you,
Chief Morse

2/16/2024

To Town Administrator Diane Kendall and Henniker Board of Selectmen:

Henniker Highway Department started the month of January completing the final dirt work project of the 2023 season, placing gravel on a road widening project on Line Hill Road, and expanding the ditch line on a short section of French Road. As the Highway Department worked on those projects, Sam Harris of NH Arbor Works removed several trees on French Road, Lone Pine Road, Huntington Road, and Butter Road for the Department. The first snow event of the year fell on the 7th, nearly 10 inches. Throughout the month the Superintendent worked closely with contractors on the Tower Project, making sure the road was plowed and sanded. Truck and equipment service was in the daily operation of the department, changing cutting edges and oil changes. In late January we had a week from hell with constant freezing drizzle. On the 28th we closed out the month with another snowstorm.

Leo Aucoin
Superintendent
Henniker Highway

MEMORANDUM

To: Diane Kendall, Town Administrator
From: Jean Scott – Deputy Town Clerk/Tax Collector
Date: February 1,2024
Subject: Town Clerk/Tax Collector Report as of 01/31/2024

PROPERTY TAXES

Total Committed 2023	\$16,418,383.26
Uncollected	\$554,700.05

TAX LIENS

	<u>2022 LIENS</u>	<u>2021 LIENS</u>	<u>2020/PRIOR LIENS</u>
Liened Amount	\$177,560.95	\$208,703.03	
Uncollected	\$110,222.48	\$67,207.67	\$159,306.05

WATER & SEWER -

	<u>2023</u>	<u>2024</u>
Water Billed	\$550,267.04	\$254,921.10
Sewer Billed	\$562,919.64	\$
Uncollected	\$81,233.47	\$235,541.30

TOWN CLERK REVENUE

	<u>2024</u>	<u>2023</u>	<u>2022</u>
MV	\$70,889.99	\$72,886.60	\$133,873.82
non-MV	\$526.93	\$226.50	\$ 1,372.16

Marc Boisvert

Transfer Station Superintendent
1393 Weare Rd.
Henniker. NH.
(603)428-7604
<http://www.henniker.org/>
transfer@hennikernh.org

Monthly Report – January 2024

1/2/24. Cut dead branches on the trees around Town Hall. Had a hydraulic line leak on the backhoe. The backhoe went to Highway Garage to be repaired.

1/3/24. We borrowed the highway loader and an operator to continue cutting dead branches in the area of Town Hall. Had Ben come in to help.

1/4/24. Did the morning dump run. We cleaned an area for small amount of salt storage, and we picked up salt from the Highway Garage. The glass container was full, so we called to have it picked up. Opened for usual business.

1/6/24. Matt worked for Marc. Opened for business as usual.

1/7/24. Went around town shoveling and treating all the usual areas, kept them clear throughout the day, we opened for business.

1/8/24. Matt and Ben came in to clean up around town after the storm. They also cleaned the Transfer Station in preparation for glass pickup on Tuesday.

1/9/24. Went out and checked around town buildings for icy spots. Did a complete grease maintenance on the backhoe. Matt installed two new signs above the hopper doors, also went to Town Hall and shoveled pathway to access bulkhead for oil delivery and maintenance.

We were expecting a glass pick up early in the afternoon. Unfortunately, there was a snowstorm in Canada that delayed our pick-up time. We kept in constant contact with the Highway Dept. on the delays due to the incoming storm. We did get the glass loaded and loader back around 5:30 PM.

1/10/24. Shoveled and treated walkways around town. Cleaned around the Transfer Station and cleaned out aluminum can bin.

1/11/24. Did the dump run, cleaned around the shop and the yard. Went to the food pantry to look at the area needing to be repaired. We opened for business.

1/13/24. Did the dump run. Prepped the Community Center for rental for baby shower. Repaired the area at the food pantry. We opened for business. Also added hydraulic fluid to cardboard.

12/14/24. Opened for business as usual. Set up table at Community Center for Energy Committee meeting.

12/15/24. Ben and Matt came in and cleaned and treated walkways around town.

1/16/24. Set up chairs for the B.O.S meeting. Looking into the electrical outlet problem at Community Center, found that two breakers have tripped, sub panel is downstairs in the closet. Worked on clearing ice and snow at the Transfer Station.

1/17/24. Cleared snow and treated downtown walkways. Cleaned Transfer Station yard and pushed back snowbanks. Worked on repairing parks equipment for next spring. Ben came in 7-11 to help out.

1/18/24. A balloon was removed from the ceiling fan at the Community Center. The string was wrapped around the motor. This item was part of the baby shower rental. We did the dump run. Put screws in doorbell bracket on back door at Town Hall, per request.

1/20/24. Cleaned out the Community Center closet so all the electrical equipment can be installed professionally and clean. We also checked Town Hall for frozen pipes. We kept the water trickling in the kitchen faucet to help stop freezing. We checked trash barrels around town and then opened for business.

1/21/24. Opened for business.

1/22/24. Matt, Zach, and Ben met with the school crew at the middle school gym to set up voting area for primary.

1/23/24. The water bill at the grange showed excessive water usage. The Town Administrator had us look into potential problem. We had the Water Dept. check the water meter. The meter was showing a water leak. After searching we found the toilet was the problem. We put some new parts in the toilet, it continued to leak. We needed to have a plumber do a complete rebuild on it. We opened for business as usual. Matt, Zach, and Ben met the school crew at the middle school to tear down voting area after primary.

10/24/24. Cleaned and treated walkways and steps downtown after snowstorm. Worked on cleaning the transfer station yard.

1/25/24. I met with the plumber at the Grange after he rebuilt the toilet. We salted all the slippery spots in town. We also had the fire extinguisher company do their yearly inspections.

1/26/24. Matt came in checking all the town buildings for icy spots.

1/27/24. Treated all the icy spots around the town buildings, Highway Department came through the Transfer Station dropping salt for us. We opened for business.

1/28/24. Opened for business. Found power cable on plow failed while preparing for upcoming storm.

1/29/24. Town plow truck was down due to a broken wire harness. I came in and plowed the yard, also had Zach and Ben shovel, and treated all the walkways in front of the town buildings. Crushed aluminum cans.

1/30/24. Checked all areas for icy spots, opened for business. Installed new plow cable on pick-up truck. Plow side cable broke while working on it.

1/31/24. Picked up new plow side power cable and installed it. Did not completely solve the issue. Worked on electrical system. Crushed aluminum cans.

Wastewater Treatment Plant Monthly Report

January 2024

During the month of January at the treatment plant we experienced challenges with the belt press that the team worked on to overcome. Some of those challenges were realigning the belts, taking apart, and rebuilding the sludge pump for the belt press. We also had a state inspection of the plant and listened to some of the things they would like to see around the plant that were minor changes. We are collaborating as a team for solutions such as containing the barrels of caustic located inside the grit room. Throughout the month we also did snow removal, all daily labs and state labs.

Respectfully submitted,

Richard Slager

Superintendent

Wastewater Treatment Plant

NONPUBLIC #2